

MAINTENANCE and OVERHAUL MANUAL

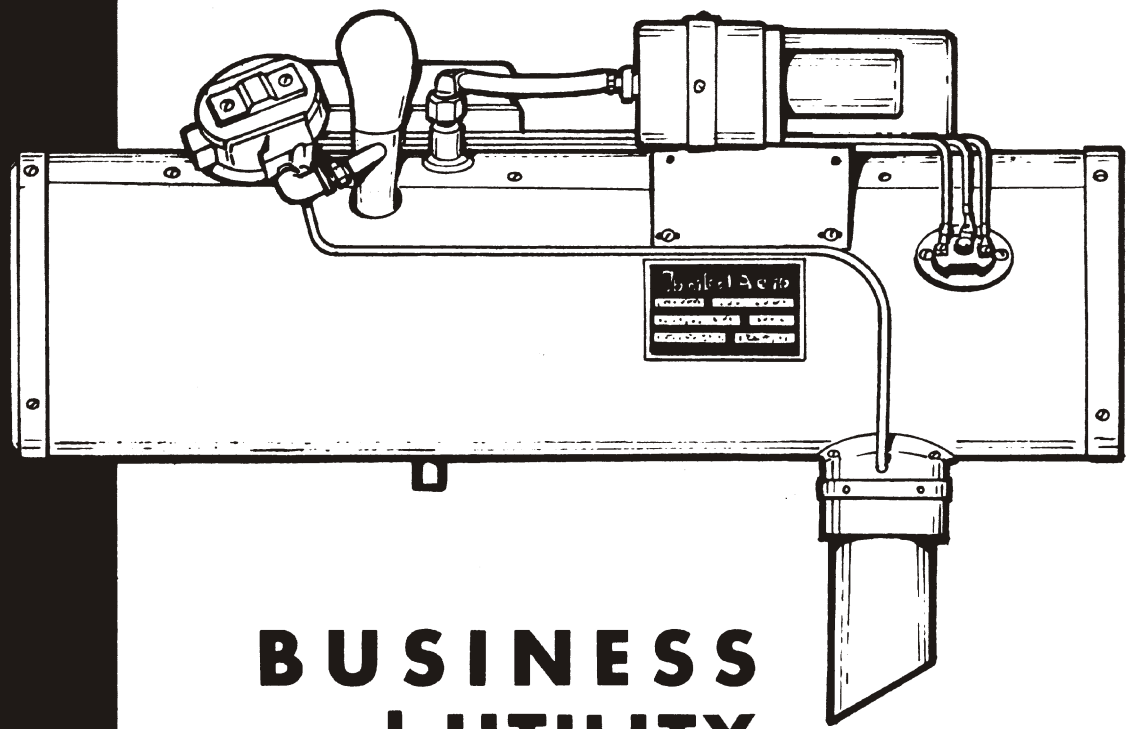

BUSINESS and UTILITY AIRCRAFT HEATERS



*AeroGraphics
1725 N. Lexington Ave.
DeLand, FL USA 32724*

JANITROL AERO DIVISION

MIDLAND-ROSS CORPORATION • COLUMBUS, OHIO
INSTRUCTION PART NO. 24E25-1 OCT. 1981

28-11-10-07-02-00 Sch Del 10/06/03

P/N 60-24E25-1
1 EA Pkg Qty 00001

001
Line Number
3
No. of Picks

MAINTENANCE/OVERHAUL MANUAL

CONT: 7083279

Ship No. 001854276



Haz #

TOTE P315N215 OE RG
UPS

FAA Approval

LOT # AV0603561350



CPO MIKE



PNR 24E25-1



SHQ 1



UNT EA



10/6/03 15:34

TABLE OF CONTENTS

| Section | | Page |
|---------|--|------|
| I | INTRODUCTION | 1 |
| II | DESCRIPTION AND OPERATION | 3 |
| | 2.1 Description of Heater and Basic Components | 3 |
| | 2.2 Operating Controls | 6 |
| | 2.3 Operating Procedure | 7 |
| III | MAINTENANCE SERVICE | 8 |
| | 3.1 Preflight and/or Daily Inspection | 8 |
| | 3.2 Operational Check | 8 |
| | 3.3 100-Hour Inspection and Pressure Decay Test | 8 |
| | 3.4 Trouble-Shooting | 14 |
| | 3.5 Electrical Continuity Check | 14 |
| | 3.6 General Maintenance | 18 |
| | 3.7 Combustion Air Blower | 18 |
| | 3.8 Spark Plug | 20 |
| | 3.9 Vibrator Assembly | 23 |
| | 3.10 Ignition Assembly | 24 |
| | 3.11 Fuel Pump | 24 |
| | 3.12 Cycling Switch and Limit (Overheat) Switch | 24 |
| | 3.13 Combustion Air Pressure Switch | 25 |
| | 3.14 Fuel Regulator and Shutoff Valve | 25 |
| | 3.15 Duct Switch | 25 |
| IV | OVERHAUL INSTRUCTIONS | 26 |
| | 4.1 Disassembly | 26 |
| | 4.2 Disassembly of Combustion Air Blower Assembly | 27 |
| | 4.3 Disassembly of Fuel Pump | 27 |
| | 4.4 Cleaning Procedures | 27 |
| | 4.5 Cleaning Fuel Pump Parts | 28 |
| | 4.6 Cleaning and Inspecting the Combustion Tube Assembly | 28 |
| | 4.7 Inspection of Remaining Components | 29 |
| | 4.8 Inspection of Fuel Pump Parts | 30 |
| | 4.9 Testing | 30 |
| | 4.10 Repair of Combustion Tube Assembly | 31 |
| | 4.11 Reassembly | 31 |
| | 4.12 Reassembly of Combustion Air Blower Assembly | 33 |
| | 4.13 Reassembly of Fuel Pump | 33 |
| V | TEST PROCEDURE | 34 |
| | 5.1 General Information | 34 |
| | 5.2 Test Procedure | 34 |
| | 5.3 Equipment Required | 34 |
| | 5.4 Operational Test | 34 |
| VI | ILLUSTRATED PARTS BREAKDOWN | 37 |
| | LIST OF TABLES | |
| | Heater Models | 2 |
| | Troubleshooting | 15 |

LIST OF ILLUSTRATIONS

| Figure | Page |
|---|------|
| 2-1 Diagramatic Cutaway of Heater to Show Whirling Flame Action - - - - - | 3 |
| 2-2 The Electric Fuel Pump - - - - - | 4 |
| 2-3 Electric Fuel Pumps used with Aviation Kerosene Fuel Applications - - - - - | 4 |
| 2-4 The Pressure Relief Valve - - - - - | 4 |
| 2-5 The Fuel Regulator and Shut-Off Valve - - - - - | 4 |
| 2-6-1 Duct Switch Assembly - - - - - | 5 |
| 2-6-2 Top View of Duct Switch Showing Control Lever Positions - - - - - | 5 |
| 2-7 Vent Air Blower Assembly - - - - - | 5 |
| 2-8-1 The Combustion Air Blower Assembly - - - - - | 5 |
| 2-8-2 Combustion Air Blower - - - - - | 6 |
| 2-8-3 Combustion Air Blower and Regulator Assembly - - - - - | 6 |
| 2-9 Wiring Diagram (Typical) - - - - - | 7 |
| 3-1 Test Set-Up Pressure Decay Inspection Test - - - - - | 9 |
| 3-2 Combustion Tube Pressure Decay Test Parts Kit (Part No. 26E24-1) - - - - - | 10 |
| 3-3 Combustion Air Tube - Pressure Supply Assembly Installed - - - - - | 11 |
| 3-4 Exhaust Tube Seal - Shown Installed Just Prior to Inflation - - - - - | 12 |
| 3-5 Test Set-Up Pressure Decay Inspection Test (same as 3-1) - - - - - | 13 |
| 3-6 Primary Power Circuit (Typical) - - - - - | 18 |
| 3-7 Starting Power Circuit (Typical) - - - - - | 19 |
| 3-8 Running Power Circuit (Typical) - - - - - | 20 |
| 3-9 Type I Spark Plug - - - - - | 21 |
| 3-10 Type II Spark Plug - - - - - | 22 |
| 3-11 Special Ground Electrode Fixture - - - - - | 23 |
| 3-12 Type III Spark Plug - - - - - | 23 |
| 4-1 Exploded View of Electric Fuel Pump - - - - - | 28 |
| 4-2 Suggested Design for Seal Plate, Plugs and Caps for Combustion Tube Leakage Test - - - - - | 30 |
| 4-3 Test Set-Up for Combustion Air Pressure Switch - - - - - | 30 |
| 5-1 Suggested Set-Up for Heater Operation Test - - - - - | 35 |
| 5-2 Wiring Connections for Heater Operation Test (Typical) - - - - - | 35 |
| 6-1 Exploded View of Business Aircraft Heater Assembly Non-Pressurized - - - - - | 37 |
| 6-2 Typical Pressurized Heater - - - - - | 39 |
| 6-3 Vent Air Blower Assembly - - - - - | 41 |
| 6-4 Exploded View of Combustion Air Blower and Motor Assembly - - - - - | 42 |
| 6-5 Combustion Air Blower Assembly - - - - - | 43 |
| 6-6 Exploded View of Adjustable Duct Switch Assembly - - - - - | 44 |
| 6-7 Electric Fuel Pump - - - - - | 44 |

SECTION I - INTRODUCTION

This manual is designed to provide operation, service and overhaul instructions, with a parts illustration for Janitrol* Business and Utility Aircraft Heaters. Heater capacities range from 15,000 to 50,000 BTU/Hr in four sizes as shown in the Table 1. All models are available with both 12-volt and 24-volt DC electrical components. This equipment is designed and manufactured by Janitrol Aero Division, Midland-Ross Corporation, Columbus, Ohio 43228. These models are FAA-TSO-C20 approved.

Installation details are determined by the aircraft manufacturer and will vary in some respects from one make or model of aircraft to another**. When installing a Janitrol heater in existing aircraft refer to the Manual of Installation Instructions, Part No. 11D73.

All heaters are similar in design. They differ only in size and output capacity. The Model B1500 is smaller in dia-

meter but remaining models have the same diameter and differ only in length for increased capacity. Both gasoline and kerosene burning models are available.

Each heater system consists of a heater assembly, a ventilating air blower, a combustion air blower, nozzle holder, solenoid valve assembly, spark plug, high-voltage ignition system, combustion air pressure switch, overheat switch, cycling switch, and necessary radio-noise suppressors. Optional equipment includes a duct switch, fuel pump, fuel regulator and shutoff valve, combustion air blower inlet adapter and a fanning strip (electrical connectors). All components except the combustion air blower, duct switch, fuel regulator and shutoff valve and fuel pump are combined into one assembly to facilitate installation and service operations. The optional equipment items are provided as separate components since they may be mounted at different locations in the aircraft.

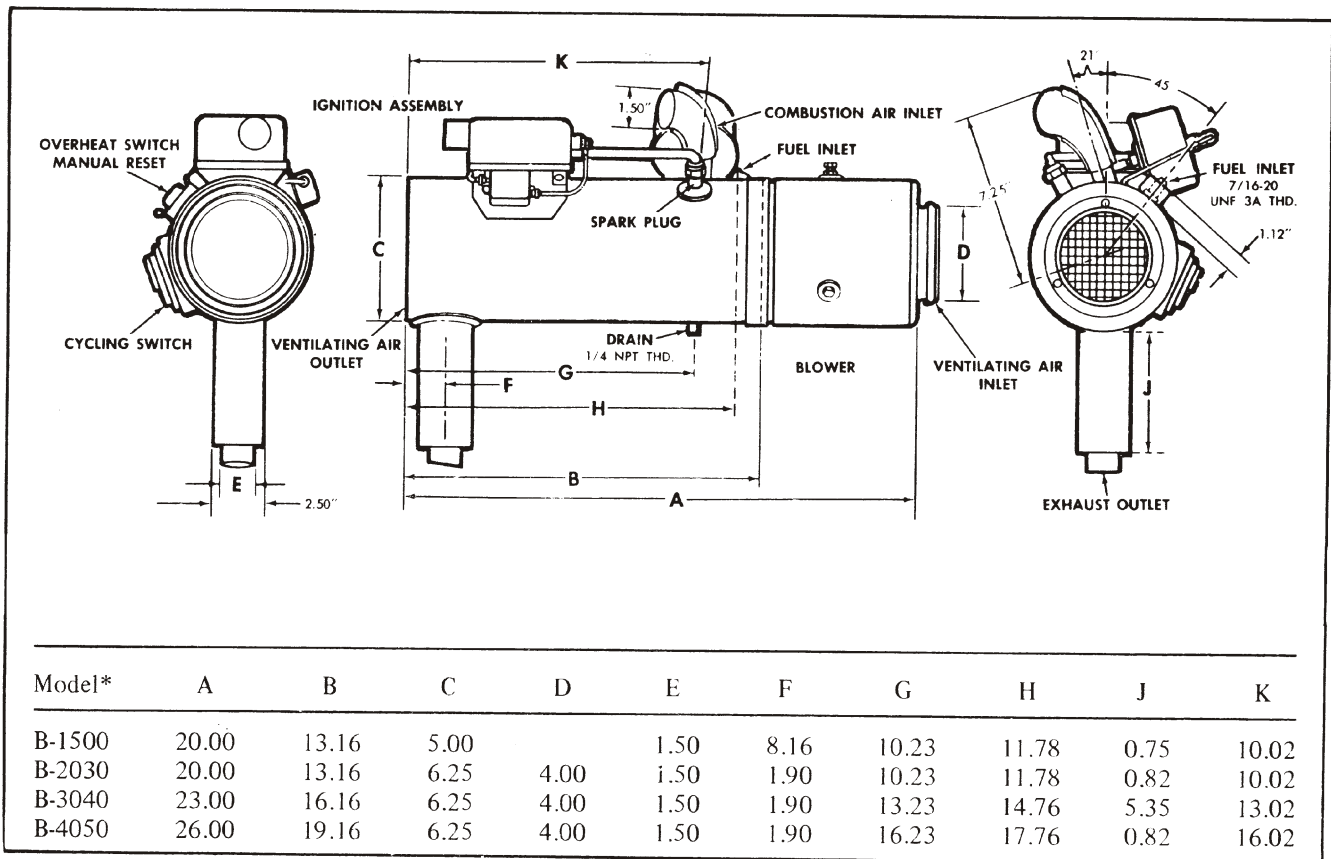

* This is basic information. Many heaters will have varying dimensions and configurations for specific aircraft installation.

** Service manuals are produced by airframe manufacturers for each different aircraft model with service and maintenance sections covering combustion heaters. These aircraft manuals are to be used rather than this manual.

TABLE 1 SHOWN BELOW LISTS THE HEATER ASSEMBLIES FOR EACH MODEL SERIES.

| <u>MODEL B1500 HEATERS</u> | | |
|---|-----------------|-----------------|
| <u>Part No.</u> | <u>Part No.</u> | |
| 96C60 | 99C42 | |
| <u>MODEL B2030 HEATERS</u> | | |
| <u>Part No.</u> | <u>Part No.</u> | <u>Part No.</u> |
| 96C92 | 22D01 | 82D31-1 |
| 15D23 | 37D88 * | 82D31-2 |
| 15D83 | A37D88 * | |
| 15D94 | B37D88 * | |
| 20D35 | 42D79 | |
| 20D35-1 | 56D03 | |
| 21D66 | 74D01-1 | |
| | 74D01-2 | |
| | 74D01-3 | |
| * indicates kerosene fuel burning heater assemblies | | |
| <u>MODEL B3040 HEATERS</u> | | |
| <u>Part No.</u> | <u>Part No.</u> | <u>Part No.</u> |
| 96C62 | A39D59 | 62D95-1 |
| 96C62-1 | B39D59 | 63D98 |
| 15D31 | C39D59 | 63D98-1 |
| 15D96 | D39D59 | 82D20-1 |
| 22D25 | 39D84 | 82D20-2 |
| 22D25-1 | 41D95 | 88D81-1 * |
| 32D99 | 45D70 | 88D81-2 * |
| 34D35 | 45D70-1 | 88D81-3 * |
| A34D35 | 45D70-2 | 90D38-1 |
| 34D51 | 47D65 | 90D38-2 |
| A34D51 | 47D65-1 | 96D75-1 |
| B34D51 | 47D65-3 | 04D34-1 * |
| C34D51 | 56D86 | 04D34-2 * |
| D34D51 | 62D33 * | 10E21-1 * |
| 37D77 | 62D33-1 * | 10E21-2 * |
| 37D77-1 | 62D33-2 * | 10E21-3 * |
| 39D59 | 62D95 | 10E21-4 * |
| | | 11E82-1 |
| * indicates kerosene fuel burning heater assemblies | | |
| <u>MODEL B4050 HEATERS</u> | | |
| <u>Part No.</u> | <u>Part No.</u> | <u>Part No.</u> |
| 99C80 | 65D79-2 | 07E94-1 |
| 99C80-1 | 65D79-3 | 07E94-2 |
| 15D48 | 81D94-1 | 08D36-1 |
| 15D87 | 81D94-2 | 09D21-1 |
| 15D98 | 81D94-3 | 13E55-1 |
| 39D90 * | 82D01-1 | 13E55-2 |
| 39D90-1 * | 02E17-1 | 19E69-1 |
| 65D79 | 02E17-2 | 23E63-1 * |
| 65D79-1 | 07E02-1 | 24E07-1 * |
| * indicates kerosene fuel burning heater assemblies | | |

SECTION II - DESCRIPTION AND OPERATION

2.1 Description of Heater and Basic Components

Janitrol Business and Utility Aircraft Heaters embody the same proven reliability as Janitrol heaters, used in the majority of Commercial, Military, and Private transport aircraft for over 38 years.

A few of the outstanding features on these heaters are as follows:

Spark-Spray Ignition

The controlled atomized spray from a specially designed spray nozzle, coupled with high-voltage spark plug ignition, insures instant firing and continuous burning under all flight conditions. Spark-spray ignition combined with the exclusive Janitrol whirling-flame combustion has been proved by million of hours of heater operation in all types of aircraft throughout the world.

Heat is produced by burning a fuel-air mixture in the combustion chamber of the heater. Aviation fuel is injected into the combustion chamber through the spray nozzle. The resulting cone-shaped fuel spray mixes with combustion air and is ignited by a spark from the spark plug. Electric current for ignition is supplied by an ignition unit which converts 12 volts or 24 volts to high-voltage, oscillating current to provide a continuous spark across the spark gap. A shielded, high voltage lead connects the ignition assembly to the spark plug. Combustion air enters the combustion chamber tangent to its surface and imparts a whirling or spinning action to the air. This produces a whirling flame that is stable and sustains combustion under the most adverse conditions because it is whirled around

itself many times. Therefore, ignition is continuous and the combustion process is self-piloting. The burning gases travel the length of the combustion tube, flow around the outside of the inner tube, pass through cross-over passages into an outer radiating area, then travel the length of this surface and out the exhaust.

Ventilating air passes through the heater between the jacket and combustion tube assembly outer surface and through an inner passage in the assembly. Consequently ventilating air comes into contact with two or more heated, cylindrical surfaces.

THE ELECTRIC FUEL PUMP (Aviation Gasoline Applications) (See Figure 2-2)

For aviation gasoline applications, the electric fuel pump provides fuel at 7.0 psi for ground operation and during flight. (The heater may be operated from the engine fuel pump, provided the fuel pressure output is controlled within the operating pressure range of the heater).

a. Two (2) fuel pumps working in series can be used where the 7 psi pump is not able to provide sufficient fuel pressure.

Kerosene Fuel Applications (See Figure 2-3).

The electric fuel pump assembly is ideally suited to use, when needed, in aircraft heater fuel systems to provide proper pressures from fuel source, through a fuel control

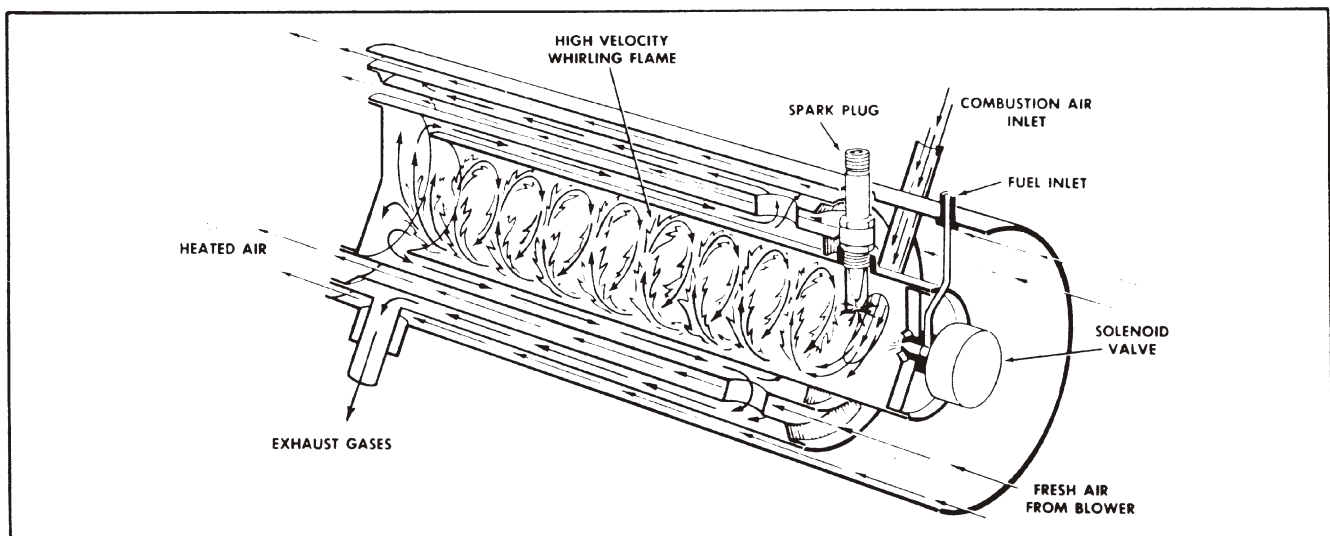

FIGURE 2-1 Diagrammatic Cutaway of Heater to Show Whirling Flame Action

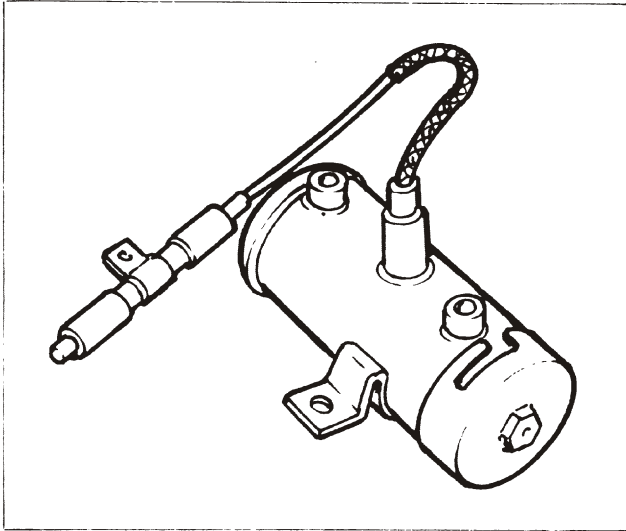

FIGURE 2-2 Electrical Fuel Pump - Aviation Gasoline

system to heater fuel nozzle. Pump supply is adequate for use with all kerosene burning heaters in the Janitrol Aero's line and can be mounted in a horizontal position, or vertically mounted provided the motor end of pump is at the top. Installation note: regardless of mounting position, an appropriate drain connection should be selected in the

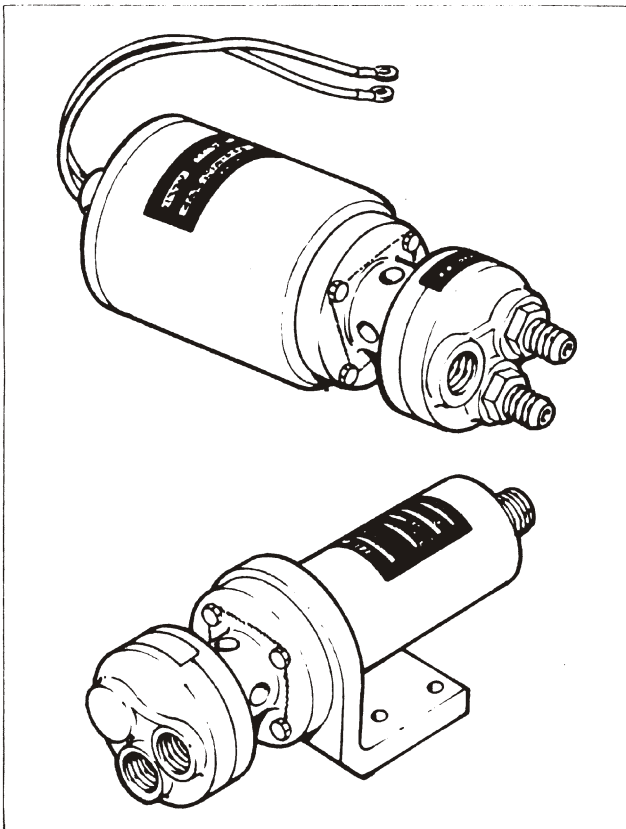

FIGURE 2-3 Electric Fuel Pumps used with Aviation Kerosene Fuel Applications.

adapter section (between motor and pump) so as to drain fuel in the event of pump seal leakage. Close the remaining drain openings using MS20913-IS plugs. The drain should always be on the bottom, connecting to 1/4" tubing that extends through bottom of aircraft, clearing outer "skin" or any other part of the aircraft. It should be scarfed at an angle approximately 30° to the direction of flight so as to create a negative pressure on the end of the drain. A fuel pressure relief valve must be used whenever this pump is part of installation.

Fuel connections are all standard pipe threaded.

THE PRESSURE RELIEF VALVE

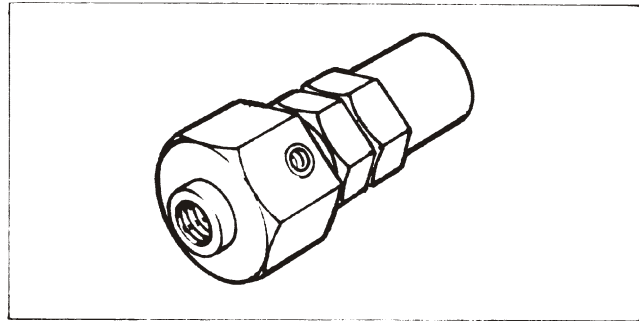

FIGURE 2-4 The Pressure Relief Valve

The relief valve is used, as its name implies, for relieving excessive pressure build-up in the heater fuel system. It must be used whenever kerosene fuel is used in an installation. It can be adjusted after installation in the system if a pressure gauge is temporarily installed on the outlet or regulated side of the fuel pump.

Fuel Regulator and Shutoff Valve (See Figure 2-5)
Refer to Janitrol Instruction Part No. 56D67

This unit provides preset, regulated fuel pressure as well as remote shutoff to the heater, regardless of fuel inlet pressure variations. It is available in 1.0, 7.5 and 12.0 psi settings depending upon installation requirements, with inlet pressures up to 50 psi. The shutoff valve is operated by a solenoid.

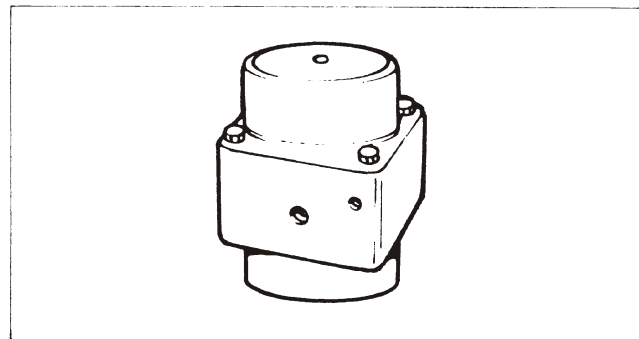
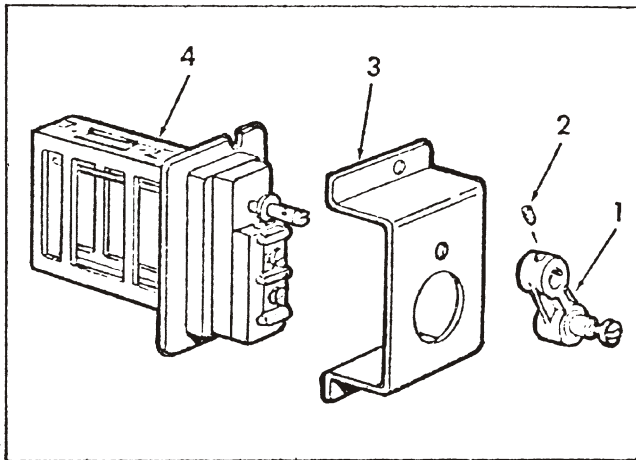

FIGURE 2-5 The Fuel Regulator and Shutoff Valve

Duct Switch

(See Figures 2-6-1 and 2-6-2)

This switch is installed in the ventilating air duct downstream from the heater to sense the ventilating air outlet temperature. To select the desired cabin temperature, the switch may be adjusted manually from a high of $250^{\circ} \pm 10^{\circ}$ downward through a range of 146° . Duct switches are also set at 195 to 225°F . The switch has a differential of $15^{\circ} \pm 5^{\circ}$ at any given setting.



- 1. Control lever
- 2. Setscrew
- 3. Switch cover
- 4. Adjustable duct switch

FIGURE 2-6-1 Duct Switch Assembly

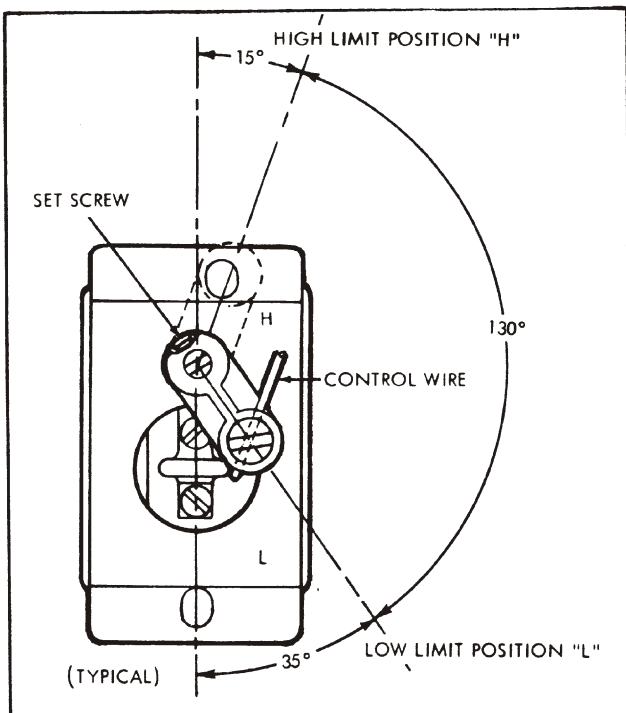

FIGURE 2-6-2 Top view of Duct Switch showing typical control lever positions.

Ventilating Air Blower

(See Figure 2-7)

This blower is attached to the inlet end of the heater assembly and provides a source of ventilating air through the heater. Ram air from the ventilating air intake scoop is normally used during flight. The blower can run continuously unless some provision is made to de-energize it during flight and use ram air exclusively. The hot line should be the circuit interrupted by a switch, not the line from blower to ground.

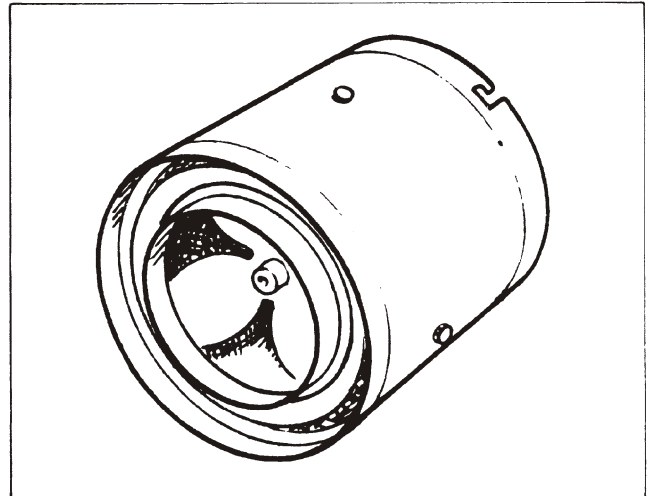

FIGURE 2-7 Vent Air Blower Assembly

Combustion Air Blower

(See Figure 2-8-1, 2-8-2 and 2-8-3)

This centrifugal-type blower is mounted separately from the heater to permit more flexibility to installation and supplies combustion air to the combustion chamber of the heater. Performance of the combustion air blower is assisted by the use of ram air during flight.

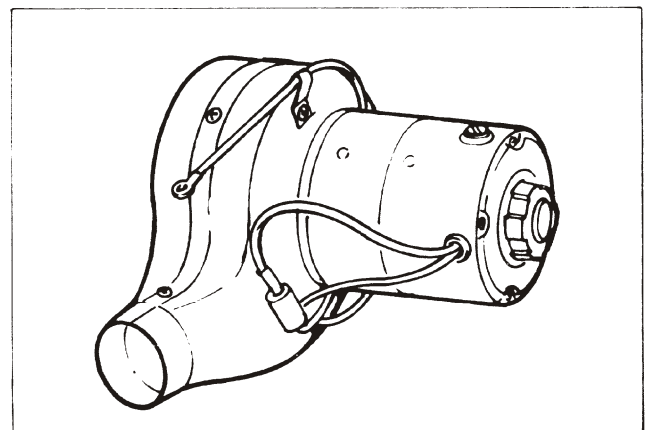

FIGURE 2-8-1 The Combustion Air Blower Assembly

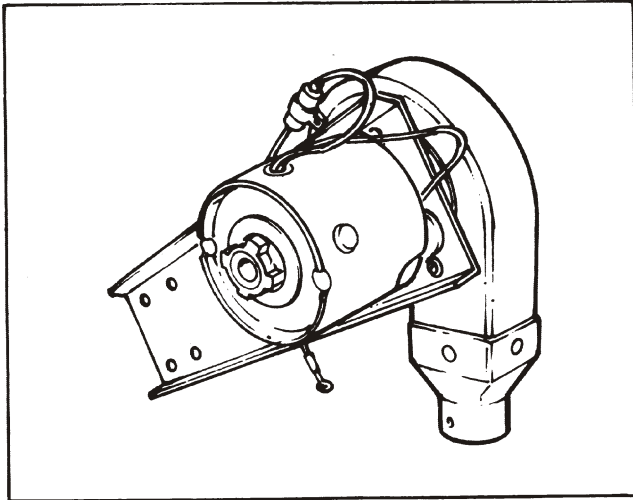

FIGURE 2-8-2 Combustion Air Blower

2.2 Operating Controls (See Figure 2-9)

The schematic diagram (Figure 2.9) shows in addition to the heater circuit, a suggested customer control circuit. For the purpose of this manual, this circuit will be used to describe heater operation. However, the customer control circuit can and will vary in different installations.

- a. The "Master Switch" is connected in the line that supplies electrical power to all heater equipment and controls. When this switch is in the "OFF" position, the entire heater system is inoperative. This switch can have a (vent) position which permits use of the ventilating air blower to circulate cool air through the system for summer ground operation. With the switch in "VENT" position, the heater is inoperative, and only the ventilating air blower is energized.
- b. The "HEATER START SWITCH" is a normally open, momentary "ON" switch that supplies power

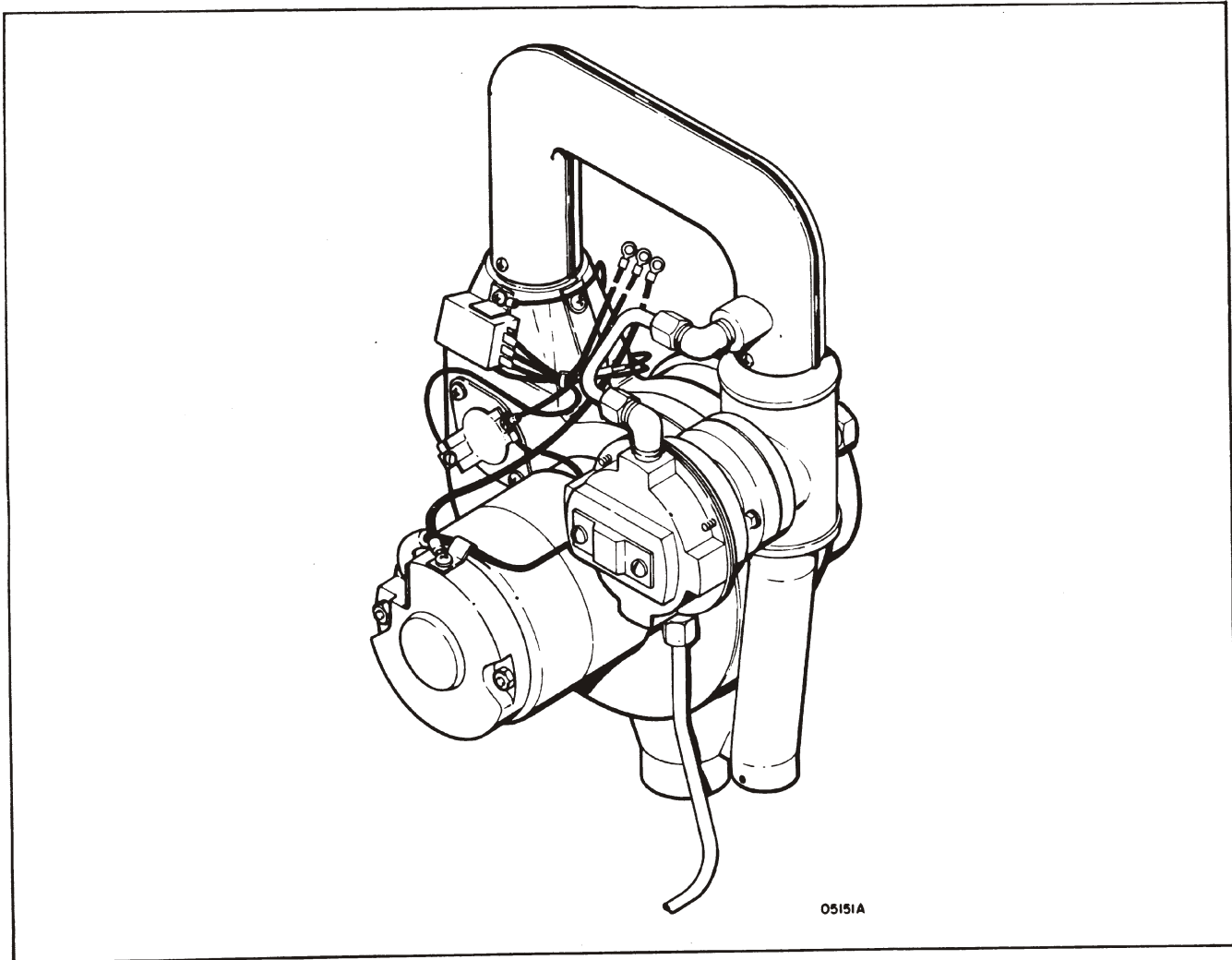

FIGURE 2-8-3 Combustion Air Blower and Regulator Assembly

to (lock-in) the safety relay through which power is supplied to the ignition and fuel circuits of the heater.

- c. The "HEATER STOP SWITCH" is a normally closed, momentary "OFF" switch that de-energizes or breaks the (lock-in) power to the safety relay to stop the heater fuel supply and ignition.

2.3 Operating Procedure (See Figure 2-9)

- a. Place the "MASTER SWITCH" in the "ON" (or "HEAT") position. The ventilating air and combustion air blowers should operate and the red "HEATER FAILURE LIGHT" should be on.
- b. Energize then release the HEATER START SWITCH. The red HEATER FAILURE LIGHT should de-energize (go out), and the green "HEATER RUNNING LIGHT" should energize (light). The heater will ignite and continue to operate. A short time lag may be required for the fuel pump to purge the fuel lines of air bubbles. This time lag should not be more

than ten seconds except in cases where the fuel line has been drained due to maintenance overhaul being performed.

- c. The "DUCT SWITCH" can be set to regulate the cabin temperature for desired comfort level. If this switch is set for ground operating comfort, it may be necessary to reposition it, since ram air will increase the ventilating air flow and the heater output.
- d. To stop heater operation, push, then release the "HEATER STOP SWITCH." The heater will de-energize and the red "HEATER FAILURE LIGHT" will then energize. The green "HEATER RUNNING LIGHT" will be de-energized.
- e. The blowers should be allowed to operate for several minutes to cool and purge the heater after operation. To stop blower operation, de-energize or turn "OFF" the "MASTER SWITCH."

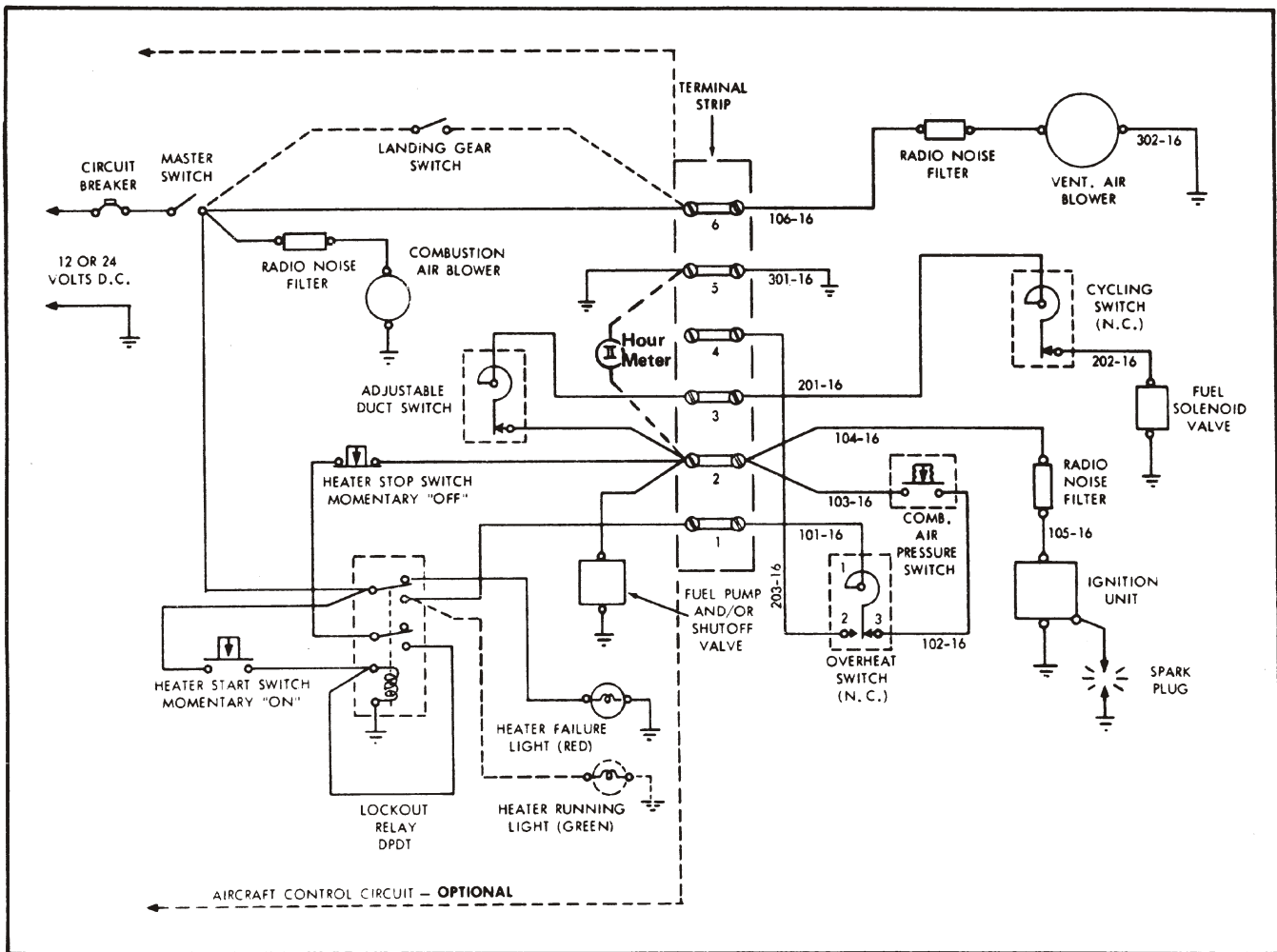

FIGURE 2-9 Wiring Diagram (typical)

SECTION III - MAINTENANCE SERVICE

Instructions contained in this section apply to Business and Utility Aircraft heaters covered in this manual. They consist of periodic inspection, adjustments, and minor corrections required at normal designated intervals for the purpose of maintaining the heating system in peak operating condition. These inspections assume that a heating system includes accessory components mentioned in preceding paragraphs.

3.1 Preflight and/or Daily Inspection

- a. Inspect the ventilating air inlet scoop, combustion air inlet scoop, exhaust outlet and fuel drain for possible obstructions. Make sure that all of these openings are clear of any restrictions and that no damage has occurred to air scoop protrusions.
- b. During preflight inspections look in the area of the combustion heater exhaust tube for large or unusual accumulations of soot on the skin of the aircraft. Soot accumulations are caused by the heater burning at a fuel "rich" condition. Incorrect fuel pressure to the heater, a restriction in the combustion air inlet line, a loss of performance by the combustion air blower, or partially clogged fuel nozzle are all causes of this condition and corrective maintenance should be performed.

3.2 Perform an operational check as follows:

- a. Place the "MASTER SWITCH" in the "ON" (or "HEAT") position. The ventilating air blower and combustion air blower should operate and the red "HEATER FAILURE LIGHT" should be energized.
- b. Operate both the combustion air blower and ventilating air blower and check each for unusual current draw, noise or vibrations. Refer to Table II for trouble shooting and for recommended maintenance.
- c. To proceed with the operational check, follow Paragraph 2.3 entitled "Operating Procedure", Steps A through E. This procedure should be repeated one or more times.

3.3 100 Hour Inspection*

The mandatory 100-Hour Inspection shall be conducted on new heaters or overhauled heaters with a new combustion tube assembly upon the accumulation of 500-heater hours or twenty-four (24) months, whichever occurs first, and thereafter at intervals not to exceed 100-heater hours or twenty-four (24) months, whichever occurs first. If a timing meter is used on the heater assembly, it should be connected across terminals Numbers 2 and 5 on the heater terminal strip. If a timing meter is not used count one (1) heater hour for each two (2) flight hours for normal aircraft operation. Consideration should be given for any excessive ground operation of the heating system. The 100-Hour Inspection consists of the functional checks/inspections as listed below and the Pressure Decay Test.

*NOTE: The term hours in this manual refers to heater hours of operation and not aircraft hours.

- a. Inspect ventilating air and combustion air inlets and exhaust outlet for restrictions and security at the aircraft skin line. If external scoops, jutting out into the air stream are used, make sure they are not distorted and are securely attached to the aircraft skin.
- b. Inspect the drain line to make sure it is free of obstructions. Run a wire through it if necessary to clear an obstruction.
- c. Check all fuel lines for security at joints and shrouds, making sure that no evidence of leaks exists. Also check for security of attachment of fuel lines at the various attaching points in the aircraft.
- d. Inspect electrical wiring at the heater terminal block and components for loose connections, possible chafing of insulation, and security of attachment points.
- e. Inspect the high voltage cable connection at the spark plug to make sure it is right. Also, examine the cable sheath for any possible indications of arcing, which would be evidenced by burning or discoloration of the sheath.
- f. Inspect the combustion air blower assembly for security of mounting, security of connecting tubing and wiring. Tighten any loose electrical terminals and air tube connections.
- g. Operate both the combustion air blower and ventilating air blower and check for unusual noise or vibrations. Refer to Table II for recommended maintenance.
- h. It is recommended that the condition of the spark plug be checked for operation as described in Paragraph 3.8.
- i. Following the 100 hour inspection, perform the preflight operating check as described in Paragraph 3.1.

NOTE

Due to certain flight patterns, the sensing tube from the pressure switch to heater exhaust may be clogged. Disconnect at switch and clear tube by blowing air through it. If combustion product residue has collected in the exhaust end of the tube, it may be necessary to clear the sensing tube with a wire.

3.3.1 Pressure Decay Test Setup

Evaluation of the condition of the combustion chamber shall be made at the 100 hour inspection. This test is intended to be accomplished while the heater is installed with a minimum of accessory disconnection. When necessary or desired for convenience, the heater assembly may be removed from the aircraft to conduct the pressure decay test.

The following equipment is necessary to conduct the Pressure Decay Inspection Test.

1. Pressure Decay Test Kit, Part No. 26E24-1.
2. 1/4-inch air supply line with 0-10 PSIG pressure gage, shutoff valve and air pressure regulator. (B), See Figure 3-1.
3. 1/4-inch air supply line with 0-100 PSIG pressure gage, shutoff valve and air pressure regulator. (A), See Figure 3-1.

To conduct the pressure decay test, the heater must first be sealed at all openings into the combustion chamber assembly. The openings into the combustion chamber include the combustion air inlet tube, combustion air pressure switch differential sensing lines, fuel drain, and the exhaust tube. (See Figure 3-1) Loosen and remove all flex tubing, elbows and adapter, that may be mounted between the combustion air blower and the heater.

NOTE

The Combustion Air Pressure Switch must not be pressurized during the pressure decay test.

The remaining steps necessary to prepare for the pressure decay test are listed in paragraphs 3.3.2 thru 3.3.9.

3.3.2 If the Combustion Air Pressure Switch is mounted directly on the heater, loosen the Combustion Air sensing lines from the Combustion Air Pressure Switch. Identify and then loosen two (2) wires from the Combustion Air Pressure Switch. Remove the Combustion Air Pressure Switch from heater by unscrewing the switch from the fitting.

3.3.3 Loosen and remove any aircraft mounted exhaust tube and exhaust tube shroud from the heater assembly

and obtain access to the heater mounted exhaust tube.

3.3.4 Install pressure seals on Combustion Chamber using the parts supplied in the Combustion Chamber Pressure Decay Test Kit (Part No. 26E24-1) (See Figure 3-2). The following attachments are to be made on the heater.

Install and tighten in place (as shown on Figure 3-3) the Combustion Air Tube Pressure Supply Assembly (Part No. 26E26-1) using the hose clamps (Part No. 26E25-1). Attach 1/4-inch supply line as shown in Figure 3-1 or 3-5. Install and tighten cap (Part No. 11E97-1) on fitting where combustion air pressure switch was mounted. (See Figure 3-2 and 3-3)

3.3.5 Loosen the overboard drain line from the heater and install a pipe cap (Part No. 11E97-2) if the drain fitting is equipped with a 1/4-inch pipe thread or install a pipe plug (Part No. AN 933-1) if the drain fitting has a 1/8-inch internal pipe thread.

Note that Heater Part Number 81D94 is equipped with two (2) drains. Both drains must be capped.

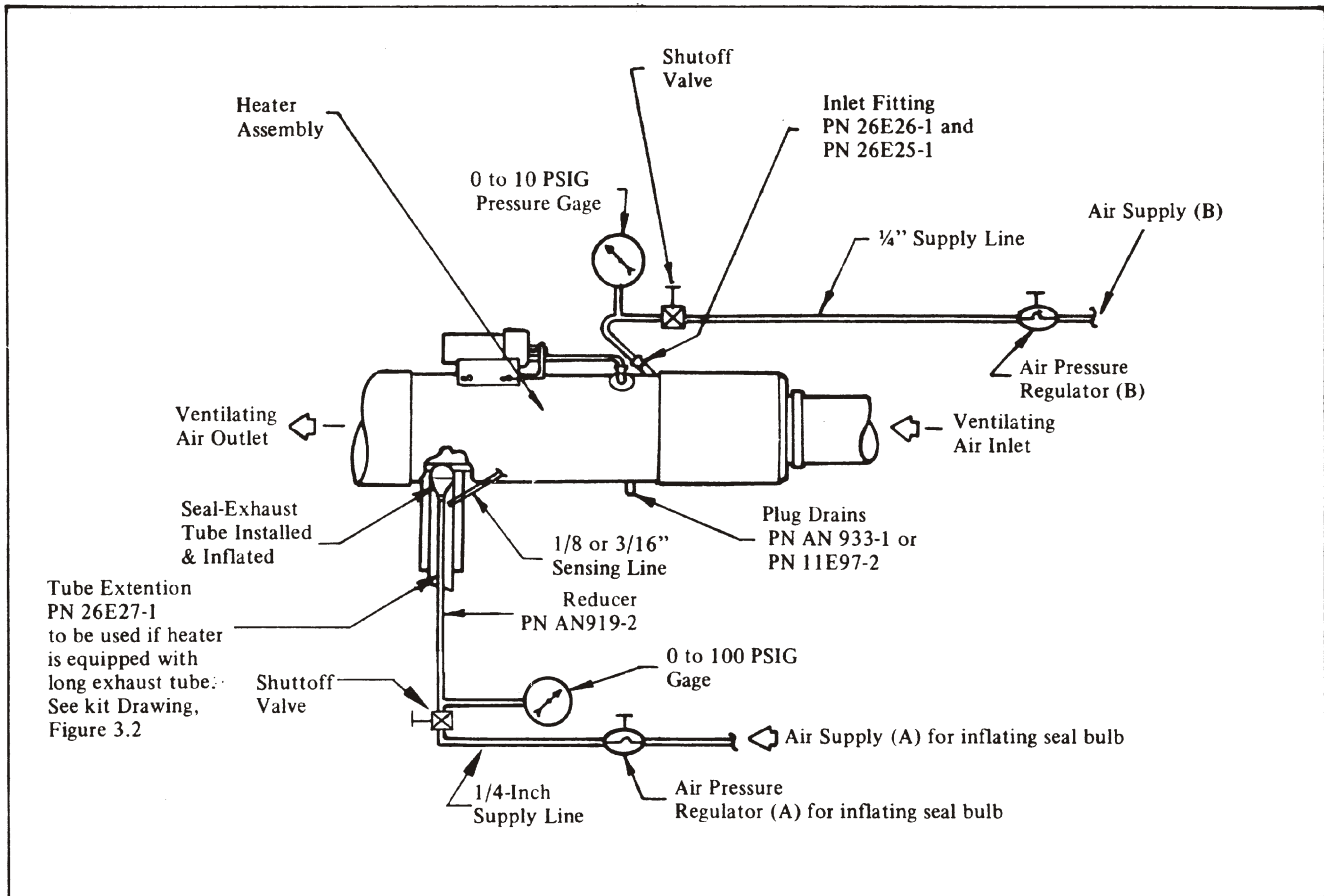
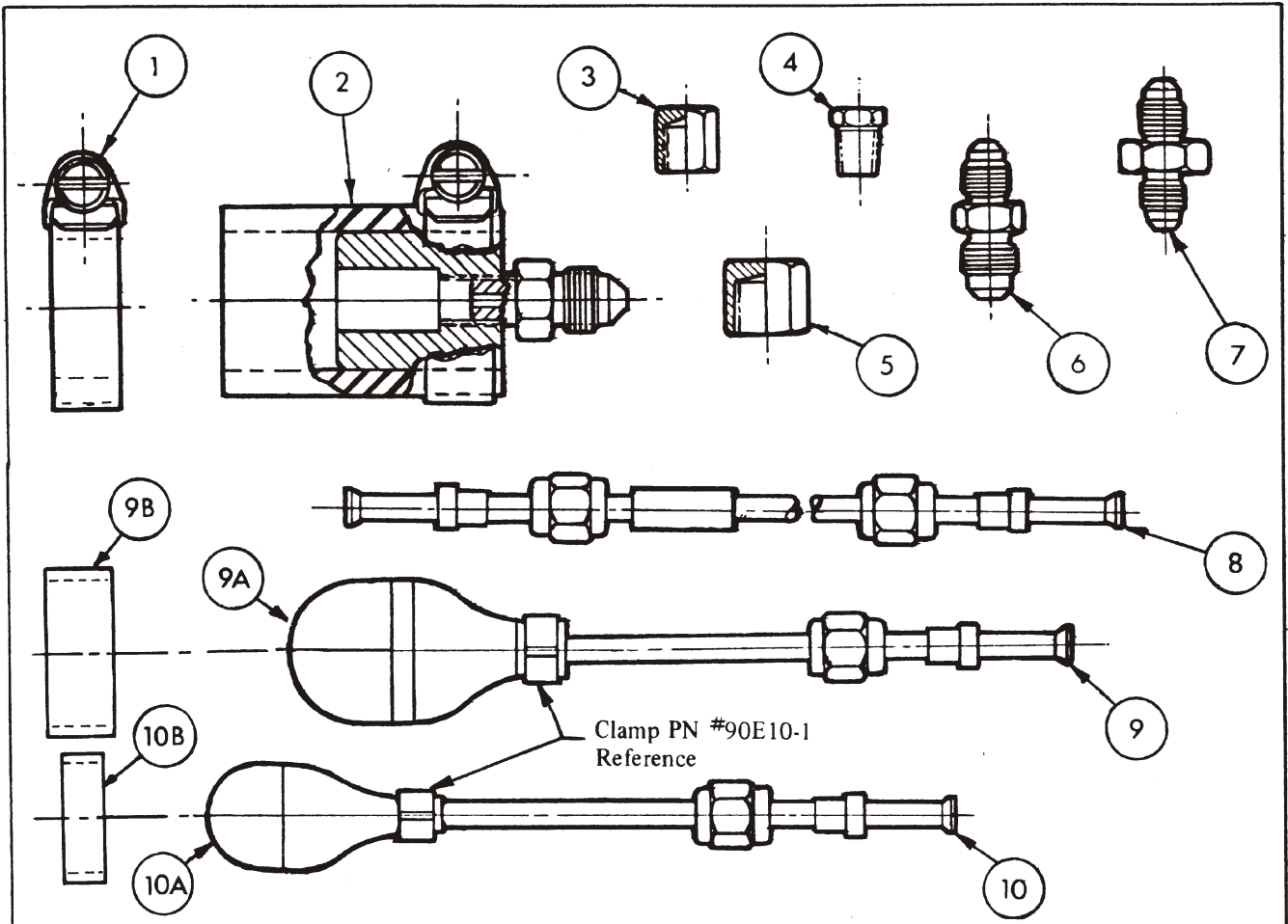

FIGURE 3-1 Test Set-Up Pressure Decay Inspection Test



| ITEM NO. | PART NUMBER | DESCRIPTION |
|----------|-------------|--|
| -1 | 98C27-2 | Clamp – Hose, Worm Drive |
| -2 | 26E26-1 | Combustion Air Tube – Pressure Supply Assembly |
| -3 | 11E97-1 | Cap – 1/8-inch Pipe Threads – Combustion Switch Fitting |
| -4 | 90E25-1 | Plug-Hex, 1/8-inch Pipe Thread – Drain Plug |
| -5 | 11E97-2 | Cap – 1/4-inch Pipe Thread – For Drains with 1/4-inch Exterior |
| -6 | MS24399-3 | Reducer 1/4-inch Tube to 3/16-inch Tube |
| -7 | 90E24-1 | Union 3/16-inch Tube |
| -8 | 26E27-1 | Tube Assy – Extension – 3/16-inch Diameter – For Item -7, -9, and/or -10 |
| -9 | 26E29-2 | Seal Assy – Exhaust Tubes – 2-inch Nominal Diameter |
| -9A | 90E06-2 | Seal Bulb, 2-inch (1 extra supplied) |
| -9B | 90E23-2 | Sealing Ring, 3/4" wide for 2" exhaust tube |
| -10 | 26E29-1 | Seal Assy – Exhaust Tubes – 1 1/2-inch Nominal Diameter |
| -10A | 90E06-1 | Seal Bulb, 1 1/2-inch (1 extra supplied) |
| -10B | 90E23-1 | Sealing Ring, 1/2" wide for 1 1/2" exhaust tube |
| -11 | 28E87-1 | Instruction Sheet |

FIGURE 3-2 Combustion Tube Pressure Decay Test Parts Kit (Part No. 26E24-1)

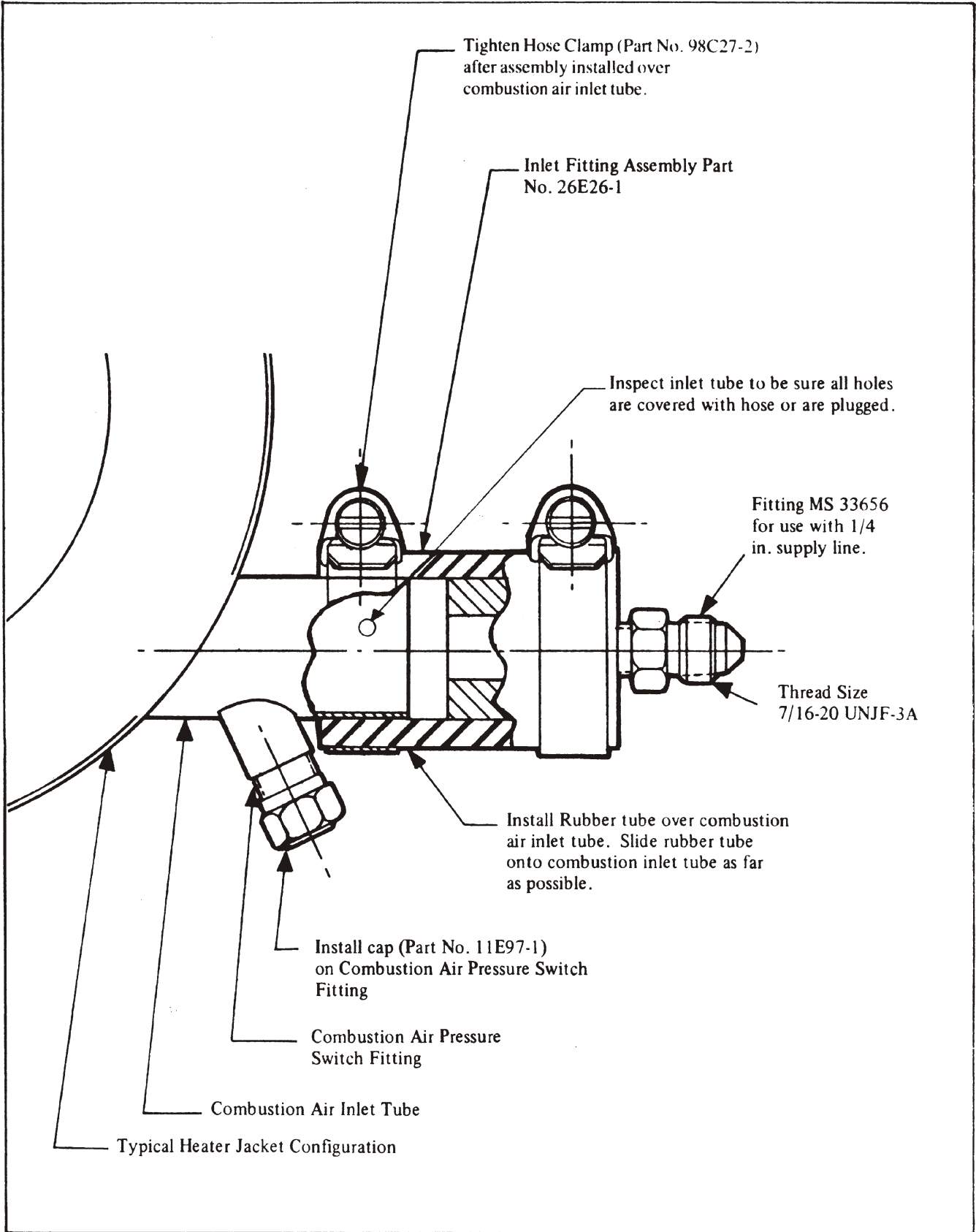

FIGURE 3-3 Combustion Air Tube – Pressure Supply Assembly Installed

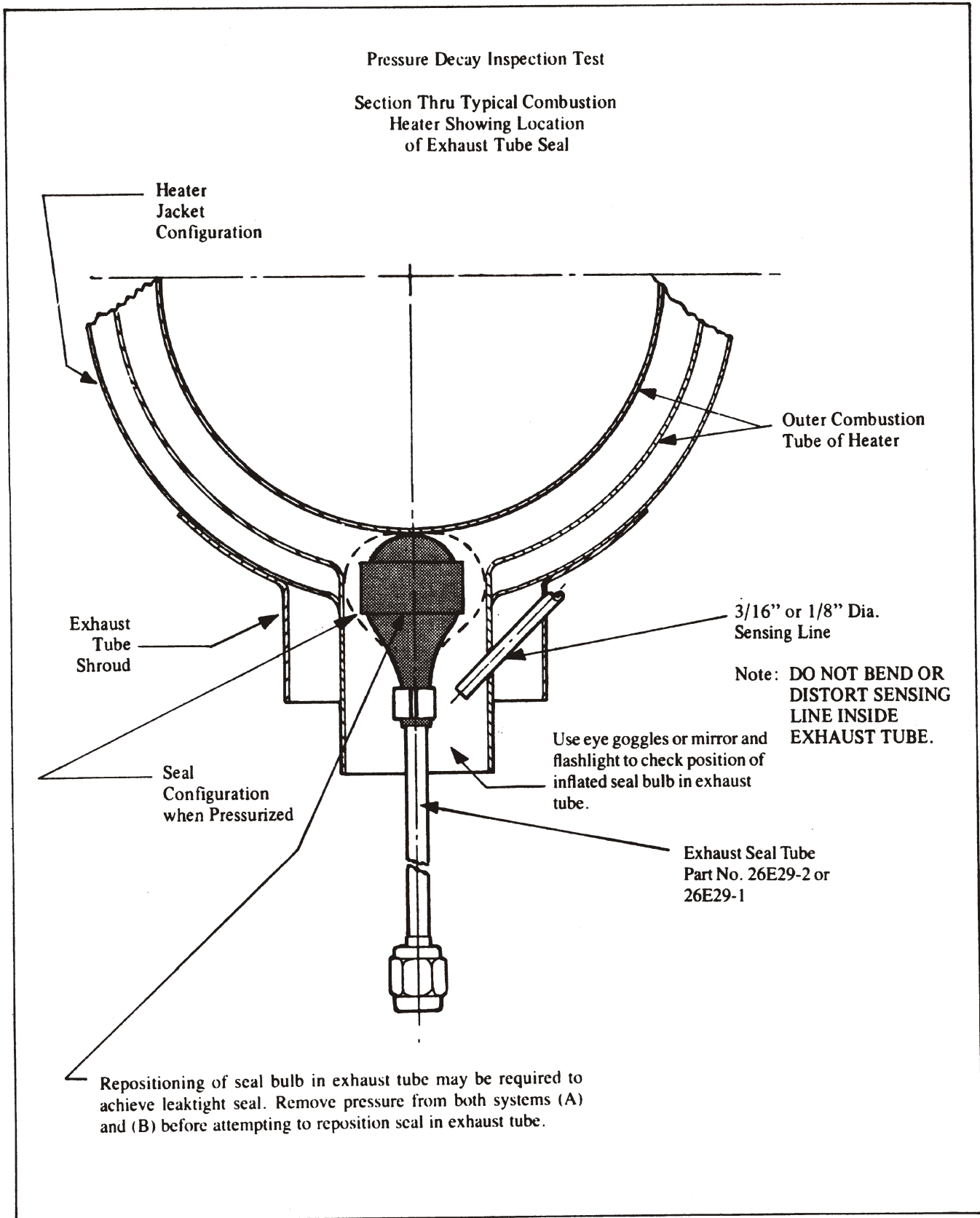

FIGURE 3-4 Exhaust Tube Seal Shown Installed Just Prior to Inflation

3.3.6 - Visually inspect exhaust tube of heater to determine the nominal diameter of exhaust at the area to be sealed. (See Figure 3-4) Check exhaust tube for sharp projections that could damage the rubber bulb of the exhaust seal tube during inflation. For exhaust tubes of 1½ inch nominal diameter, the Exhaust Seal Part No. 26E29-1 should be used. For 2 inch nominal diameter exhaust tubes use the Exhaust Seal Part No. 26E29-2. Products of combustion may need to be cleaned from inside of exhaust tube if the build-up is large enough to keep the bulb from sealing. Deposits may be removed by brushing or scraping.

3.3.7 Attach the correct size exhaust seal tube to the pressure supply system as shown in Figure 3-5. For longer exhaust tubes, the Tube-Extension Part No. 26E27-1 will be required for the seal to be fully inserted.

CAUTION

VISUALLY INSPECT PER FIG. 3-4 TO BE SURE THAT RUBBER BULB PART OF EXHAUST SEAL TUBE IS INSERTED PAST THE 1/8 OR 3/16 INCH DIAMETER SENSING LINE THAT STICKS INTO THE EXHAUST TUBE.

DO NOT BEND OR DISTORT THE LOCATIONS OF THE 1/8 OR 3/16 INCH SENSING LINE INSIDE THE EXHAUST TUBE

DO NOT ATTEMPT REPAIR OR USE A DAMAGED SEAL BULB AS IT MAY RUPTURE SUDDENLY WHEN PRESSURIZED.

After the seal is properly inserted into the exhaust tube, and while holding it in place, slowly inflate the seal to 70±5 psig pressure using the regulated supply air (A) as shown in Figure 3-5. When properly installed and inflated, the seal will hold itself in place. After seal is properly installed and pressurized, close the shutoff valve on the line as shown in Figure 3-5, to check for leakage from the bulb.

3.3.8 Attach a supply line to the fitting on the Combustion Air Inlet Seal Fixture. Slowly apply 2 or 3 psig of air pressure from the regulator (B) as shown in test set-up diagram to check that exhaust seal is leaktight. Pressure in the exhaust seal, air supply (A), may be increased to 95 psi max. if required to achieve leaktight seal.

3.3.9 Check all seals for security and leak-tightness using a soap and water solution or other available method. When all seals, caps and plugs are leak proof start the Pressure Decay Test.

3.3.10
Pressure Decay Test

Apply 6.0±.5 psig to the combustion chamber through the air pressure supply regulator (B) as shown on the test set-up diagram. Figure 3-5.

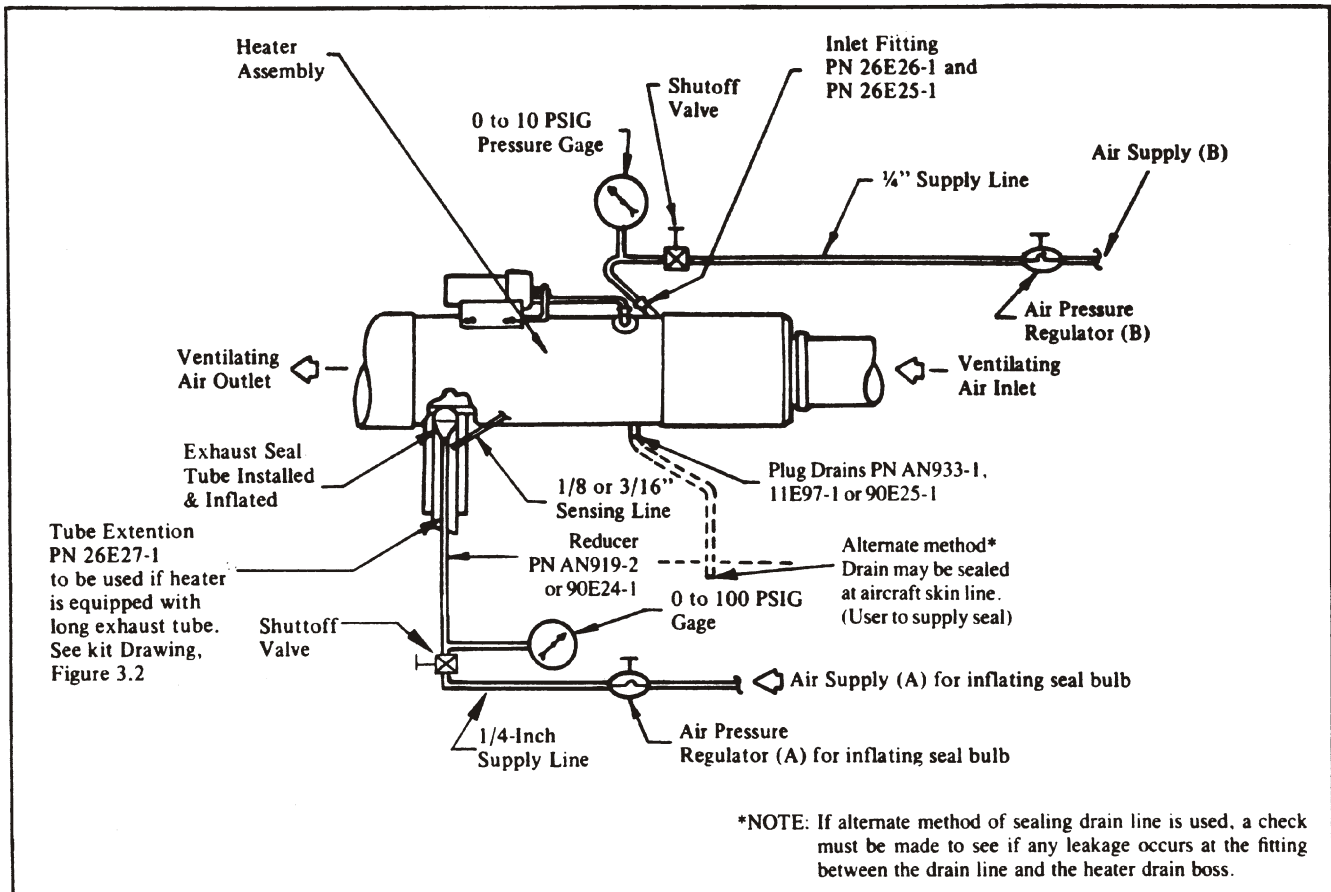

FIGURE 3-5 Test Set-Up Pressure Decay Test
(Figure 3-5 is identical to Figure 3-1 and is repeated here for convenience to reader)

After the pressure reaches 6.0±.5 psig and stabilizes, close off the shutoff valve at heater and start the timer. (This valve should be checked for leak tightness prior to the start of testing as should all connections.)

After 45 sec. the pressure in the combustion chamber must exceed 1.0 psig.

If the pressure decays to less than one (1) psig before the 45 sec., that indicates a leak is present either in the combustion chamber or around the seals. Re-check all the seals installed on the combustion chamber for leak tightness and rerun the Pressure Decay Test.

If the heater continues to show rapid pressure decay of the combustion chamber, the heater must be removed from the aircraft, and a more complete inspection be made to determine location of the leak.

3.3.11 Deflate seal in exhaust tube and remove carefully to avoid damaging either the rubber section of the seal or the 1/8" or 3/16" diameter sensing line that protrudes into the side of the exhaust tube before removing heater from the aircraft.

3.3.12 After the heater is removed from the aircraft, conduct the pressure decay test again to check for leaks at the spark plug seat, the fuel feed inlet gasket, screw heads, and weld seams prior to tear-down for necessary overhaul. High temperature PERMATEX 1372W may be applied to screw threads to stop leaking, if required.

3.3.13 Following the successful completion of the Pressure Decay Test, remove all test fittings, plugs, supply lines, etc., and re-install required sensing line, combustion air supply lines, drain lines which make up the aircraft installation. Reconnect drain lines and exhaust tubes and shrouds.

The Combustion Air Pressure Switch should be tested in accordance with Paragraph 4-9-C prior to being re-installed on the heater.

The heater assembly should be overhauled after 1,000 hours of operation or whenever it fails to pass the Pressure Decay Test. Whenever the heater requires overhaul, all accessories should be removed, operationally checked and overhauled as indicated in Section IV of this manual.

3.4 Trouble Shooting

The following service troubles and suggested remedies (Table II) is provided to assist in locating and correcting malfunctions in the heating system. The following procedure is based upon the use of heater assembly and the optional components.

3.5 Electrical Check

These tests are listed as an aid in isolating open circuited or inoperative electrical components, should the heater fail to light with the "MASTER" switch and "HEATER

START SWITCH" energized. (See Figures 3-6 through 3-8.)

NOTE

The schematic wiring diagrams (Figures 3-6 through 3-8) show, in addition to the heater circuitry, a suggested aircraft control circuit. For the purposes of this manual, the circuitry shown in these illustrations will be utilized to describe electrical checks. However, the aircraft control circuit can vary in different installations and also the heater circuit.

For the purposes of this manual, all tests will be based on a 24-volt DC heater circuit. For a 12-volt DC heater operation, change all 24-volt references to 12-volt.

It must be assumed that power, which is furnished through the aircraft circuit breaker, is present at the "MASTER" switch at all times. Always check the circuit breaker before performing electrical checks. Check the primary power circuit as follows:

- a. With the "MASTER" switch energized, voltage (24-volts nominal) should be present at the following locations (See Figure 3-6):
 - (1) Terminal No. 6 on the heater terminal strip.
 - (2) From terminal No. 6 of the heater terminal strip to the ventilating air motor.
 - (3) The combustion air blower will be energized.
 - (4) To the common connection of the DPDT relay in the suggested aircraft control circuit.
 - (5) To one side of the heater start switch.

In the event that voltage is not present at one or more of the above listed points, the wiring must be traced back to the power source. If components are still inoperative after the wiring inspection, check individual inoperative components to determine faulty operation and, if necessary, replace them.

TABLE II
SERVICE TROUBLES AND SUGGESTED REMEDIES

| TROUBLE | PROBABLE CAUSE | REMEDY |
|------------------------|--|---|
| Heater fails to light. | Master switch or circuit breaker off. | Turn on master switch or close circuit breaker. |
| | Low voltage supply. | Apply external power supply. Attempt to start heater. (Refer to para. 2.3.) |
| | Fuel cut off from tank. | Turn on manual shutoff valve (if used) or master solenoid. |
| | Suction leak ahead of pump. | Secure all fittings. |
| | Insufficient fuel pressure. | Low or no current to fuel pump. Check for operation of pump and remove for repairs if not operating. (Refer to para. 3.11.) |
| | Regulator not operating properly. | Check for low pressure or replace regulator. (Refer to para. 3.14.) When making fuel pressure check, be sure fuel is flowing through nozzle. Turn adjusting screw clockwise to increase fuel pressure and counterclockwise to decrease. |
| | Fuel pump operating but not building up sufficient pressure. | Remove and repair or replace fuel pump. (Refer to para. 3.11.) |
| | Restriction in fuel nozzle orifice. | Remove the nozzle and clean or replace it. (Refer to para. 4.1, l, m and n; 4.7, i; and 4.11, k and l.) |
| | Fuel heater solenoid not operating. | Remove and check solenoid. Replace if faulty. (Refer to para. 4.1, q; 4.7, k and 4.11, a.) |
| | Fuel lines clogged or broken. | Inspect all lines and connections. It may be necessary to disconnect lines at various points to determine where the restriction is located. |
| | Fuel filter clogged. | Clean fuel filter element. Check for ice in fuel system. |
| | Ignition vibrator inoperative. | Replace vibrator; check for defective radio noise filter. (Refer to para. 3.9.) |
| | Manual reset limit (overheat) switch open. | Press reset button firmly and recheck to determine reason for switch opening. |
| | Combustion air pressure switch open. (Defective switch or low combustion air blower output.) | Check for low blower output due to low voltage and correct it. If switch is defective, replace it. (Refer to para. 3.3.) (NOTE) |
| Cycling switch open. | Replace if defective. (Refer to para. 3.12.) | |
| Duct switch open. | Operate control to see if switch will come on. Replace switch if defective. (Refer to para. 3.15.) | |

TABLE II
SERVICE TROUBLES AND SUGGESTED REMEDIES (Cont.)

| TROUBLE | PROBABLE CAUSE | REMEDY |
|--------------------------------------|--|---|
| Ventilating air blower fails to run. | <p>“MASTER” switch “OFF”. Broken or loose wiring to motor.</p> <p>Circuit breaker open.</p> <p>Worn motor brushes.</p> <p>Blower wheel jammed.</p> <p>Motor burned out.</p> <p>Defective radio-noise filter.</p> | <p>Energize the “MASTER” switch. Check and repair wiring.</p> <p>Close circuit breaker.</p> <p>Replace motor brushes. (Refer to para. 3.7, b.)</p> <p>Remove and check the ventilating air blower wheel and realign if necessary. (Refer to para. 4.11, g.)</p> <p>Remove blower assembly and replace motor. (Refer to para. 4.1, l and r through u; 4.11, b through g.)</p> <p>Replace filter.</p> |
| Combustion air blower fails to run. | <p>Faulty wiring to motor.</p> <p>Poor ground connection.</p> <p>Worn motor brushes.</p> <p>Blower wheel jammed. (Usually indicated by hot motor housing.)</p> <p>Defective radio-noise filter.</p> <p>Faulty or burned-out motor.</p> | <p>Inspect and replace faulty wiring.</p> <p>Tighten ground screw. Be sure any metal preservation has been removed for good ground connection.</p> <p>Replace motor brushes. (Refer to para. 3.7, b.)</p> <p>Overhaul the combustion air blower. (Refer to paras. 4.2 and 4.12.)</p> <p>Replace filter. (Refer to paras. 4.2 and 4.12.)</p> <p>Remove combustion air motor for overhaul or replacement of motor. (Refer to paras. 3.7, 4.2 and 4.12.)</p> |
| Heater fires but burns unsteadily. | <p>Insufficient fuel supply. Ice or water in system fuel lines.</p> <p>Spark plug partially fouled.</p> <p>Loose primary connection at ignition assembly.</p> <p>Faulty vibrator.</p> <p>Combustion air blower speed fluctuates. (Can be caused by low voltage, loose blower wheel, worn brushes or motor.)</p> <p>High voltage leak in lead between ignition assembly and spark plug.</p> <p>Inoperative ignition assembly.</p> <p>Restriction in fuel nozzle orifice.</p> <p>Nozzle loose in retainer or improper spray angle.</p> | <p>Inspect fuel supply to heater including shutoff valve, solenoid valve, fuel filter, fuel pump and fuel lines. Make necessary repairs.</p> <p>Replace spark plug. (Refer to para. 3.8.) CAUTION: Do not create spark gap by holding lead to heater jacket. This can result in damage to lead and ignition unit and operator may receive an electrical shock.</p> <p>Tighten the connection.</p> <p>Replace the vibrator. (Refer to para. 3.9.)</p> <p>Remove and overhaul the combustion air blower assembly as required or correct low voltage condition. (Refer to paras. 3.7, 4.2, 4.9 and 4.12.)</p> <p>Replace ignition assembly. (Refer to para. 3.10.)</p> <p>If vibrator is in good condition, replace ignition assembly only. (Refer to para. 3.10.)</p> <p>Remove nozzle for cleaning or replacement. (Refer to paras. 4.1, m and n; 4.7, i; and 4.11, k and l.)</p> <p>Tighten or replace the nozzle as required. (Refer to paras. 4.9, e; 4.11, k.)</p> |

TABLE II
SERVICE TROUBLES AND SUGGESTED REMEDIES (Cont.)

| TROUBLE | PROBABLE CAUSE | REMEDY |
|------------------------------|---|---|
| Heater starts then goes out. | Lack of fuel at heater. | Check fuel supply through all components from the tank to the heater. Make necessary corrections. |
| | Inoperative or chattering combustion air pressure switch. | Check, adjust, or replace switch. (Refer to para. 3.13.) |
| | Inoperative overheat switch. | Check or replace switch. (Refer to paras. 3.12 and 5.4.) |
| | Inoperative cycling switch. | Adjust or replace the switch. (Refer to paras. 3.12 and 5.4.) |
| | Low voltage. | Attach external power. |
| Heater fails to shut off. | Fuel solenoid valve in heater stuck open. | Remove and replace solenoid assembly. (Refer to paras. 4.1, q; 4.7, k; and 4.11, a.) |
| | Inoperative duct and cycling switch. | Check and repair. (Refer to paras. 3.12 and 3.15.) |
| | Defective "MASTER" switch. | Replace the master switch. |

To conduct voltage tests on the starting power circuit, proceed as follows (See Figure 3-7):

- b. With the "MASTER" switch in the energized position energize or turn on the "HEATER START SWITCH" after which voltage should be present at the following locations:
- (1) One side of the relay coil, through the relay coil, to ground.
 - (2) To the normally open side of the double-pole, double-throw relay.
 - (3) One side of the double-pole, double-throw relay to terminal No. 1 of the heater terminal strip.
 - (4) From terminal No. 1 of the heater terminal strip to the common connection (No. 1) of the overheat switch.
 - (5) From terminal No. 3 of the overheat switch through the combustion air pressure switch to terminal No. 2 of the heater terminal strip.
 - (6) From terminal No. 2 of the heater terminal strip through the heater stop switch to the common connection of the double-pole, double-throw relay through the relay, to the relay coil, to ground, to provided a lock-in circuit for the relay.

NOTE:

Whenever this circuit is interrupted by either tripping or de-energizing the "HEATER STOP SWITCH," or malfunction of the "COMBUSTION AIR PRESSURE SWITCH" or "OVERHEAT SWITCH," the heater system is de-energized and cannot be operated until such time as the inoperative component is replaced.

Tests may be conducted on the running power circuitry as follows (See Figure 3-8):

- c. From terminal No. 2 of the heater terminal strip to the following locations:
- (1) Through the radio-noise filter to the ignition assembly.
 - (2) To the fuel pump and/or shutoff valve.
 - (3) Through the duct switch to terminal No. 3 of the heater terminal strip.
 - (4) From terminal No. 3 of heater terminal strip to the cycling switch, through the cycling switch to the fuel solenoid valve.

It should be remembered that the suggested control circuit will vary with each installation. Please note that terminal No. 2 of the "OVERHEAT SWITCH" is connected to the heater terminal strip No. 4. For some installations a red

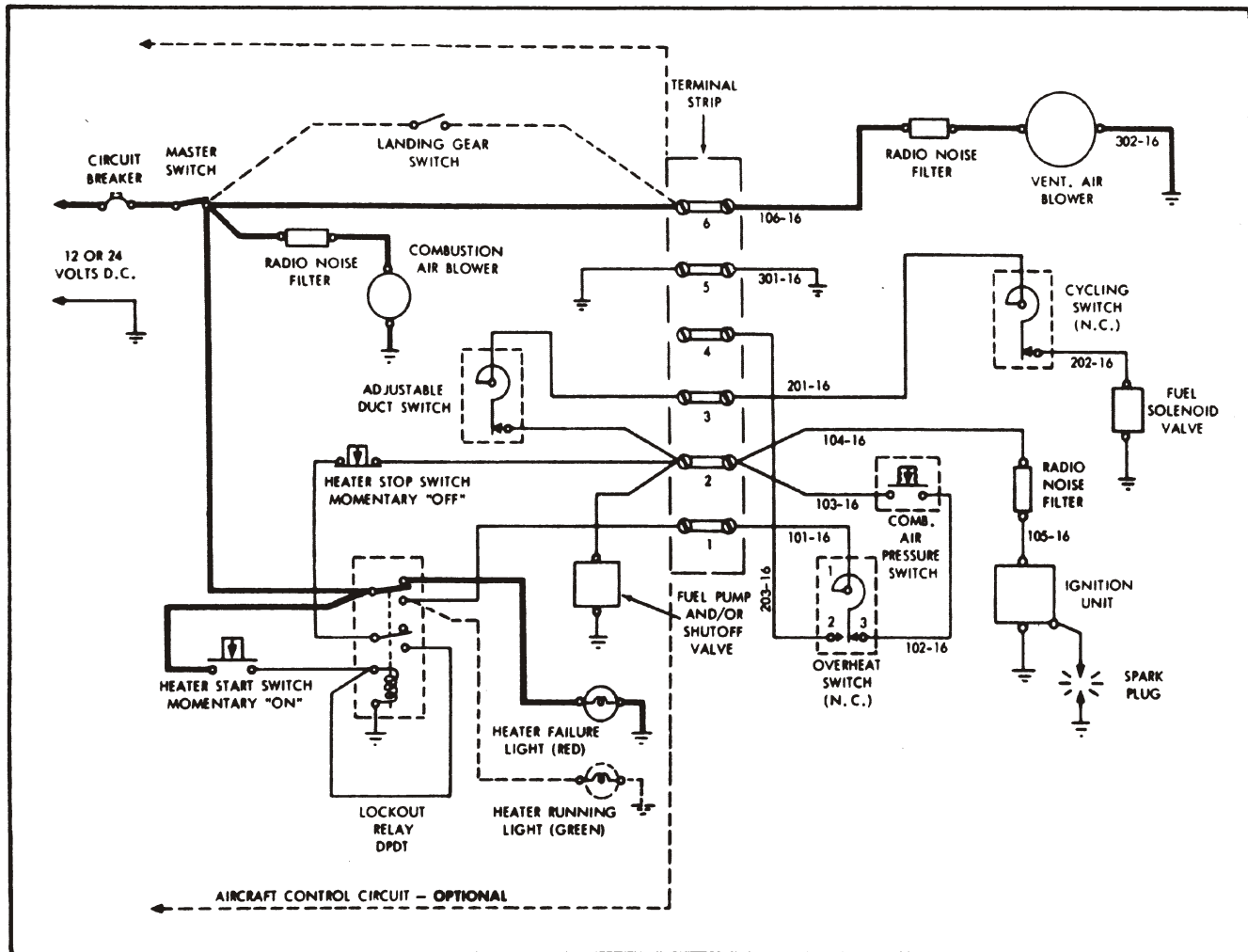

FIGURE 3-6 Primary Power Circuit (Typical)

failure light may be connected to the aircraft side of terminal No. 4 to indicate malfunction of the overheat switch.

3.6 General Maintenance

Instructions in this paragraph pertain to maintenance of the basic heater and components while the heater is installed in the aircraft. Instructions for removal of components are included provided the installation permits accessibility.

NOTE:

No special service tools are required for normal periodic maintenance of Janitrol aircraft heaters.

3.7 Combustion Air Blower

a. Removal

- (1) Remove access panels if necessary to reach the combustion air blower assembly.
- (2) Disconnect the electrical cable connection at the

most convenient location. (See Figure 3-6.)

(3) Disconnect the air tube between the blower and combustion air adapter on the heater. If the combustion air blower inlet adapter is used, disconnect it from the inlet tubing. This will depend upon the type of connecting tubing used and the method of attachment.

(4) Disengage the clamp that secures the combustion air blower and remove the blower motor assembly. It will usually be possible to remove the assembly by loosening the clamp and sliding the motor out of the clamp. In some installations it is easier to remove blower and mounting bracket from the aircraft.

- b. (1) Remove the brush cap at one of the brush locations. Note position of brush inside the guide and carefully lift the brush and brush spring out of the guide. Be sure to hold the brush so that it can be re-installed in the same position, if no brush replacement is required. On Motor Part No's. 27D39 and 34D30 it is necessary to remove motor case to replace brushes.

- (2) Inspect the brush for wear. If brushes are worn to a length of 3/16" or less they must be replaced.
- (3) Looking through the brush guide, inspect the commutator, which should be smooth and medium brown to dark brown in color. Remove all dust from commutator with compressed air. If the commutator is grooved in, the brush track, gouged, scored or shows signs of having burned spots, replace the complete motor assembly. If the commutator is in good condition, install new motor brushes, and tighten brush caps into place. Make sure each brush is oriented so that the curved end fits the curvature of the commutator.
- (4) After installing new brushes, it is advisable to run-in the brushes as follows:
Connect the motor to a controlled voltage supply (rheostat in a 28-volt DC line for 28-volt motor and a 12-volt line for 12-volt motor). Operate the motor at approximately 1/2 its normal speed for the first hour, then gradually increase the speed until it is rotating at approximately normal speed. Continue the

c.

run-in operation for at least two hours to properly seat the brushes before installing the blower in the aircraft.

Installation

- (1) Prior to installing the combustion air blower, inspect all parts of the assembly for loose screws, loose nuts, and poor ground connection on the blower housing. Make sure the blower wheel is tight on the shaft and properly located in the housing. It should have just enough clearance to rotate at full speed without binding against the spill plate. Blower performance is based upon this close-tolerance clearance. It is recommended that correct voltage be applied for this clearance check.
- (2) Install the blower inlet adapter in the same orientation as before removal (not used on all installations).
- (3) Place the combustion air blower assembly in position in the attaching clamp so the air tubing can be connected and slide the tubing into position at the point where it was disconnected during removal. Do

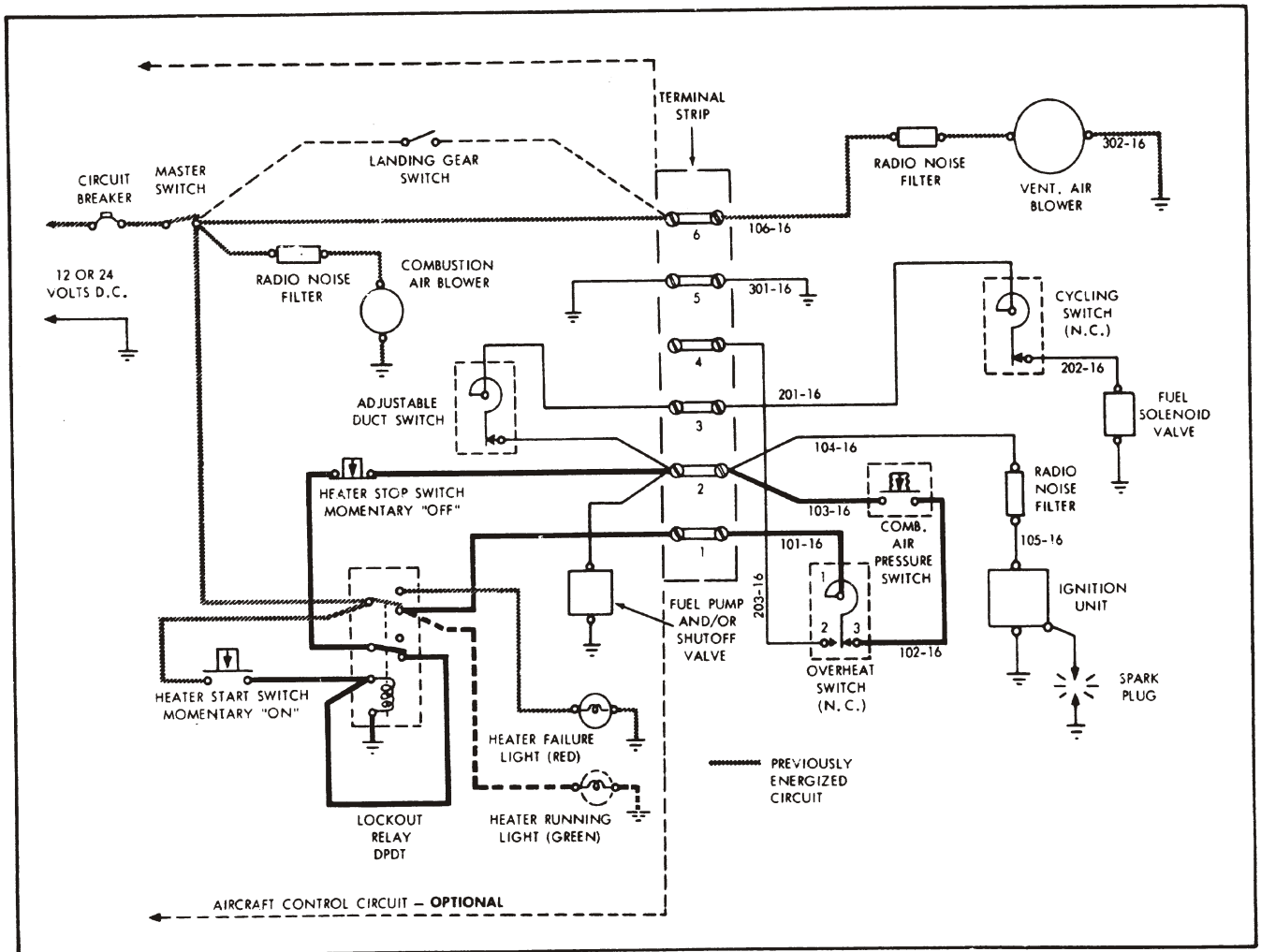

FIGURE 3-7 Starting Power Circuit (Typical)

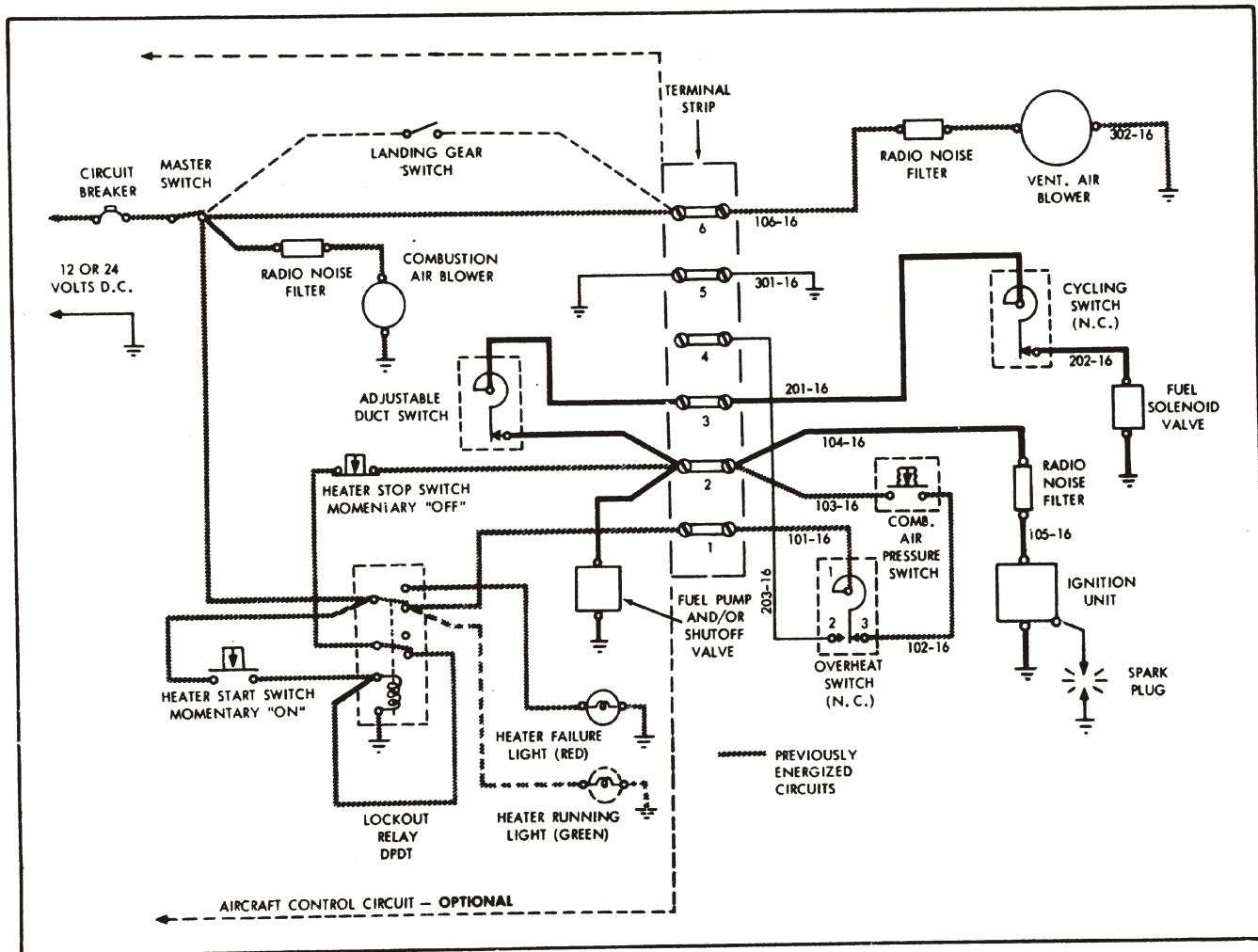

FIGURE 3-8 Running Power Circuit (Typical)

not tighten until after tightening the motor in the attaching strap.

(4) Tighten the blower motor mounting strap securely, making certain the air tubing is in proper alignment.

(5) Secure the air tubing by tightening the clamp or installing the sheet metal attaching screws.

(6) Connect the wire lead at the quick-disconnect terminal. Be sure to slide an insulating sleeve over the connection (or tape it) in order to prevent any possible short circuits. Tie the sleeve in place.

(7) Connect the ground lead securely to the aircraft, under one of the motor mounting screws.

(8) Check motor operation and re-install access panels. By disconnecting the wire at the No. 3 terminal on heater terminal strip, blower can be operated without fuel flow to the heater.

3.8 Spark Plug

Three types of spark plugs are used on Janitrol Aero-

Aircraft Heaters. The three types are pictured on the following pages.

Type I Spark Plug has a center electrode and an attached ground electrode bail (see Figure 3-9).

Type II Spark Plug (see Figure 3-10) has a center electrode but no attached ground electrode. The ground electrode is attached to the combustion head of the heater.

Type III Spark Plug is shown in Figure 3-12. This spark plug contains a center electrode. This spark plug is used on high altitude kerosene burning heaters.

WARNING

Failure to test the spark plug and/or the ignition assembly by one of the following three methods will result in damage to the lead assembly, coil assembly, spark plug, or vibrator. Can shorten the useful life of these items and possible shock to operator.

DO NOT ARC IGNITION LEAD TO ANY GROUND EXCEPT THROUGH APPROVED SPARK PLUG GROUND ELECTRODES. GROUNDING LEAD TO JACKET IS DANGEROUS TO OPERATOR AND THE HEATER IGNITION UNIT.

- a. Removal (See Figure 6-1 and 6-2)
 - (1) Remove the necessary access panels to expose the spark plug area of the heater assembly.

NOTE:

Insure that electrical circuits are de-energized.

- (2) Unscrew and remove the high-voltage lead connector at the spark plug. Exercise care to avoid fouling or damaging the connector.

- (3) Remove the grommet.

- (4) Using a 7/8 inch deep hex socket, unscrew and remove the spark plug (11). Make sure the spark plug gasket is removed with the spark plug. It will normally stick on the spark plug threads; but if loose, it might drop into the ventilating air passages of the heater. Should this happen, remove the gasket with a wire hook.

- b. Inspection and Servicing (Type I Spark Plug)

- (1) If the spark plug appears to be in good condition, except for a mild coating of oxide on the porcelain and electrodes, it may be cleaned and reused. Cleaning is accomplished on a conventional aircraft type spark plug cleaner, except that it will be necessary to use two or more adapters in order to raise the long extension of the plug far enough out of the cleaner nozzle opening to provide an effective job. Plug the ceramic insert cavity at the terminal-end of the plug with a piece of paper or cloth to keep out any of the cleaning sand. Wipe this cavity out thoroughly with a cloth. If, after cleaning spark plug, porcelain is then white, and the electrodes are not eroded, re-gap the spark plug by carefully bending the ground electrode until a 0.055 inch feeler gage can be inserted between the end of the center electrode and the ground electrode. (See Figure 3-9.)

- c. Installation

- (1) Installing Type I Spark Plug

If a new spark plug is being installed be sure to measure the gap which should be between 0.050 and 0.060 inches. Do not bend the center electrode.

NOTE:

If the spark plug fails to clean up properly and/or if electrodes are badly eroded, it should be replaced.

NOTE:

The spark plug can be checked visually for sparking across the gap prior to installing the plug as follows:

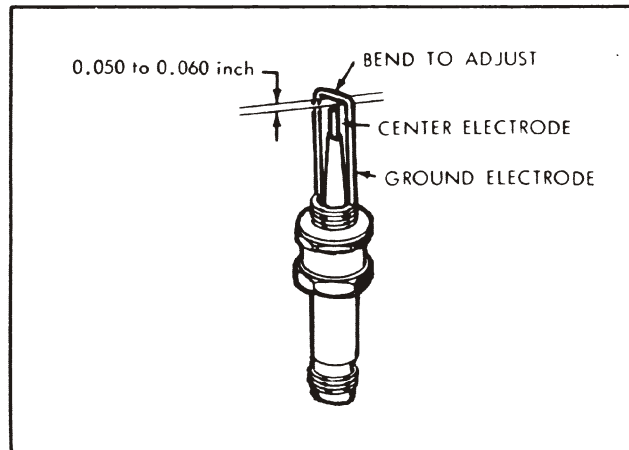

FIGURE 3-9 Type I Spark Plug

Disconnect the wire from the No. 3 terminal on the heater wiring side of the terminal strip to de-energize the fuel solenoid valve. Connect the high-voltage lead temporarily and lay the spark plug on the heater jacket. Energize heater system and check for spark between spark plug and ground electrode.

WARNING

Be sure to plug the spark plug hole in the heater to prevent any possibility of residual fuel blowing out and igniting. Do not touch the spark plug while energized because of dangerously high voltage.

- (2) Place a new spark plug gasket on the threads. If the gasket does not hold on the threads and would be likely to fall off during installation, place a small drop of Aviation Permatex, or similar material, on the gasket to stick it temporarily to the plug shell.

- (3) Screw the spark plug into the heater with a deep socket. Tighten to a torque of 28 ft. lbs.

- (4) Install the grommet in the heater jacket opening.

- (5) Carefully insert the spring connector on the high voltage lead into the spark plug shell, press down gently and start the nut on the threads. Tighten the nut to 20 ft. lbs.

- (6) Reconnect the wire to the No. 3 terminal on terminal strip, if disconnected for above tests.

- (7) Operate the heater to check dependability and close all access openings.

- d. Type II Spark Plug

- (1) Inspection and Servicing of Type II Spark Plug

This type of spark plug may be cleaned by using the same method described for Type I Spark Plug. The method for checking the spark gap is described below.

Prior to installation, the Type II spark plug can be checked visually for sparking across the gap prior to

installing the plug. The Type II Spark Plug must be installed in the special ground electrode fixture as shown in Figure 3.11. Screw spark plug into fixture until tight. Adjust rod on fixture to obtain a gap of .156-.188".

Disconnect the wire from No. 3 terminal on the heater wiring side of the terminal strip to de-energize the fuel solenoid valve. Connect the high-voltage lead temporarily and lay the spark plug in its special ground electrode fixture on the heater jacket. Energize heater system and check for spark between spark plug and ground electrode.

(2) Installing Type II Spark Plug

Prior to installing the spark plug the spark gap should be checked. The .156 to .188 in gap as shown on Figure 3-10 may be checked as follows:

- Measure the distance between the seating surface of the spark plug with a new gasket installed to the end of the plug electrode.
- Using a depth gauge, measure the distance between the ground electrode in the heater to the spark plug seating surface in the jacket and check against the measurement obtained in Step 1. The difference should be between 0.156 and 0.188 inch.
- The ground electrode can be bent to obtain the correct gap.

After the spark plug gap is checked the spark plug and gasket may be installed and torqued as described for the Type I Spark Plug.

NOTE:

If the spark plug fails to clean up properly and/or if electrodes are badly eroded, it should be replaced.

e. Type III Spark Plug

(1) Inspection and Servicing of Type III Spark Plug
If the spark plug appears to be in good condition the outer surface of the ground electrode sleeve may be wiped clean with a rag, the internal porcelain may be blown clean using shop air directed through the vent holes or through the open end. After cleaning the spark gap may be checked. The gap between the center electrode disk and the ground electrode should be between .156 and .188 inch. See Figure 3-12.

NOTE:

NO RE-GAPPING OF THIS TYPE SPARK PLUG IS POSSIBLE – DO NOT BEND THE CENTER ELECTRODE OR THE DISK ON TOP OF THE CENTER ELECTRODE.

(2) Checking Spark

Prior to installation, spark plugs can be checked visually for sparking across the gap prior to installing the plug as follows:

Disconnect the wire from the No. 3 terminal on the heater wiring side of the terminal strip to de-energize the fuel solenoid valve. Connect the high-voltage lead temporarily and lay the spark plug on the heater jacket. Energize heater system and observe spark between center electrode and ground electrode.

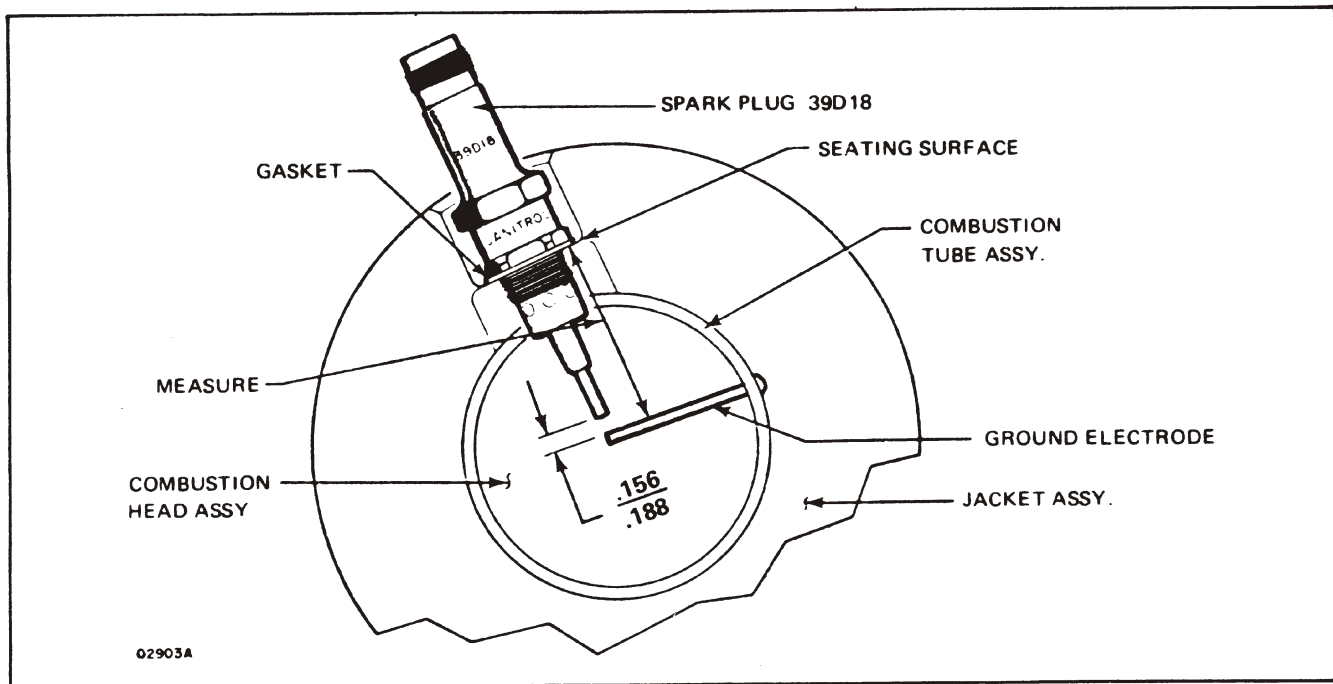

FIGURE 3-10 Type II Spark Plug As Installed In Typical Heater Assembly

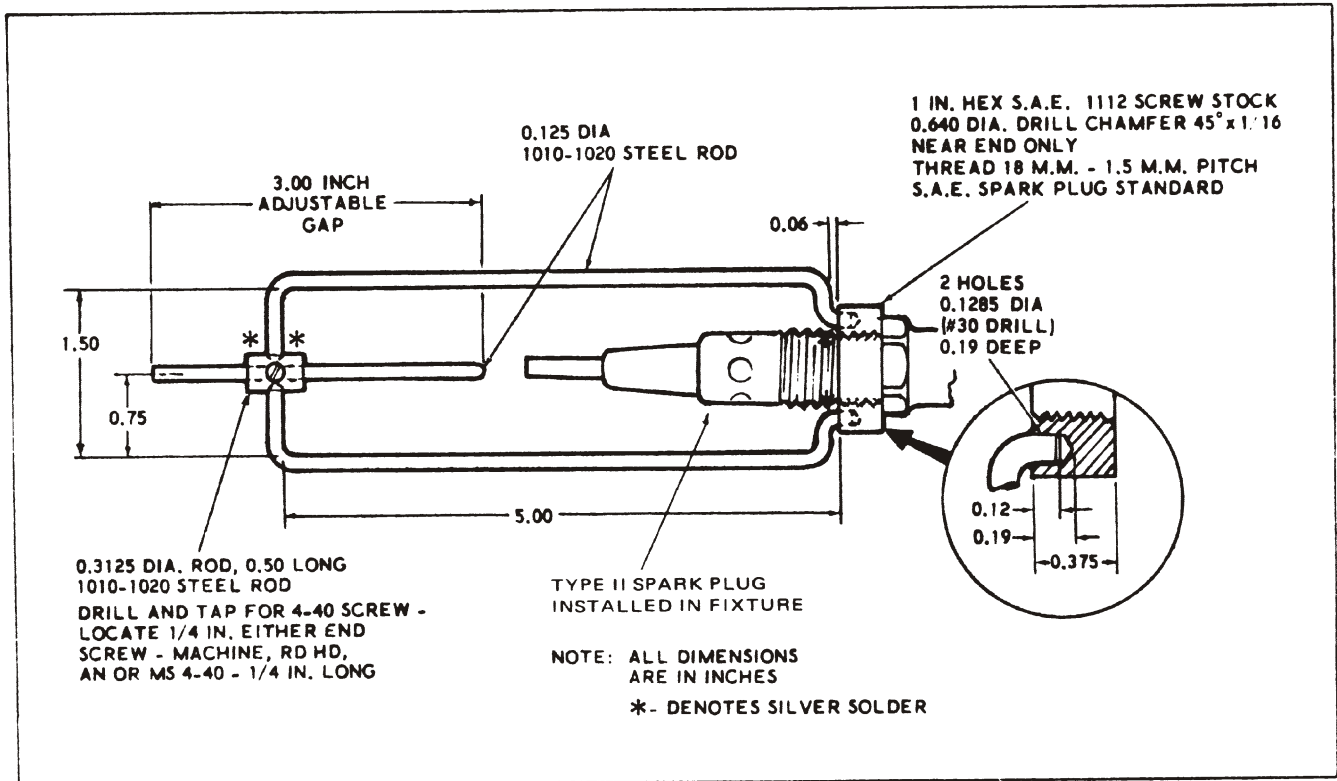

FIGURE 3-11 Special Ground Electrode Fixture

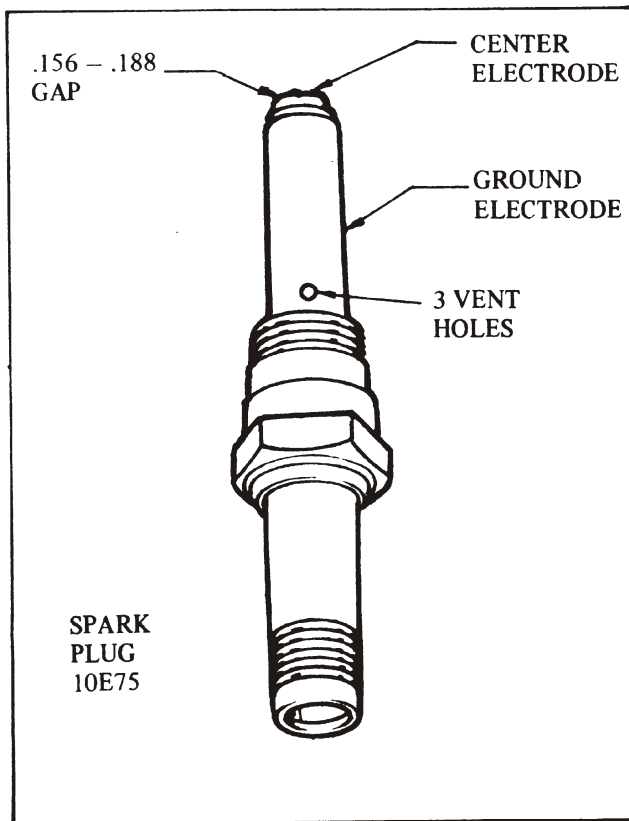

FIGURE 3-12 Type III Spark Plug

(3) Installation of Type III Spark Plug

If installing a new spark plug, check for correct gap at the electrode. The gap should be .156 to .188 inch.

The spark plug may be installed the same method as described for the Type I Spark Plug.

NOTE:

If the spark plug fails to clean up properly and/or if electrodes are badly eroded, it should be replaced.

3.9 Vibrator Assembly

(See Figure 6-1) (Part No. 08D50 Series Ignition Unit)

- a. Remove the necessary access panels to reach the ignition unit on the heater assembly.
- b. Measure the distance the vibrator protrudes out of the ignition assembly to determine when the new unit is inserted properly. Grasp the vibrator (8, Figure 6-1) and with a slight back and forth movement, pull it straight out of the ignition unit. (For a friction grip, it may be necessary to use a piece of masking or friction tape around the exposed portion of vibrator.)
- c. Carefully rotate the new vibrator until the index marks are aligned and the connector pins on the vibrator can be felt entering the pin sockets in the vibrator socket, then press the vibrator fully and firmly into position.

d. Check the heater for operation and close all access openings.

3.10 Ignition Assembly

a. Removal

(See Figure 6-1, Ref. 08D50 Series Ignition)

(See Figure 6-2, Ref. 87D12, 87D24, 92D12, 92D24, 17E24, 90E12, 91E12, 91E24 Ignition Assemblies)

(1) Remove access panels necessary to reach the ignition assembly (8), Figure 6-1.

NOTE

Make sure heater electrical circuits are de-energized.

(2) Disconnect the primary wire (4) from the primary terminal of the ignition assembly (8).

(3) Carefully unscrew and disconnect the high-voltage ignition cable at the spark plug. Exercise care to avoid fouling or damaging the connector. (Refer to Paragraph 3.8, a.)

(4) Remove the four attaching screws (9) and lockwashers (10) and lift the ignition assembly (8) off the mounting brackets on the heater jacket.

b. Installation (See Figure 6-1 and 6-2)

(1) Place the ignition assembly in position on the brackets attached to the heater jacket, with the high-voltage cable facing the spark plug end of the heater.

(2) Install the four screws (9) and lockwashers (10). Tighten the screws securely.

(3) Carefully connect the high-voltage lead to the spark plug. (Refer to Paragraph 3.8, c.) Properly route high-voltage cable so as to avoid grounding to power input connection and/or any other sheet metal parts of heater.

(4) Connect the primary lead (4) to the primary terminal on the ignition unit (8) and tighten the nut securely.

(5) Check for proper heater operation and install access panels.

b. Repairs

Refer to Paragraphs 4.3, 4.5, 4.8 and 4.13 for overhaul instructions covering the fuel pump.

c. Installation

(1) Attach the fuel pump to the aircraft structure member with the two attaching bolts. The radio-noise filter bracket must be attached with one of these bolts. Make sure a good electrical ground is present and proper polarity connection made.

(2) Connect the inlet and outlet fuel lines and tighten them securely.

(3) Connect the electrical lead at the radio-noise filter connection. Be sure the insulator is in place and the connector is locked securely.

(4) Run the pump for a few minutes to check for fuel leaks.

(5) Install access panels.

3.12 Cycling Switch and Limit (Overheat) Switch (See Figure 6-1)

a. Removal

(1) Remove access panels to provide access to the heater.

(2) If the limit switch (16, Figure 6-1) is damaged or defective, disconnect the three electrical leads from the switch terminals. Be sure to mark the leads for proper re-assembly. (The switch terminals are identified by numbers 1, 2 and 3.)

(3) Remove the two attaching screws (17), lockwashers (18) and plain washers (19) and lift the limit switch (16) and spacers (gaskets) (20) from the jacket opening.

(4) If the cycling switch (21) is damaged or defective, disconnect the electrical leads, being sure to mark them for proper re-assembly.

(5) Remove the two screws (22), lockwashers (23) and plain washers (24) and lift the cycling switch (21) from the jacket opening.

NOTE:

No attempt should be made to repair either of these switches, if they do not operate properly they should be replaced. (Refer to Paragraph 5.4, l and m, for test instructions.)

b. Installation (See Figure 6-1)

(1) Install the limit switch (16) and spacer (gaskets) (20), by placing them in position in the heater jacket opening and installing two screws (17), lockwashers (18) and plain washers (19).

(2) Tighten screws securely, then reconnect the electrical leads in accordance with markings made during disassembly. (If electrical connections are uncertain, refer to the wiring diagram, Figure 2-9.)

3.11 Fuel Pump

a. Removal

(1) Remove access panels required to reach the fuel pump assembly.

(2) Shut off the fuel supply to the pump; disconnect electrical lead and fuel lines. Exercise care to avoid losing the insulator in the electrical connector. Unless the fuel lines are rigid enough to remain in their original locations, be sure to tag them for proper connection during re-installation.

(3) Remove the attaching bolts from the fuel pump bracket and remove the fuel pump from the aircraft.

(3) Install the cycling switch (21) by placing it in position in the heater jacket opening and securing it with the two screws (22), lockwashers (23) and plain washers (24). Tighten screws securely, then reconnect the electrical leads to their respective terminals as marked during disassembly. (If connections are uncertain, refer to wiring diagram, Figure 2-9.)

3.13 Combustion Air Pressure Switch (See Figure 6-1 and 6-2)

a. Removal

(1) Remove access panels to expose the heater assembly.

(2) Disconnect electrical leads from the terminals of the combustion air pressure switch (31), being sure to mark them for proper reassembly. (On any installation where this is used as a differential pressure switch, the tube will have to be disconnected from the switch cap. Exercise caution not to exert excessive bending of the tube. It is "tacked" to the combustion chamber inside the jacket.)

(3) Unscrew and remove the combustion air pressure switch from the fitting on the combustion air inlet tube.

b. Installation

(1) Install the combustion air pressure switch (31) by rotating it on the threaded fitting of the combustion air inlet tube and tighten it securely. Exercise caution not to over torque the switch as this could change the setting.

(2) Connect electrical leads to their respective terminals in accordance with markings made during removal. If in doubt, regarding proper connections, refer to the wiring diagram, Figure 3-7. (If the switch is used as a differential pressure switch connect the tube to the switch cap.)

(3) Check for proper heater operation and install access covers.

3.14 Fuel Regulator and Shutoff Valve

a. Removal

(1) Remove access panels necessary to reach the fuel regulator and shutoff valve.

(2) Disconnect the electrical lead from the valve.

(3) Disconnect the fuel lines from the inlet and the outlet openings. Take note of these connections for correct installation.

(4) Remove the two attaching screws to free the unit from its mounting.

b. Installation

(1) Attach the fuel regulator and shutoff valve to its mounting with the two attaching screws. If the fuel regulator and shutoff valve is being mounted in the fuselage, it must be shrouded to protect against the possibility of fuel leakage.

(2) Place the fuel regulator and shutoff valve into position between the fuel line connections and install and tighten connections securely.

(3) Connect the electrical lead. Be sure to slide an insulating sleeve (or tape) over the connection to avoid a short circuit and tie the sleeve in place.

(4) Operate the heater to make sure the unit is functioning properly and re-install access panels.

3.15 Duct Switch (See Figure 2-6-1 and 2-6-2)

a. Removal

(1) Place the control lever arm at the "H" position and loosen the screw holding the through control wire and slide the control wire out of the lever arm.

(2) Disconnect the two electrical leads from the terminals on the exposed face of the switch.

(3) Remove the two attaching screws and washers from the duct.

(4) Carefully lift out the duct switch, with gasket (if gasket is used).

b. Cleaning and Inspection

Brush off any dust or lint from the switch operating mechanism (exposed inside the duct) and wipe off external surfaces with a clean cloth.

c. Installation

(1) Insert the switch carefully, with gasket (if used), into the ventilating duct opening and install the two attaching screws and washers.

(2) Connect the two electrical leads to their respective terminals, as marked during removal.

(3) Set the temperature selector shaft at the high stop, then carefully place the temperature control in the aircraft cabin to the high heat position. Reinstall control wire into control lever arm and tighten screw.

(4) Operate the heater with the duct switch set above ambient temperature to check operation. (Refer to Paragraph 5.4,1, for additional switch tests and setting instructions.)

SECTION IV - OVERHAUL INSTRUCTIONS

The heater assembly shall be overhauled after 1000 hours or when the Pressure Decay Test requirements cannot be met. The heater should be removed from the aircraft in accordance with the aircraft manufacturers maintenance manual, disassembled, all parts thoroughly inspected and necessary repairs and replacements made prior to reassembly. Detailed step-by-step instructions are included for a complete heater overhaul. In some instances, however, inspections may reveal that it is unnecessary to remove certain parts, and if so, those portions of the overhaul procedures may be eliminated.

NOTE:

For general disassembly and reassembly operations refer to the exploded view drawings in Section VI. However, for the detailed breakdown of parts for your particular heater assembly see your aircraft owners manual or your local aircraft dealers parts department.

4.1 Disassembly (See Figure 6-1 and 6-2)

Refer to the aircraft manufacturers maintenance manual.

NOTE:

Since all heater models are covered in the general exploded view illustration (Figure 6-1 and 6-2), it will be found that certain parts are not used on all models. Be sure to refer to the parts list for the particular heater part number you are overhauling. The parts list for heaters is covered in the aircraft maintenance manual or at your aircraft dealers parts department.

- a. Remove the screw (3) and slide the elbow adapter (2) off the combustion air inlet tube. If the straight adapter (2a) is used, it is removed in the same manner.
- b. Disconnect and remove electrical wiring (6) and individual wires from the various components on the heater. If wires appear to be in good condition, it may be desirable to remove wire harness assembly intact. First, disconnect wires at terminal strip and components. On some models, the ventilating air blower housing must be removed so that the two motor wires and solenoid valve quick-disconnect connections may be released.

NOTE:

It is advisable to label all wires, prior to removal, to insure correct connections during re-assembly. Cable straps and clips must be replaced if removed, as they cannot be re-used.

c. Carefully disconnect the high-voltage ignition lead at the spark plug. Handle the spring connector on the end of this lead with care to prevent fouling or damage.

d. Remove the four screws (9), lockwashers (10) and cable straps (7), to free the ignition assembly (8) from the heater jacket and remove the ignition assembly. The vibrator may be removed by exerting a firm pull straight away from the ignition assembly case. (Refer to Paragraph 3.9, b.)

e. Remove the two screws (14) and lockwashers (15) to release the radio-noise filter (13) from the jacket (70).

f. Remove the grommet (12) from the jacket (70) and remove the spark plug (11) with a 7/8 inch deep socket. Make sure the spark plug gasket is removed.

g. Remove the two screws (17), lockwashers (18) and flat washers (19) and lift out the overheat (limit) switch (16) and spacer gaskets (20).

h. Remove the two screws (22), lockwashers (23) and flat washers (24) and lift out the cycling switch (21).

i. Remove the four screws (26) and lockwashers (27) to release the terminal strip (25) and insulator (28) from the jacket (70).

j. Disconnect the tube fitting (30) at the cover of the combustion air pressure switch (31). (Refer to Para. 3.13, a (2) for precaution on tube bending.) Unscrew and remove the combustion air pressure switch (31) from the combustion air inlet tube.

k. If the heater is equipped with an adapter and screen assembly (38), remove it from the blower housing (48) by removing the three screws (39) and lockwashers (40).

l. Loosen the four screws (37) and rotate the blower and motor housing (48) to disengage the notched end from the four screws in the end of the heater jacket. Remove the grommet (36) and separate the two electrical quick-disconnects after sliding back the insulator sleeves on the wire ends (56).

m. Reach inside the inlet end of the jacket assembly (70) with a 3/4 inch open-end wrench and, while holding the fuel-tube fitting at the jacket, remove the reducing bushing adapter (32), if used. Then with 3/4 inch deep socket, remove the nut (34), fuel fitting shroud (33) and gasket (35).

n. Remove the two screws (58) and lockwashers (59) and carefully withdraw the nozzle holder and valve

assembly from the combustion tube assembly (76). Remove the gasket (68).

o. Remove the screws (71, 72, and 73), lockwashers (74) and remaining cable straps (7), if not previously removed, from the seam of the jacket assembly (70). Note positions of cable straps as they are removed. Spread the jacket (70) at the seam and remove it from the combustion tube assembly (76). This will free the rope gasket (75) which can be removed from the particular part on which it remains attached.

p. Carefully unscrew and remove the spray nozzle (69) from the nozzle holder and solenoid valve assembly. Remove "O" ring (67).

CAUTION:

Handle the nozzle with care to avoid damage to the tip. The material around the orifice is very thin and any sharp blow on the face of the nozzle can distort the spray pattern and cause malignition or improper combustion.

q. Remove the screw (61), lockwasher (62), cover (60) and "O" ring (63). Then carefully slide the solenoid coil (64) off the valve assembly. It is not necessary to remove the base plate (65) unless it is warped.

r. Loosen the nut (43) and remove the screw (41), flat washer (44) and rubber grommet (47).

s. Remove the two screws (42), flat washers (44) and rubber grommets (47) at the other two locations around the blower motor housing (48).

t. Slide the ventilating air blower motor (55) out of the blower housing (48) with the motor bracket assembly (57) and blower wheel (49) attached. Loosen the set screw in the blower wheel (49) and slide it off the end of the motor shaft. The flat washers (45) and rubber washers (46) will fall out when the bracket is removed. Then remove the motor bracket assembly (57). If these parts are in good condition, they need not be disassembled further.

u. Remove the screw (51) and lockwasher (52), to free the capacitor assembly (50) with attached leads.

4.2 Disassembly of Combustion Air Blower Assembly (See Figure 6-4)

a. Remove the combustion air blower inlet adapter (29) (if used) by removing three screws (26), lockwashers (27), cover plate (25) and gasket (28). This will also free the inlet flange (4).

b. Remove the outlet adapter (1) by removing the two screws (2) and lockwashers (3).

c. Remove the inlet flange (4) by removing the three screws (5) and lockwashers (6), if not removed in preceding step a.

d. Remove screws (10 and 14) and lockwashers (11 and 15), then separate the back plate (17), with

motor (23) attached, from the blower housing (13) and free the motor leads and capacitor (9) from the back plate (17).

e. Loosen the set screw in the blower wheel (16) and slide it off the motor shaft.

f. Remove the two hex nuts (18), lockwashers (19) and flat washers (20), and slide the back plate (17) off the motor through bolts. The spacer (22) will drop out.

g. Install new motor brushes as described in Para. 3.7, b. If the motor commutator is badly worn, or if the motor is defective in any respect, it must be replaced.

4.3 Disassembly of Fuel Pump (See Figure 4-1)

(1) The interrupter end of the fuel pump is sealed, with air removed and an atmosphere of a special dry gas injected. Should any of the electrical components become inoperative, the fuel pump must be replaced. The gas seal is located in the center of the mounting bracket and no attempt should be made to break this seal, as it would render the pump useless.

a. Hold the pump body securely in one hand and release the bottom cover (1) from the bayonet fittings by rotating it counter-clockwise with a 5/8 inch, open-end wrench or box socket.

b. Remove the gasket (2) from the cover (1).

c. Carefully remove the filter screen (3).

d. Remove the three screws (4), that hold the plunger spring cup (5) to the pump body (9).

e. Remove the gasket (6) and plunger spring (7).

f. Carefully withdraw the plunger (8) from the pump body (9). Do not drop or mutilate the plunger.

4.4 Cleaning Procedures

a. Clean individual metal parts (except those parts containing switches and electrical wiring) and the combustion tube assembly (76, Figure 6-1) by immersing them in dry-cleaning solvent, such as Stoddard solvent (Federal Specification P-S-661). A bristle brush should be used to assist the cleaning process if foreign accumulations are stubborn to remove.

CAUTION:

Do not attempt to buff or scrape off any deposits on face of spray nozzle. The face of the nozzle is very susceptible to damage from mishandling. Carefully repeat cleaning process using only a bristle brush and repeated applications of solvent to loosen any stubborn deposits.

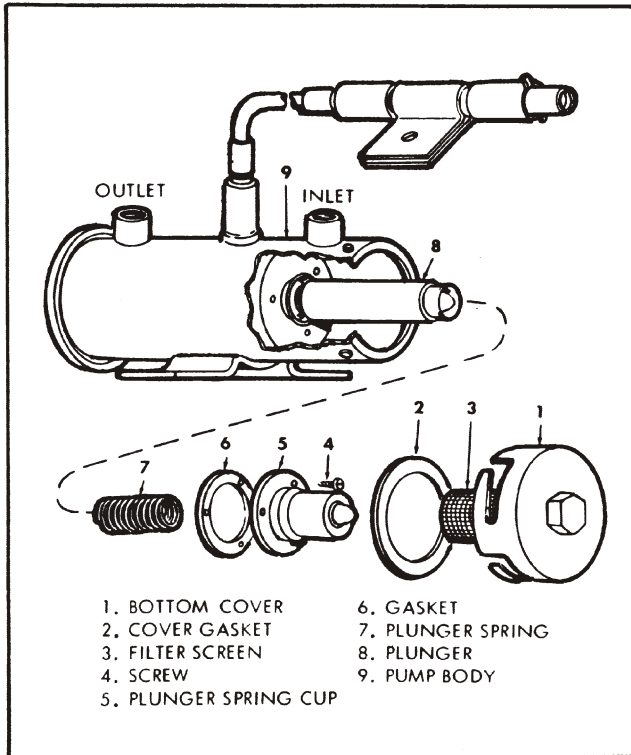

FIGURE 4-1 Exploded View of Electric Fuel Pump

- b. Use compressed air or lintless cloth to dry the parts, unless sufficient time is available for them to air dry.
- c. Wipe electrical components with a clean, dry cloth. If foreign material is difficult to remove, moisten the cloth in electrical contact cleaner and clean all exterior surface thoroughly.

4.5 Cleaning Fuel Pump Parts (See Figure 4-1)

- a. Wash the plunger assembly in Stoddard Solvent or gasoline. If it fails to become thoroughly clean or if any rough spots are present, dress the surface carefully with crocus cloth. Rinse thoroughly to remove all foreign material.
- b. Dip the pump body in clean solvent, shake it lightly, then remove it and dry with compressed air.
- c. Blow out the plunger tube with compressed air and check for any rough spots or deposits or foreign material. If not smooth, wrap a piece of cloth around a wood dowel, dip the cloth in Stoddard Solvent (Federal Specification P-S-661), and swab the plunger tube until clean.
- d. Rinse remaining parts in the solvent and dry with compressed air. Exercise care when drying the screen (3), to prevent damage.

4.6 Cleaning and Inspection of The Combustion Tube Assembly (See Figure 6-1 and 6-2)

- a. Slight scaling and discoloration of the combustion tube assembly (76, Figure 6-1) is a normal condition for units that have been in service up to 500 hours. The slight scaling condition will appear to be mottled and a small accumulation of blue-gray powder may be present on the surface in certain areas. This condition does not require replacement of the combustion tube assembly, unless severe overheating has produced soft spots in the metal.

NOTE:

This assembly should be inspected prior to cleaning in order to prevent the removal of visible evidences of damage.

- b. Look inside the exhaust outlet to determine if the combustion tube appears to be heavily scaled or mottled. Deformation is more difficult to detect visually but can usually be observed by looking straight through the combustion tube assembly and sighting along the outer surface of the inner combustion tube. An assembly that has been obviously deformed, should be replaced. Slight deformation will not affect heater operation unless it is extensive and localized enough to reduce the flow of ventilating air through the heater more than ten percent. Inspect the sensing tube for clogging. If it is clogged, it must be cleaned. Disconnect at switch and clear tube by blowing air through it. If combustion product residue has collected in the exhaust end of the tube, it may be necessary to clear tube with a wire.

- c. The combustion tube assembly may be cleaned by either of two methods:

(1) One method is to soak the combustion tube assembly overnight in a solution of Kelite No. L235 cleaning solution. Should be 1 to 12 parts by volume. The solution should be maintained at a temperature of between 190°F and 210°F. After overnight soaking, rinse the combustion tube assembly thoroughly in water, to remove all traces of the Kelite solution. In order to reach all areas of the combustion tube assembly, it is advisable to let it stand in the rinsing water for as much as 1/2 hour, while occasionally agitating it to circulate the water. All openings should be left open during this operation. Be sure to dry the combustion tube assembly thoroughly after cleaning by blowing with air.

(2) A second method of cleaning is what is commonly known as hand "tumbling." Insert shot or glass beads through the exhaust outlet opening, then close all openings and shake the combustion tube assembly vigorously, while rotating it and changing from end-to-end frequently. Be sure to

pour out all of the particles and loosened material, then with all openings uncovered, direct a stream of compressed air into the combustion tube assembly from first one opening, then the other. Make sure all loose material is removed.

4.7 Inspection of Remaining Components (See Figure 6-1)

- a. Discard all rubber parts, such as grommets, gaskets, etc. These items should always be replaced at overhaul. Also discard the rope gasket (75).
- b. Inspect all wires and wiring harnesses for damage to insulation, damaged terminals, chaffed or cracked insulation and broken plastic bands. Individual wires can be replaced by making up new wires from No. 16 AWG stock and cut to correct length. It is advisable to use an acceptable crimping tool for installing terminals, rather than solder, for all heater wiring connections. If wiring harness damage is visible, the entire harness assembly should be replaced. If only one or more wires are damaged, cut the cable ties, make up new wires, install them in the harness, and restore all cable ties and clamps. If heater controls were operating properly at the time of removal, re-install them.
- c. Inspect all hardware parts, consisting of bolts screws, nuts, washers, and lockwashers. Replace damaged parts.
- d. The combustion air pressure switch (31) must respond to delicate pressure changes and should always be checked and/or replaced at overhaul. Refer to Paragraph 4.9, c and Figure 4-3.
- e. Replace the vibrator in the ignition unit at each overhaul.

CAUTION:

Ignition assembly will be damaged if ignition lead is arced to ground other than through correct spark plug gap. Vibrator life will be substantially reduced if ignition lead is improperly grounded. See Paragraph 3.8 on correct spark plug gapping.

- f. Inspect the ignition assembly (8) for dented case, loose or damaged primary terminal insulator and broken or obviously damaged high-voltage lead. Give particular attention to the condition of the spring connector at the end of the lead. If the spring is burned off, visibly eroded or carbon tracked, the ignition assembly should be replaced.

NOTE:

Do not attempt a field repair of the ignition unit, Part No. 08D50.

- g. Inspect the terminal strip (25) for distortion and cracks and replace it if either condition exists.
- h. Inspect all radio-noise filters for short circuits by

checking from either terminal to ground with an ohmmeter. An open-circuit reading should be obtained.

- i. Inspect the spray nozzle (69 on Figure 6-1 and 38 on Figure 6-2) with a magnifying glass for any obstructions in the nozzle orifice and any sign of damage to the slight conical protrusion at the nozzle tip. Use compressed air to remove obstructions and re-examine it to make sure the orifice is open. Exercise care when handling the nozzle to avoid pressing or rapping on the tip face. Do not buff or scrape off deposits on the tip face. After cleaning, it is advisable to store the nozzle in a polyethylene bag until ready for re-assembly.

NOTE:

The nozzle (69 and 38) can be spray tested by installing it in the holder and connecting the fuel tube to a 7.5 psi fuel pressure source for aviation gasoline or 100 psi source for kerosene. Connect the solenoid leads to a 12-volt or 24-volt current source (battery), as required to open the solenoid valve. The conical angle spray pattern should be even and dispersed the same in all directions, divergence spray shall have appearance of fog, not droplets. Exercise caution to keep atomized fuel away from fire.

- k. Inspect the nozzle holder and solenoid valve assembly for damaged threads at the fuel-tube fitting, crimped or cracked fuel line or distorted housing.

There are two types of fuel shutoff solenoids. One type is mounted on the jacket of the heater and the other is mounted on the head of the heater as an integral part of the fuel nozzle holder.

For the solenoid that is mounted on the head of the heater, for a 24-volt system solenoid, the coil winding must read between 75 and 85 ohms resistance with an ohmmeter connected across the coil leads. For a 12-volt solenoid coil winding, the resistance must read between 18-22 ohms resistance.

For the type of fuel solenoids that are mounted on the heater jacket, the coil resistance for the 24-volt system must be between 82-87 ohms. The 12-volt system resistance must be 19-21 ohms. If not within these limits or if solenoid shows any form of damage or overheating (discoloration) the solenoid must be replaced.

- l. Remove the brushes from the ventilating air blower motor (11, Figure 6-3) as follows:
 - a) Remove nuts (13) and washers (14).
 - b) Remove back shell.
 - c) Remove secondary nuts and washers.
 - d) Carefully remove brush holder assembly.
 - e) Unsolder and remove brush (21) and spring (23).
 - f) Remove brush (22) and spring (23).
 - g) Remove foreign material from brush guides and commutator with a stream of filtered Compressed Air

- h) Check for brush wear (Refer to Para. 3.7)
- i) Inspect the commutator for grooved brush tracks, pitting or burning. The commutator should be smooth and medium brown in color. Replace motor if the commutator or other parts show damage. Reverse above procedure for re-assembly.
- m. Remove the brushes one at a time from motors viewed in Figures 6-4 and 6-5 by removing the brush cap and carefully withdrawing the brush from its guide. Remove foreign material from the brush guide and commutator with a stream of filtered compressed air. Check for brush wear (Refer to Para. 3.7). Inspect the commutator for grooved brush pitting or burning. The commutator surface should be smooth and medium brown in color. Replace the motor if the commutator or other parts show damage.
- n) Inspect the blower wheel (49, Figure 6-1 and, 16, Figure 6-2) for broken or bent vanes and replace it for either condition.

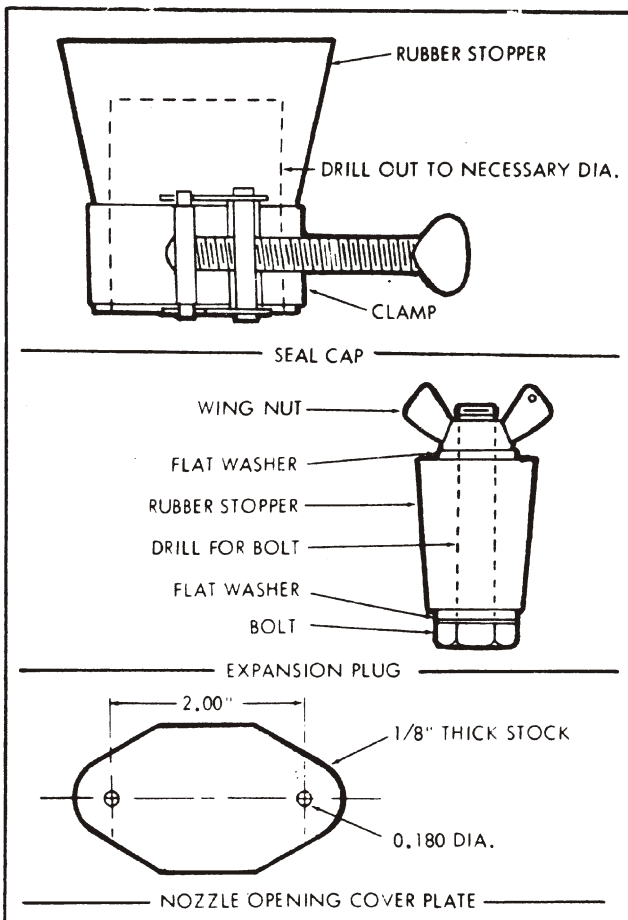

FIGURE 4-2 Suggested Design for Seal Plate, Plugs and Caps for Combustion Tube Leakage Test

4.8 Inspection of Fuel Pump Parts (See Figure 4-1)

- a. Inspect all parts visually for damage.

- b. Inspect the fuel pump electrical resistance by connecting an ohmmeter between the connector terminal and ground on the pump housing. Resistance should be between 19.0 and 30.0 ohms for 24 volt models, and 4.8 to 12.0 ohms for 12 volt models. If resistance is not within limits, replace the pump assembly.

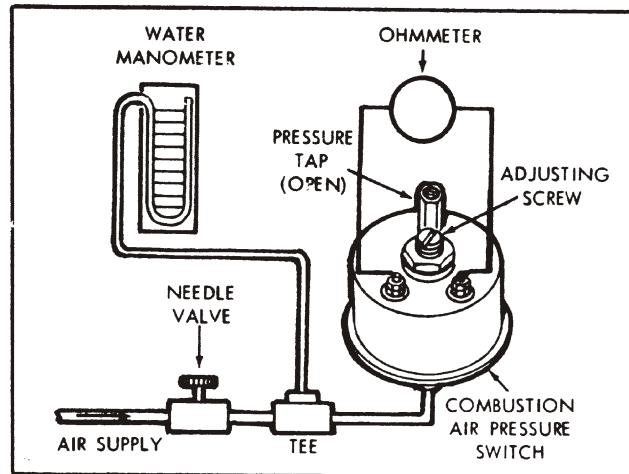

FIGURE 4-3 Test Set-Up for Combustion Air Pressure Switch

4.9 Testing of Components

The following tests should be performed as outlined in succeeding paragraphs.

- a. Test ventilating air, and combustion air motors for correct rpm and current draw:

(1) Connect motor to correct voltage power supply (12 or 24 volts DC). Rotation should be counter-clockwise when viewed from the shaft end.

(2) Both motors should rotate at approximately 7500 rpm at rated voltage. Current draw for 12-volt motors is approximately five amperes and for 24-volt motors is approximately 2.9 amperes.

(3) If current draw is excessive, or if speed is too low, replace the brushes. Recheck both current draw and rpm after brushes are properly run-in. (Refer to Paragraph 3.7, b.)

(4) If after replacing brushes, operation is still unsatisfactory, replace the motor.

The motor checks described above should be made without the blower housing attached, for both the ventilating air and combustion air motors.

- b. Test the combustion tube assembly (76, Figure 6-1) for leaks as follows:

(1) Fashion a sealing plate from approximately 1/8 inch thick flat stock to seal the nozzle holder opening in the combustion tube assembly. (See

Figure 4-2). Use a rubber gasket under the plate and attach the plate with two screws.

(2) Make up seals for all remaining openings, except the one used to connect the air pressure source. (See Figure 4-2.) Use rubber stoppers as shown. The combustion air inlet tube can be sealed best with a drilled stopper and clamp. Other openings should be sealed with expansion plugs. The seal used in the exhaust tube should be formed so that it will not deform the air pressure switch tube which protrudes into the exhaust.

(3) Install plugs and caps in all openings except the one to which the combustion air pressure switch is attached. (Any opening can be used to connect the air pressure source, however, the combustion air pressure switch opening is usually the most convenient. The drain opening would normally be considered a second choice.)

(4) Connect a regulated air supply to the opening that has not been plugged and apply a pressure of between three and seven psi to the combustion tube assembly.

NOTE

The Inspection Pressure Decay Test cannot be used in place of the water tank inspection. No weld or braze repair of combustion tube assembly is authorized.

(5) Submerge the combustion tube assembly in water for several minutes while watching for bubbles, which would indicate leaks. No air leakage is permitted from the combustion tube assembly. No weld or braze repairs are permitted on a combustion tube assembly.

c. Test the combustion air pressure switch as follows:

(1) Connect an adjustable air pressure line that can be controlled in a range of zero to 5.0 (maximum of water to the switch opening with a water manometer and needle valve in the line ahead of switch.) Switch must be tested in 45 degree position as shown in Figure 4-3, or as mounted on Heater as in aircraft.

(2) Connect an ohmmeter across the switch terminals to determine the exact instant of switch closing.

(3) Apply air pressure allowing it to build up very slowly from zero. The switch contacts should close at 0.5±0.1 inches of water which will be indicated on the manometer.

NOTE:

The switch cover has a differential pressure tap and this opening must be left open to atmosphere during the test.

(4) Make several trials to insure switch reliability. Be sure to increase and decrease the air pressure slowly in order to produce accurate indications.

(5) If an adjustment is required, rotate the adjusting screw clockwise to increase settings and

counter-clockwise to decrease settings. Replace switch if erratic operations, sticking, etc., is observed.

d. Test the fuel feed and nozzle holder assembly for leaks as follows: This test can be simplified if the following routine is used to test both the fuel line and fuel line shroud tube.

(1) Using filtered compressed air, apply 20 psi to the shroud drain port, located on the surface near the threaded nozzle cavity.

(2) Immerse the fuel feed and nozzle holder assembly in clean water with the fuel inlet and nozzle cavity left open.

(3) Observe for bubbles which would indicate leakage. If bubbles appear at either fuel fitting, there is a leak in the fuel tube. If bubbles appear externally on the shroud tube, or at either end of the shroud tube juncture, the shroud tube is leaking.

(4) In either of the above cases, the complete fuel feed and nozzle holder assembly must be replaced.

e. Test the spray nozzle (69, Figure 6-1; 38, Figure 6-2) as follows:

(1) Install the nozzle in the fuel feed and nozzle holder assembly and connect the fuel tube to a 7.5 psi fuel pressure source for aviation gasoline heaters and 100 psi source for kerosene heaters.

(2) Connect the solenoid leads to a 12-volt or 24-volt battery (as required). Connect a switch in the line to open and close the solenoid when desired.

(3) With the switch closed (solenoid valve energized) and the fuel line connected, observe the fuel spray pattern. It should be conical in shape with even dispersion in all directions.

WARNING

Be sure to keep the atomized spray away from fire.

(4) Energize and de-energize the solenoid several times. The spray should shut off permanently each time the solenoid is de-energized. There should be no sign of dribbling at the nozzle tip, in excess of one or two drops.

(5) If the spray pattern is distorted, check for an obstruction and clean the nozzle as described in Paragraph 4.7, i. If this fails to provide a normal spray pattern, replace the nozzle.

(6) If the nozzle continues to dribble, the solenoid valve is not closing properly and the fuel feed and nozzle holder assembly must be replaced.

4.10 Repair of Combustion Tube Assembly

No weld or braze repairs are authorized.

4.11 Reassembly (See Figure 6-1)

a. If removed during disassembly, slide the solenoid coil (64) on the stem of the nozzle holder and sole-

noid valve assembly. Install the "O" ring (63), cover (60), screw (61) and lockwasher (62), then tighten the screw securely. Be careful to avoid pinching the wire leads connected to the solenoid core.

b. Insert the ventilating air motor (55) into the motor bracket assembly (57), slide the blower wheel (49) on the end of motor shaft and rotate it until the set screw is aligned with the flat side of the motor shaft. Tighten the set screw just tight enough to hold it at this time.

c. Attach the capacitor and leads assembly (50) to the motor bracket (57) with the screw (51) and lockwasher (52). Make sure a good electrical ground connection is made at this point.

d. Insert this assembly into the blower housing (48) and position it so the long screw (41) is in alignment with the gap on the inner ring of the motor bracket assembly (57). This is the screw used to secure and align the motor in the bracket.

e. Slide the flat washer (45) and rubber washer (46) into position between the legs of the motor bracket (57) and blower housing (48).

f. Make sure all four wires are routed and grommets as they were prior to disassembly and install the two screws (42), flat washers (44) and new grommets (47) at the two lower edges securing the motor bracket assembly (57). Then install the grommet (47), flat washer (44), nut (43) and screw (41) in the remaining upper corner of the motor bracket assembly (57).

g. Center the motor bracket (57) in the housing and tighten the screw (41) to secure it. The motor (55) should be positioned in the bracket (57) to locate the blower wheel (49) properly in the blower housing (48). The blower wheel should be positioned so it will rotate freely and just clear the contoured spill plate in the blower housing. Tighten the Allen-head set screw, and spin the blower wheel by hand for a clearance check. Then apply appropriate voltage to run the motor as a final clearance check.

h. Attach the adapter and screen assembly (38) (if used) to the end of blower housing (48) with three screws (39) and lockwashers (40).

i. Place a new rope gasket (75) in position on the exhaust outlet, spring the jacket assembly (70) open at the seam and insert the combustion tube assembly (76) carefully into the jacket. Exercise care to clear the pressure switch tube in the exhaust outlet and see that the rope gasket (75) is properly located. Close the gap on the jacket assembly (70) and install screws (71, 72 and 73) and lockwashers (74) to secure it at the seam. (Two leads ground under these screws. See notations made during disassembly.) Make sure the tongue and channel at the seam are in good condition and a tight fit is effected.

j. Install cable straps at locations noted during disassembly.

k. Remove the spray nozzle (69) from the polyethylene bag, and install "O" ring (67). Screw the

nozzle into nozzle holder and tighten to 75 to 100 inch-pounds. It is very important to torque the nozzle to this value as incorrect tightening could cause improper heater operation "drool," or loosening of internal body assembly of nozzle.

CAUTION

The spray nozzle has a slight protrusion on the nozzle face, if this area has been struck by any object which would make a dent or destroy the original contour, the nozzle must be replaced. It can be disassembled for cleaning in Stoddard Solvent or Ultrasonic Cleaning. **DO NOT INTERCHANGE NOZZLE PARTS.**

l. Insert the fitting on end of nozzle fuel tube through the opening in jacket (70) and attach the nozzle holder to the combustion tube assembly (76) with the two screws (58) and lockwashers (59). It may be necessary to place a slight bend in the shrouded fuel tube to permit alignment of screw holes. Be sure to use a new gasket (68) and connect the solenoid ground wire under one of these screws. Make sure a good electrical ground connection exists at this point.

m. Using a new spark plug gasket, install the spark plug (11) and tighten to a torque of 28 pounds-feet. Install the grommet (12) in the jacket around the spark plug.

n. Install the ignition assembly (8) on the jacket assembly (70) with the four screws (9) and lockwashers (10). Connect the high-voltage lead to the spark plug and tighten it to 20 pounds-feet.

o. Attach the radio-noise filter (13, Figure 6-1), not used on new ignition box (14, Figure 6-2), to the jacket assembly (70) with the two screws (14) and lockwashers (15).

p. Attach the overheat limit switch (16) and spacer gaskets (20) to the jacket assembly (70) with the two screws (17), lockwashers (18) and flat washers (19). Tighten the screws securely. (Sealed on some heaters.) After installing overheat limit switch (16) and cycling switch (21), visually check to make sure that switch does not come in contact with outer radiator.

q. Attach the cycling switch (21) to the jacket assembly (70) with the two screws (22), lockwashers (23) and flat washers (24). (Sealed on some heaters.)

r. Place the terminal strip insulator (28) in position on the jacket (70), followed by the terminal strip (25). Secure both parts by installing the two screws (26) and lockwashers (27). The two screws are located at two diagonal corners of the terminal strip.

s. Center the fuel fitting in jacket opening. Place the fuel fitting shroud gasket (35) and shroud (33) on the fuel fitting, and install the nut (34) finger tight. Insert a 3/4 inch open-end wrench inside the jacket and hold the fuel-tube fitting while tightening the nut (34) with a 3/4 inch deep socket. Install the reducer fitting (32), if used.

- t. Rotate the combustion air switch (31) onto the threaded fitting on the combustion air tube and tighten it firmly.
- u. Slide the grommet (36) over the combustion air tube and connect the tube to the elbow fitting (30) on the combustion air pressure switch (31). Grommet can be split for easier installation.
- v. Install the wiring harness (6) and connect all wire leads to their respective terminals. (Refer to the wiring diagram, Figure 2-6.) Place the grommet (36, Figure 6-1) in position in the jacket (70), locate the ventilating air housing (48) at the end of the jacket. Thread the quick disconnect on the wiring harness (see Figure 6-1) through the grommet (36) and connect it to the mating connector on the motor lead.
- w. Place the blower housing in position on the jacket assembly (70) and secure it by installing the four screws (37), if removed at disassembly. This operation is easier if the screws (37) are started into their threads and the blower housing rotated into place, allowing the screws to enter the notched openings in edge of blower housing. Tighten all screws securely.
- x. Install the elbow adapter (2), or the straight adapter (2a), as used on the particular heater involved, with the screw (3).

4.12 Reassembly of Combustion Air Blower Assembly (See Figure 6-4)

- a. Place the spacer (22) over the end of the motor shaft and attach the motor assembly (23) to the back plate (17) with the two self-locking nuts (18), flat washers (20) and lockwashers (19).

NOTE:

Orient all parts as shown in Figure 6-4 during assembly operations.

- b. Slide the blower wheel (16) on the motor shaft and tighten the set screw lightly against the flat portion of the motor shaft.
- c. Place the blower housing (13) in position on the backplate (17) and install screws (14) and lock washers (15).
- d. Attach the radio-noise filter (9) at the point shown with the screw (10) and lockwasher (11). The motor ground lead terminal (24) may be grounded to the back plate or to the airframe.
- e. Attach the inlet flange (4) and blower inlet adapter (29), if used, to blower housing (13). If inlet adapter (29) is not used, install the inlet flange (4) with three screws (5) and lockwashers (6). If the adapter (29) is used, attach it and cover plate (25) with three screws (26) and lockwashers (27). Make sure gasket (28) is in place.
- f. Loosen the Allen set screw in the blower wheel (16) and shift the wheel on the motor shaft until it is near the inlet in the blower housing. (Add a drop of oil to shaft). Tighten the set screw securely. The blower wheel should just clear the inlet flange when rotated at full rpm. Spin the blower wheel by hand

for clearance check; then apply proper voltage to run motor and recheck for proper clearance.

- g. Slide the blower outlet adapter (1) on the blower housing (13) and install the two sheet-metal screws (3) and lockwashers (2).

4.13 Reassembly of Fuel Pump (See Figure 4-1)

- a. Insert the plunger assembly (8) in the tube with the buffer-spring end first. Check for proper fit by slowly raising and lowering the plunger in the tube; it should move freely without any tendency of sticking. A click should be heard each time the plunger approaches the top of the tube. If this click cannot be heard, the interrupter assembly in the sealed portion of the pump is not functioning properly and the pump assembly must be replaced.
- b. Install the plunger spring (7).
- c. Place the spring-cup gasket (6) in position on the plunger spring cup (5) and carefully attach this assembly to the pump body (9) with the three screws (4). Tighten screws securely.
- d. Carefully install the screen (3), place cover gasket (2) in position in cover (1) and attach the cover to the pump body (9).
- e. Hold the pump body securely with one hand and tighten the cover (1) into place on the pump body bayonets with a 5/8 inch open-end wrench or box socket.

SECTION V - TEST PROCEDURE

5.1 General Information

A test of all components should have been made after overhaul to insure proper operation. Some shops may not have complete testing facilities for measuring air flows, pressure drops and other factors which would be accomplished in a laboratory-type test. If such a test cannot be made, install the heater and check operation on the ground and in the air to determine if operation is normal. In shops where complete test equipment is available and a complete functional test can be performed, the test routine described in subsequent paragraphs should be made.

5.2 Test Procedure

5.3 Equipment Required (See Figure 5-1)

- a. An improvised stand to hold the heater during test. The heater should be located far enough away from any combustible material or atmosphere to avoid all hazards. A location should be chosen where exhaust can be dispelled. Do not add an excessive extension to the heater exhaust.
- b. A source of fuel capable of being regulated at proper operating pressure for the particular heater being tested. (Refer to the Table of Specifications.)
- c. The combustion air blower to be used with the heater should be used for the test.
- d. A 24-volt (or 12-volt) current supply, which may be a d-c generator with a rheostat, ammeter and voltmeter in the line to control and indicate the current draw and voltage output.
- e. Two water manometers (zero to 5.0-inch water column) for measuring the pressure in the ventilating air duct and in the combustion air stream.
- f. A piece of duct to be attached to the downstream end of the heater. It should have a minimum length of 24-inches and the same diameter as the heater being tested. A 2.5" diameter orifice should be centrally located at the outlet end. An aperture should be provided for the thermometer and duct switch and a static tap should be attached as shown in Figure 5-1.
- g. A thermometer with 500°F scale.
- h. A fuel-pressure gage.
- i. A controlled source of compressed air for final leakage test.

5.4 Operational Test (See Figures 5-1 and 5-2)

- a. Connect the heater to the test setup as shown in Figure 5-1. Make sure the combustion air blower is mounted securely and that the heater is clamped to its supporting stand.

- b. Insert the duct switch in the sheet-metal extension tube at the location shown in Figure 5-1.

- c. Connect components and heater as outlined in the wiring connection diagram, Figure 5-2. The power supply switch should be open.

- d. Connect the power source to the heater.

- e. Disconnect wire lead from terminal No. 3 on the heater side of heater terminal strip to prevent the heater from lighting, and close the power source switch to check operation of blowers. The combustion air blower and ventilating air blower should operate at full speed with no blower wheel interference. If either blower fails to run, locate and correct the trouble before proceeding with the test.

- f. Connect a voltmeter across the two combustion air pressure switch terminals to determine if the switch is closed, which would be indicated by a zero reading on the meter. If a full voltage reading is obtained, the combustion air supply is either inadequate or the switch is defective or improperly adjusted. Make necessary corrections.

- g. Observe the manometer connected to the ventilating air pressure tap, which should show a reading of 1.1 inches of water (minimum) at rated voltage.

- h. Observe the manometer connected to the combustion air tube tap, which should show a reading of 1.5 inches of water (minimum) at rated voltage.

- i. Open the power supply switch and reconnect the terminal lead disconnected in preceding Step e.

- j. Close the power supply switch and turn on the fuel supply. The heater should light within five seconds (may require slightly longer for air to be purged from fuel lines on the first trial).

- k. Observe operation of duct switch which should control heater operation according to the switch setting.

- l. Connect a jumper across the terminals of the duct switch to make it inoperative and observe action of the cycling switch. The cycling switch should cycle to control the outlet air temperature at approximately 250°F (nominal). This is a function of ambient temperature and air flow conditions. If operation is within a range of 190°F to 290°F, the switch is operating normally. If the switch is out of range it can be reset. Turn adjusting screw clockwise to decrease temperature and counterclockwise to increase temperature. If adjustment fails to restore proper temperature range, replace the switch. After resetting, seal adjustment screw with Glyptol (G.E. No. 1202 or equivalent) on shaft and switch body.

- m. With duct switch still jumped, place a jumper across the cycling switch terminals to check operation of the overheat switch. Block the ventilating air inlet

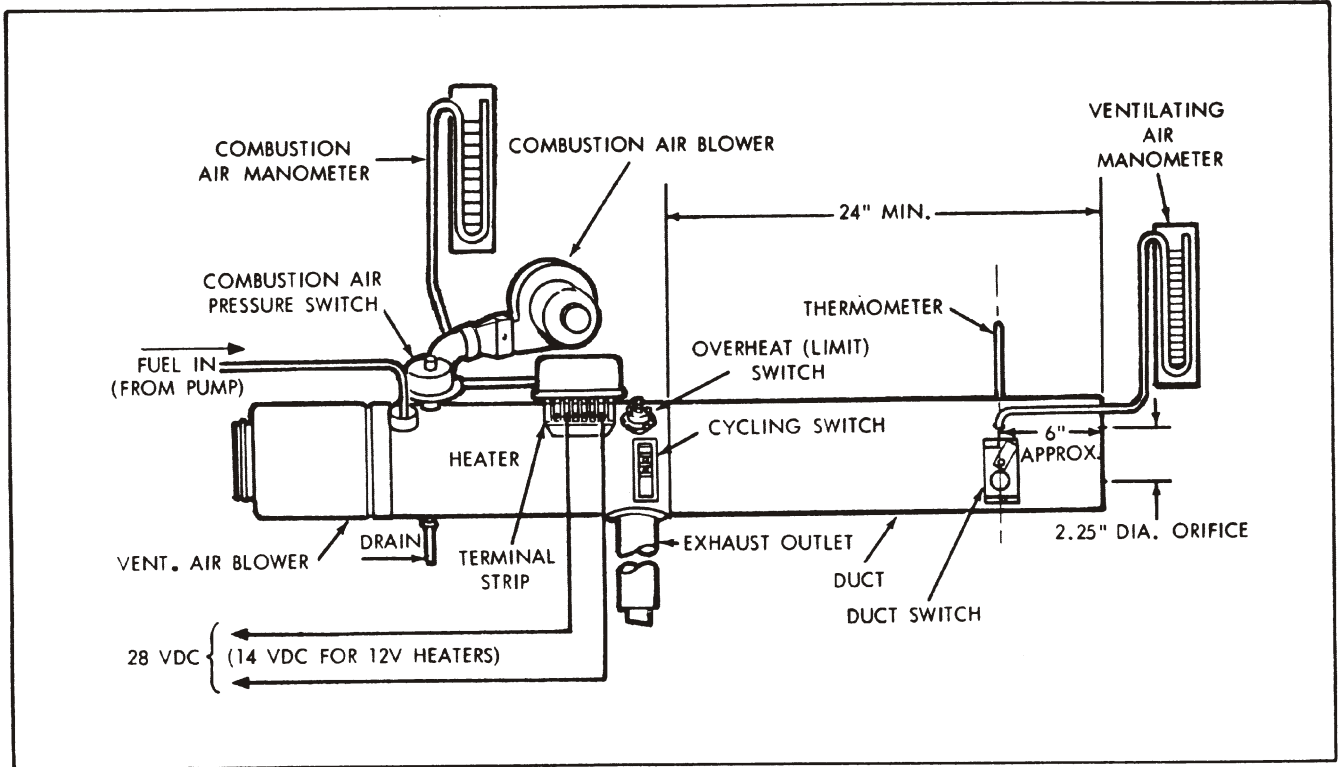

FIGURE 5-1 Suggested Set-Up for Heater Operation Test

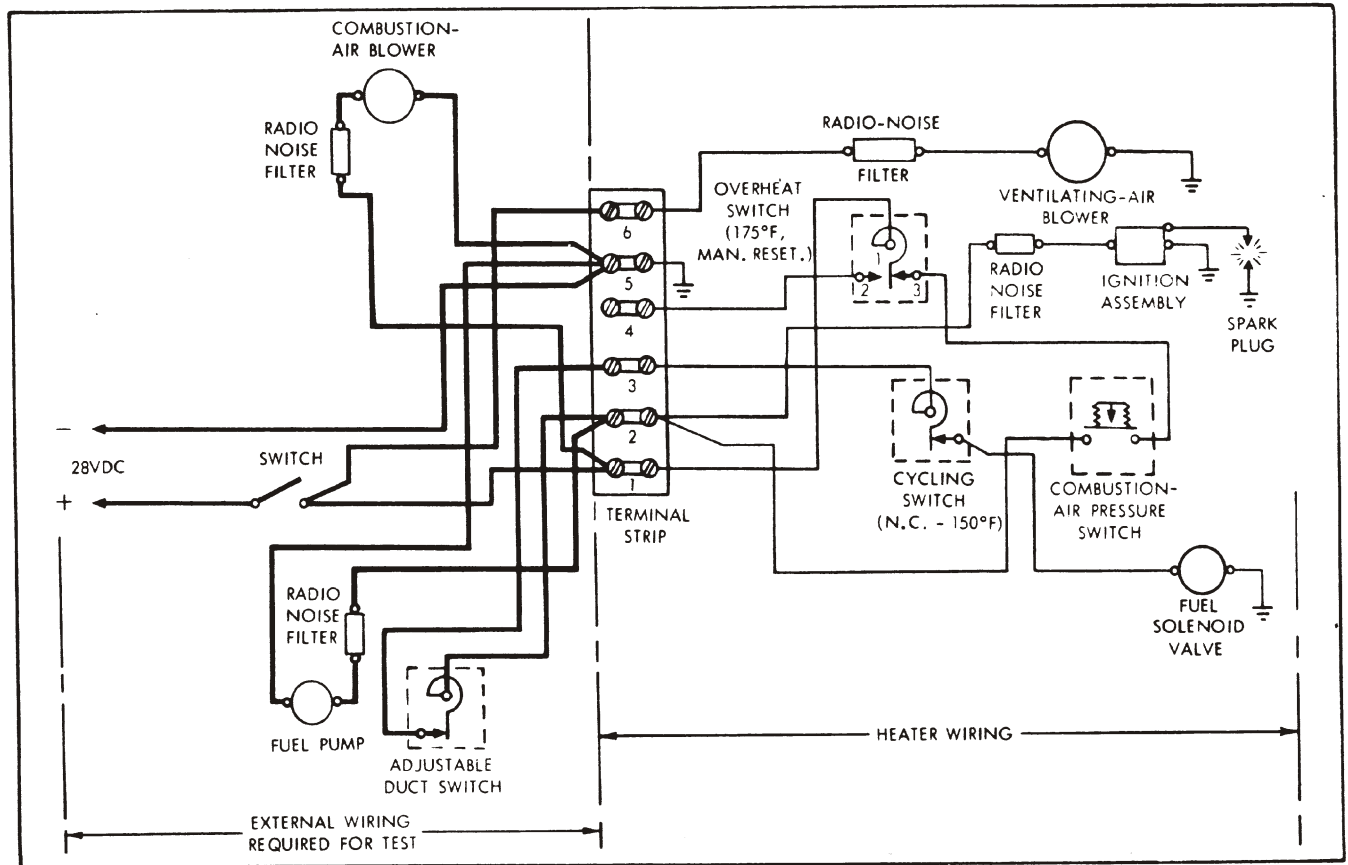

FIGURE 5-2 Wiring Connections for Heater Operation Test (Typical)

and notice if the overheat switch shuts off the heater. It should open at between 300°F and 400°F. (This is also a function of ambient temperature and air flow.) After the switch shuts off, remove ventilating air restriction; remove jumpers from cycling and duct switches and press firmly on the overheat-switch, manual reset button until it "clicks." The heater should light and operate.

n. Shut down the heater and check all components visually to make sure no damage has occurred to any of them.

o. Remove heater and other components from the test set-up and install it in the aircraft.

SECTION VI - ILLUSTRATED PARTS BREAKDOWN

This Illustrated Parts Breakdown includes exploded views of a TYPICAL aircraft heater and its components or accessories and will not in all cases show the exact detail or arrangement of all models listed.

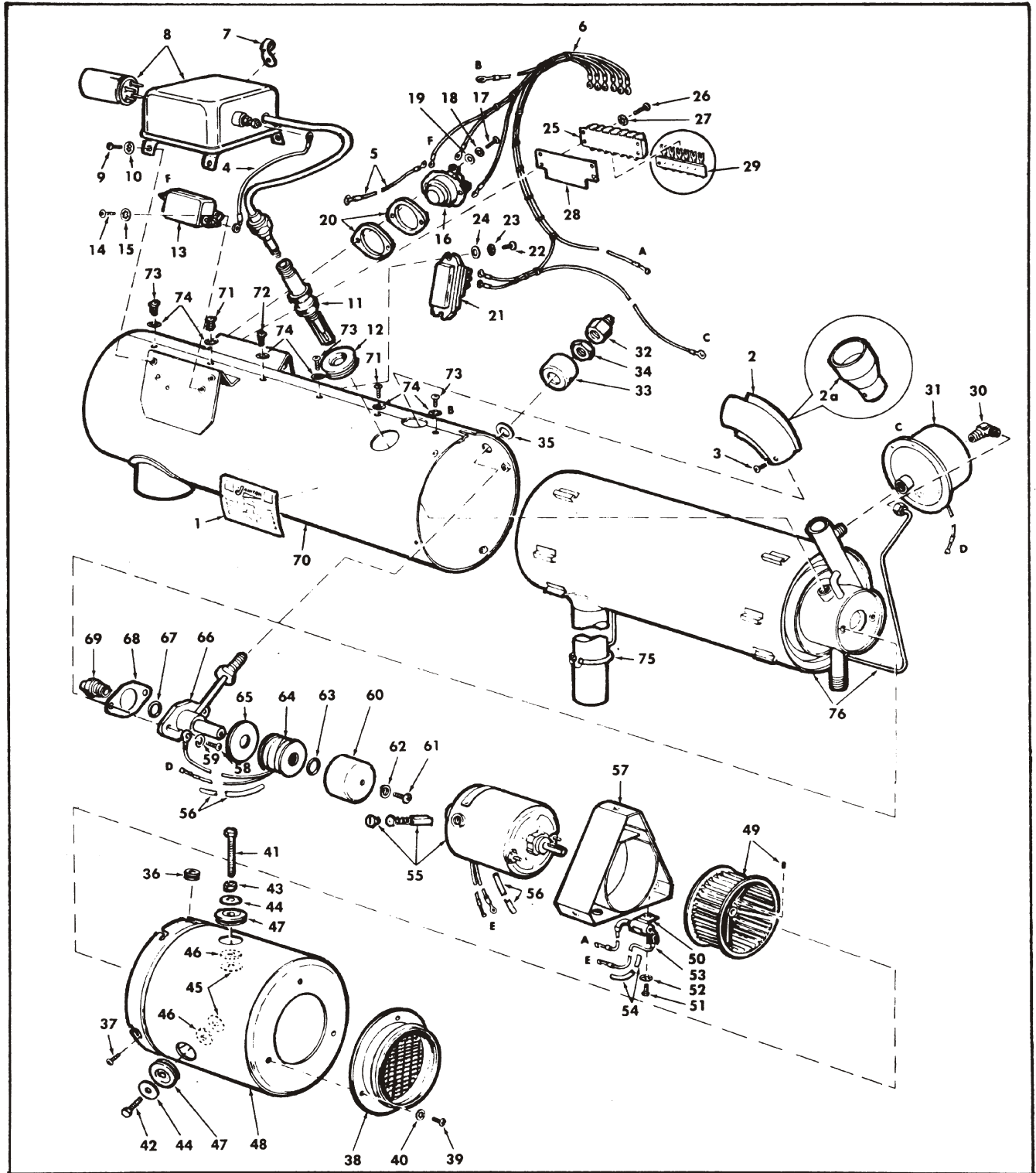

FIGURE 6-1 Exploded View of Business Aircraft Heater Assembly Non-Pressurized

| Figure And Index No. | DESCRIPTION | Figure And Index No. | DESCRIPTION | Figure And Index No. | DESCRIPTION |
|----------------------|---|----------------------|---|----------------------|--|
| 6-1 | HEATER ASSY, Business Aircraft, 12 volt system 24 volt system | -16 | . SWITCH, LIMIT (ATTACHING PARTS) | -49 | . . WHEEL ASSY (w/set screw) |
| -1 | . PLATE, IDENTIFICATION, 12 volt heater 24 volt heater | -17 | . SCREW, MACHINE | -50 | . . CAPACITOR ASSY (ATTACHING PARTS) |
| -2 | . ADAPTER, ELBOW | -18 | . WASHER, LOCK | -51 | . . SCREW, MACHINE |
| -2a | . ADAPTER (Optional Part) (ATTACHING PARTS) | -19 | . WASHER, FLAT -----*----- | -52 | . . WASHER, LOCK -----*----- |
| -3 | . SCREW, Sheet metal, rd hd -----*----- | -20 | . GASKET | -53 | . . WIRE ASSY, Blower grd |
| -4 | . WIRE ASSY, Ign. to filter | -21 | . SWITCH, CYCLING (ATTACHING PARTS) | -54 | . . SLEEVE, Hi temp insul |
| -5 | . WIRE ASSY, Blower grd | -22 | . SCREW, MACHINE | -55 | . . MOTOR ASSY, Elec, 12 volt heater 24 volt heater |
| -6 | . HARNESS ASSY, Wiring (Not available as assy) | -23 | . WASHER, LOCK | | . . . CAP, BRUSH |
| | . WIRE ASSY, Heater grd | -24 | . WASHER, FLAT -----*----- | | . . . BRUSH & SPRING ASSY |
| | . WIRE ASSY, Ter. 1 to o/h switch | -25 | . STRIP, TERMINAL (ATTACHING PARTS) | | . . . TERMINAL, Pre-insulated |
| | . WIRE ASSY, Ter. 2 to ignition filter | -26 | . SCREW, MACHINE | -56 | . SLEEVE, Hi temp insul |
| | . WIRE ASSY, Ter. 6 to blower filter | -27 | . WASHER, LOCK -----*----- | -57 | . . BRACKET ASSY, Motor mtg |
| | . WIRE ASSY, Ter. 2 to pressure switch | -28 | . INSULATOR | | . FUEL FEED, NOZZLE HOLDER & VALVE ASSY, 12 volt heater 24 volt heater (ATTACHING PARTS) |
| | . WIRE ASSY, Ter. 3 to cycle switch | -29 | . FANNING STRIP (Optional accessory) | -58 | . SCREW, MACHINE |
| | . WIRE ASSY, Pressure switch to o/h switch | -30 | . ELBOW, TUBE TO PIPE | -59 | . WASHER, LOCK -----*----- |
| | . WIRE ASSY, Cycle switch to fuel valve | -31 | . SWITCH, PRESSURE, Combustion air | -60 | . . COVER, SHELL (ATTACHING PARTS) |
| | . WIRE ASSY, Ter. 4 to o/h switch | -32 | . BUSHING, RED. ADAPT (Used on 99C42 only) | -61 | . . SCREW, MACHINE |
| -7 | . TIE, CABLE | -33 | . SHROUD, Fuel fitting (ATTACHING PARTS) | -62 | . . WASHER, LOCK -----*----- |
| | . STRAP, CABLE -----*----- | -34 | . NUT, UNIV FTG -----*----- | -63 | . . O-RING |
| -8 | . IGNITION ASSEMBLY, 12 volt heater 24 volt heater (ATTACHING PARTS) | -35 | . GASKET | -64 | . . COIL ASSY, Solenoid 12 volt heater 24 volt heater |
| -9 | . SCREW, MACHINE | -36 | . GROMMET | -65 | . . PLATE, BASE |
| -10 | . WASHER, LOCK | | . BLOWER ASSY, Vent air, 12 volt heater 24 volt heater (ATTACHING PARTS) | -66 | . . VALVE ASSY |
| | . VIBRATOR, Ignition -----*----- | -37 | . SCREW, SEMS -----*----- | -67 | . . O-RING |
| -11 | . PLUG, SPARK | -38 | . . ADAPTER & SCREEN (ATTACHING PARTS) | -68 | . GASKET |
| -12 | . GROMMET | -39 | . . SCREW, MACHINE | -69 | . NOZZLE, SPRAY |
| -13 | . FILTER, Radio noise (ATTACHING PARTS) | -40 | . . WASHER, LOCK -----*----- | -70 | . JACKET ASSY (ATTACHING PARTS) |
| -14 | . SCREW, MACHINE | -41 | . . SCREW, MACHINE, HEX | -71 | . SCREW, MACHINE |
| -15 | . WASHER, LOCK -----*----- | -42 | . . SCREW, MACHINE, HEX | -72 | . SCREW, MACHINE |
| | | -43 | . . NUT, PLAIN, HEX | -73 | . SCREW, MACHINE |
| | | -44 | . . WASHER, FLAT | -74 | . WASHER, LOCK -----*----- |
| | | -45 | . . WASHER, FLAT | -75 | . GASKET, ROPE |
| | | -46 | . . WASHER | -76 | . TUBE, COMBUSTION LINER, CASING TUBE, Comb. air switch |
| | | -47 | . . GROMMET | | |
| | | -48 | . . HOUSING, Blower | | |

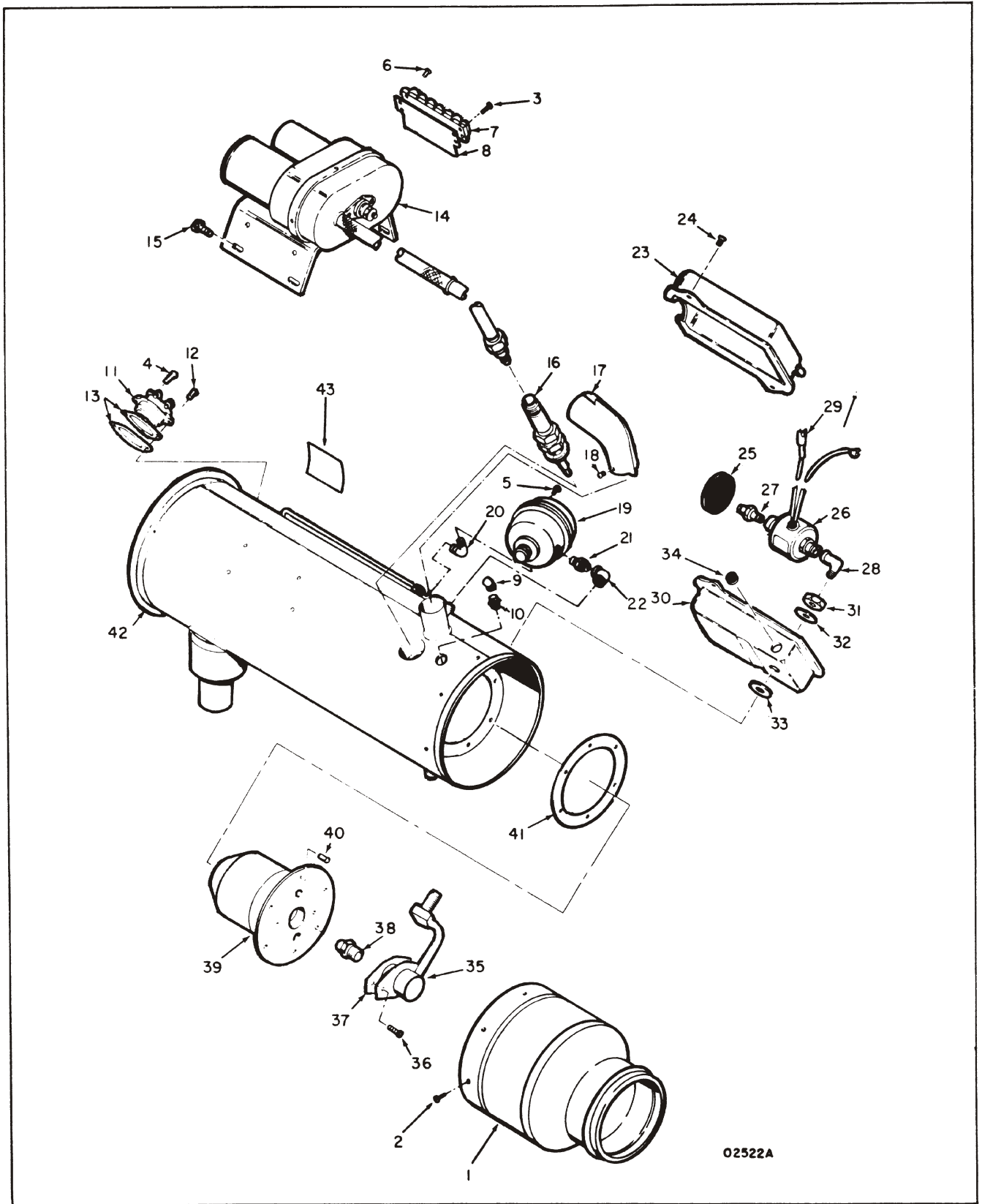

FIGURE 6-2 Typical Pressurized Heater

LEGEND FOR FIGURE 6.2

- | | | |
|-----------------------|---------------------------|---|
| 1. Vent air blower | 16. Spark plug | 31. Nut |
| 2. Screw | 17. Adapter elbow | 32. Washer |
| 3. Screw | 18. Screw | 33. Gasket |
| 4. Screw | 19. Combustion air switch | 34. Grommet |
| 5. Screw | 20. Elbow | 35. Fuel feed assembly |
| 6. Screw | 21. Nipple | 36. Screw |
| 7. Terminal strip | 22. Elbow | 37. Gasket |
| 8. Insulator | 23. Upper fuel shroud box | 38. Spray nozzle |
| 9. Grommet | 24. Screw | 39. Combustion head assembly |
| 10. Socket housing | 25. Grommet | 40. Screw |
| 11. Limit switch | 26. Solenoid assembly | 41. Gasket |
| 12. Screw | 27. Nipple | 42. Combustion tube and jacket assembly |
| 13. Gasket | 28. Elbow | 43. Identification plate |
| 14. Ignition assembly | 29. Pin housing | |
| 15. Screw | 30. Lower fuel shroud box | |

LEGEND FOR FIGURE 6.3

- | | | |
|----------------|---------------------------------|---------------------------|
| 1. O-ring | 11. Motor | 21. Brush |
| 2. Screw | 12. Head assembly | 22. Brush assembly |
| 3. Fastener | 13. Nut | 23. Brush spring |
| 4. Fan | 14. Lock washer | 24. Brush holder |
| 5. Mounting | 15. Bolt | 25. Armature assembly |
| 6. Nut | 16. Cable assembly | 26. Ball bearing |
| 7. Screw | 17. Capacitor | 27. Spring tension washer |
| 8. Strip | 18. Screw | 28. Stator |
| 9. Pin housing | 19. Lock washer | 29. Rear housing head |
| 10. Pin | 20. Brush holder plate assembly | 30. Housing assembly |

NOTE:

Refer to specific heater for part numbers.

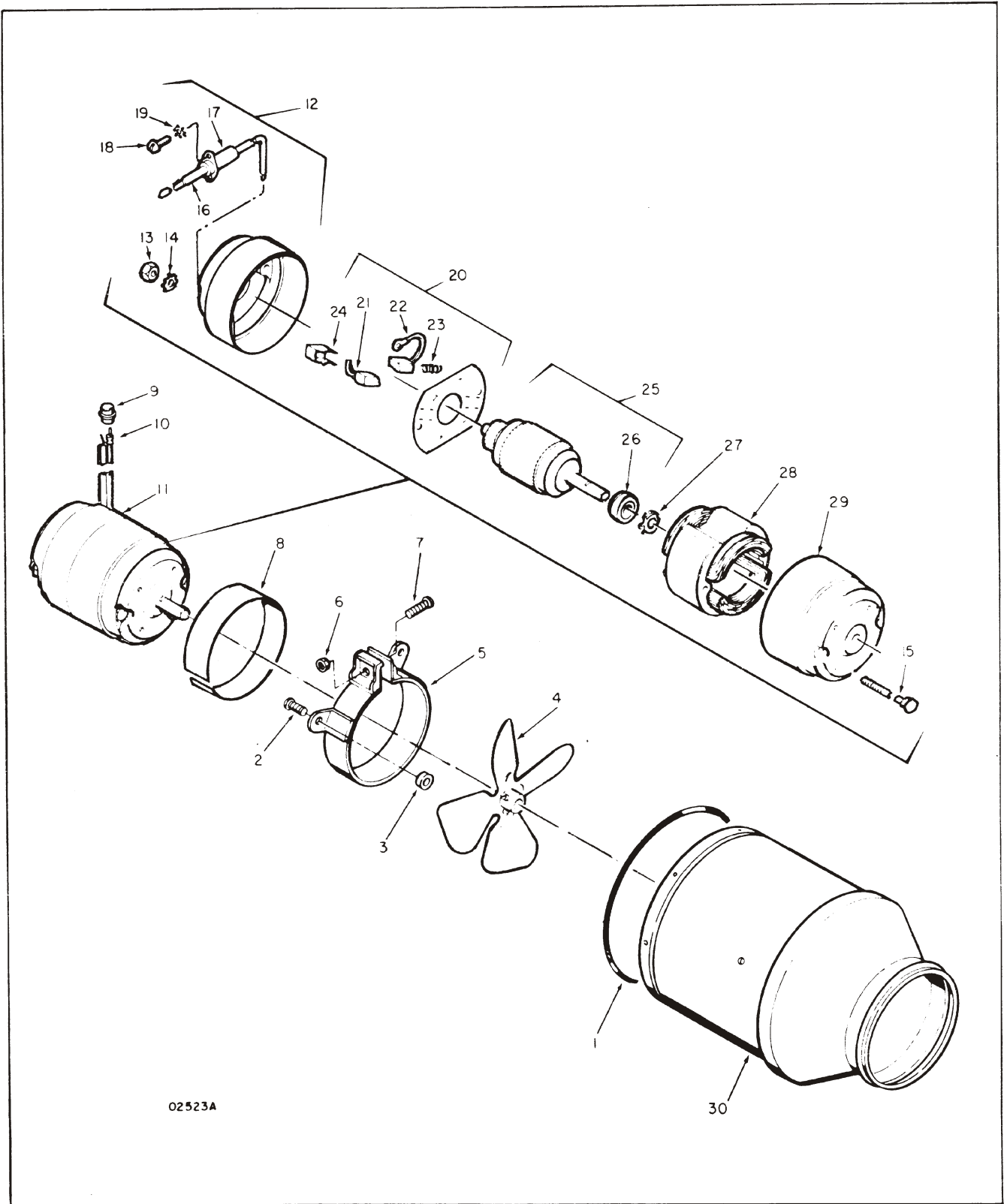

02523A

FIGURE 6-3 Vent Air Blower Assembly

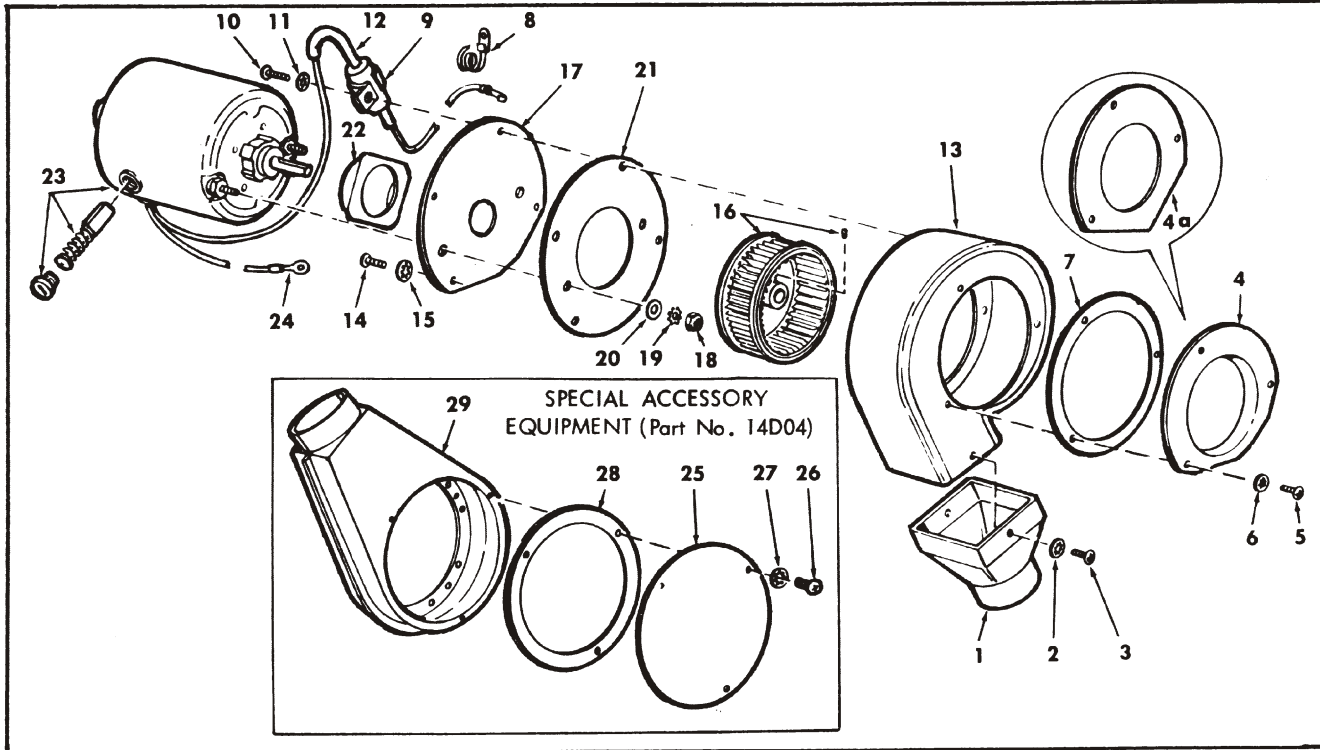

FIGURE 6-4 Exploded View of Combustion Air Blower and Motor Assembly

- NOTE -

Parts used on both 12 and 24 volt systems are shown in a single line listing in the model number column. Where parts vary as a result of voltage, they appear on separate lines for their particular index reference number.

| Figure & Index No. | DESCRIPTION | Figure & Index No. | DESCRIPTION |
|--------------------|---|--------------------|--|
| 6-4- | COMBUSTION AIR BLOWER AND MOTOR ASSY, 12 volt system 24 volt system | -16 | WHEEL ASSY, BLOWER (w/setscrew) |
| -1 | ADAPTER, Outlet (ATTACHING PARTS) | -17 | PLATE, BACK (ATTACHING PARTS) |
| -2 | SCREW, TAPPING, Rd Hd | -18 | NUT, PLAIN, HEX |
| -3 | WASHER, LOCK | -19 | WASHER, LOCK |
| * | | -20 | WASHER, FLAT |
| -4 | FLANGE, Inlet | -21 | GASKET, Back plate |
| -4a | PLATE, Inlet (ATTACHING PARTS for index Nos. 4 & 4a) | -22 | SPACER |
| -5 | SCREW, TAPPING, Rd Hd | -23 | MOTOR ASSY, Electric, 12 volt heater 24 volt heater |
| -6 | WASHER, LOCK | | CAP, BRUSH |
| * | | | BRUSH AND SPRING ASSY |
| -7 | GASKET, Inlet | -24 | TERMINAL, Pre-insulated |
| -8 | TIE, Cable | | SPECIAL ACCESSORY EQUIPMENT |
| -9 | CAPACITOR (ATTACHING PARTS) | | ADAPTER ASSY, BLOWER INLET (Individual parts of above assembly) |
| -10 | SCREW, TAPPING, Rd Hd | -25 | 14D08 COVER 1 |
| -11 | WASHER, LOCK | | (ATTACHING PARTS) |
| * | | -26 | F45A27 SCREW, Sheet Metal 3 |
| -12 | SLEEVE, Hi Temp insulating | -27 | AN936A10 WASHER, Lock 3 |
| -13 | HOUSING, BLOWER (ATTACHING PARTS) | | * |
| -14 | SCREW, TAPPING, Rd Hd | -28 | 17D85 GASKET 3 |
| -15 | WASHER, LOCK | -29 | 25D79 ADAPTER 1 |
| * | | | |

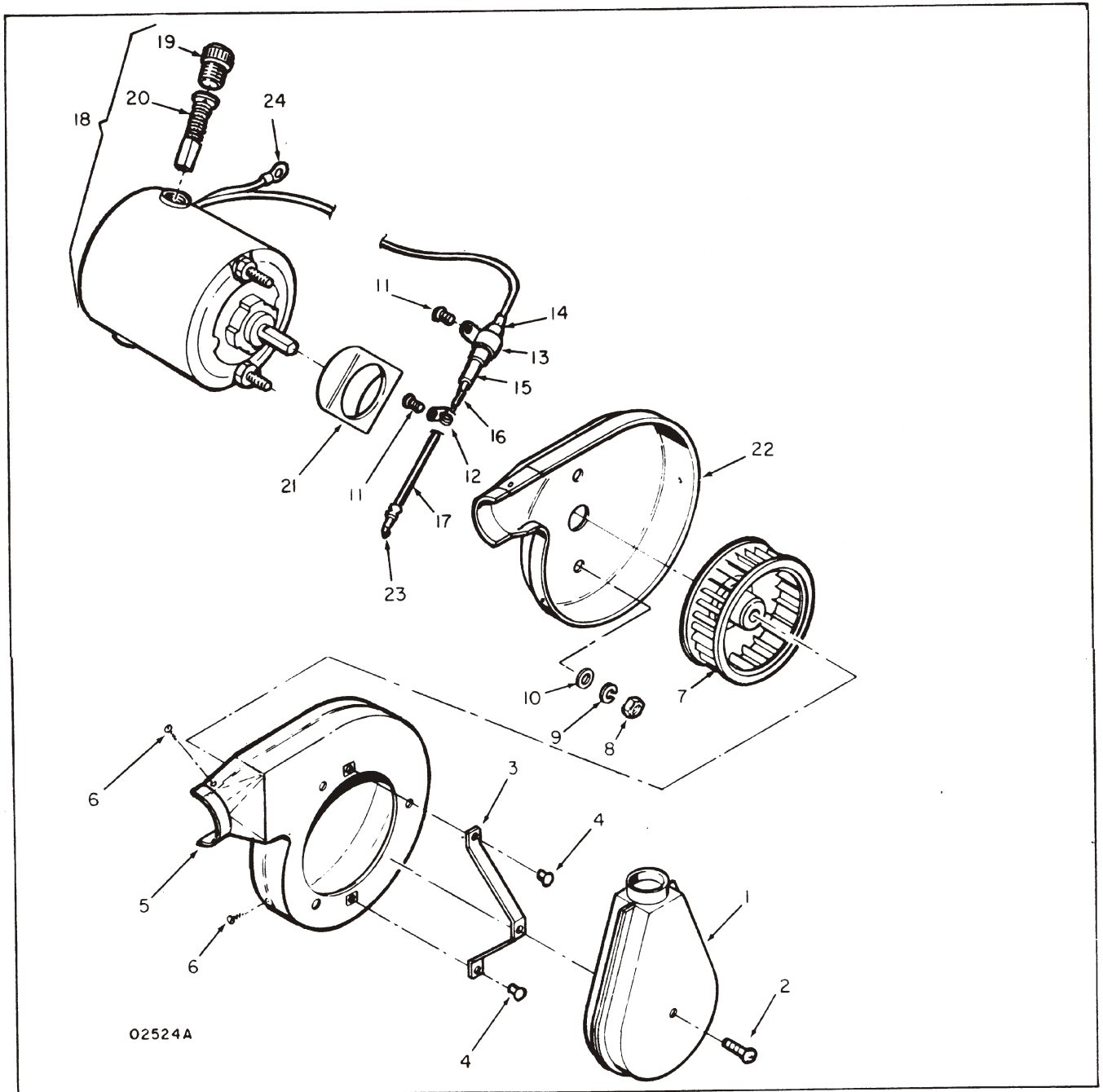

FIGURE 6-5 Combustion Air Blower Assembly

LEGEND FOR FIGURE 6.5

- | | | |
|------------|----------------|-------------------------------|
| 1. Adapter | 9. Lock washer | 18. Motor |
| 2. Screw | 10. Washer | 19. Brush cap. |
| 3. Bracket | 11. Screw | 20. Brush and spring assembly |
| 4. Rivet | 12. Cable tie | 21. Spacer |
| 5. Housing | 13. Capacitor | 22. Housing |
| 6. Screw | 14. Sleeve | 23. Terminal |
| 7. Wheel | 15. Sleeve | 24. Terminal |
| 8. Nut | 16. Splice | |
| | 17. Wire | |

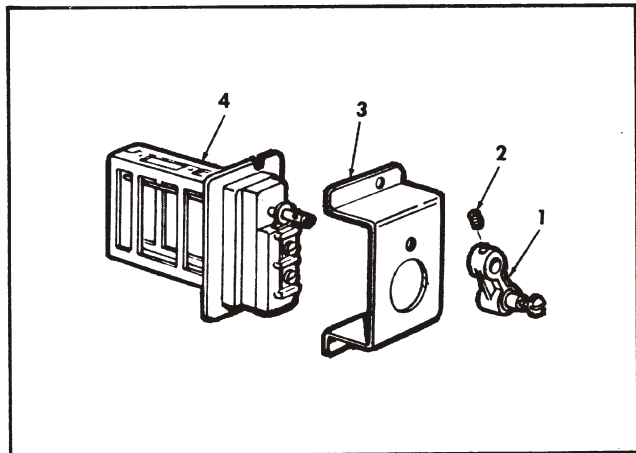

Figure 6-6. Exploded View of Adjustable Duct Switch Assembly

| Fig. & Index No. | DESCRIPTION |
|------------------|--|
| 6-6- | SWITCH ASSY, Adj. duct |
| -1 | . LEVER ASSY, Switch (ATTACHING PARTS) |
| -2 | . SCREW, Set ----- * ----- |
| -3 | . COVER SWITCH |
| -4 | . SWITCH, Adj. duct |

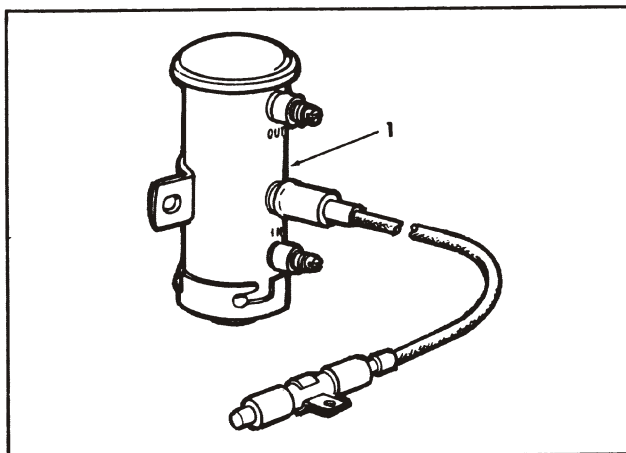

Figure 6-7. Electric Fuel Pump

| Fig. & Index No. | DESCRIPTION |
|------------------|--|
| 6-7- | PUMP, Fuel, Elec, radio suppressed 12 volt heater 24 volt heater |

**BUSINESS
and UTILITY
AIRCRAFT
HEATERS**

**JANITROL AERO DIVISION
MIDLAND ROSS**