

26 AD Pyp

IF YOU CAN'T FLY UPSIDEDOWN  
*then*  
YOU CAN'T FLY!!!!!!

## AVIAT AIRCRAFT INC.

PITTS SPECIAL S-2B AIRCRAFT

OWNER'S AND MAINTENANCE MANUAL

70197-001

1-1-97

Light Aircraft Manufacturers

672 South Washington  
P.O. Box 1240  
Afton, WY 83110  
telephone: 307-886-3151  
facsimile: 307-886-9674  
e-mail: [aviat@aviataircraft.com](mailto:aviat@aviataircraft.com)

**PITTS S-2B  
OWNER'S MANUAL**

**PREFACE**

**CONGRATULATIONS!**

As the owner of a Pitts Model S-2B airplane, you can be proud in the knowledge that the machine you now possess will offer fewer limitations to your progress in the world of flight than any other airplane in the world.

This owner's manual has been prepared to help you realize the full potential of this remarkable airplane.

**AVIAT AIRCRAFT INC.**

**PITTS S-2B  
OWNER'S MANUAL**

**TABLE OF CONTENTS**

<u>General Specification</u>	Page 3
<u>About Your S-2B</u>	Page 5
<u>Flying Your S-2B</u>	Page 6
<u>Getting The Most From Your S-2B</u>	Page 9
<u>Performance Charts:</u>	
V-G Diagram	Page 12
Manifold Pressure vs. RPM	Page 13
Altitude Conversion	Page 14
Fuel Flow vs. Nozzle Pressure	Page 15
Fuel Consumption vs. Horsepower	Page 16
Cruise Performance	Page 17
Maximum Crosswind Velocities	Page 18
<u>Erection of the Airplane</u>	Page 19
<u>Service and General Maintenance</u>	Page 22
<u>Maintenance Schedule</u>	Page 25
50 hour inspection	Page 28
100 hour inspection	Page 32
1000 hour inspection	Page 32
<u>Electrical Schematic</u>	Page 34

**PITTS S-2B  
OWNER'S MANUAL**

**GENERAL SPECIFICATION**

<u>CRUISING SPEED:</u>	<u>SEA LEVEL</u>	<u>5000 FT.</u>
75% power (2600 RPM)	175 MHP TAS	180 MPH TAS
65% power (2400 RPM)	165 MPH TAS	170 MPH TAS
50% power (2200 RPM)	145 MPH TAS	153 MPH TAS
<u>HIGH SPEED</u> , sea level (2700 RPM, full-throttle)		195 MPH TAS
<u>RATE OF CLIMB</u> , sea level, (rated power, 260 HP)		2145 FPM
<u>SERVICE CEILING</u> , (rated power)		22000 FT.
<u>STALLING SPEED</u>		63 MPH IAS
<u>CRUISING RANGE</u> , sea level, @ 165 mph, 65% power (statute), on 28 gals.		350 MILES
<u>TAKE-OFF RUN</u> , sea level, no wind, standard day		560 FT.
<u>LANDING RUN</u> , sea level, no wind, standard day		1060 FT.
(The above performance figures are dependent on proper engine power output, are for airplanes which have had no additional drag-producing items attached to their exterior surfaces, and which are in the condition as received from the factory without any modifications by others).		
<u>BAGGAGE COMPARTMENT</u>		maximum 20 LB.
<u>WEIGHTS</u>		
acrobatic category, maximum		1625 LB.
normal category, maximum		1700 LB.
equipped empty weight		1200 LB.
(Equipped empty weight includes flight instruments, unusable fuel, oil and typical avionics).		
<u>USEFUL LOAD</u>		
acrobatic		425 LB.
normal		500 LB.
<u>WING AREA AND LOADINGS</u>		
Wing area		125 SQ. FT.
Wing loading		
acrobatic max. gross (1625 lb.)		13 LB. / SQ. FT.
normal max. gross (1700 lb.)		13.6 LB. / SQ. FT.
Power loading, at acrobatic max. gross		6.25 LB. / HP
<u>DIMENSIONS</u>		
Wingspan		20 FT.
Length		18 FT.
Height (three-point)		6 FT. 8 IN.
<u>PROPELLER AND EQUIPMENT</u>		
Propeller: Hartzell HC-C2YR-4CF / FC8477-4, constant speed, two-blade with Hartzell governor and spinner.		

**PITTS S-2B  
OWNER'S MANUAL**

GENERAL SPECIFICATION (cont'd)

MT Propeller MTV-9-B-C / C190-18a constant speed composite three-blade with Hartzell governor and MT spinner.

Hartzell Propeller HC-C3YR-1A / 7690C constant speed composite three-blade with Hartzell governor, spinner and accumulator.

ENGINE

Lycoming AEIO-540-D4A5, fuel injected,  
260 rated hp at 2700 RPM

ENGINE EQUIPMENT

Starter  
Alternator  
Voltage regulator  
Overvoltage relay  
Battery  
Fuel pumps (engine-driven and electric boost)  
Alternate induction air system  
Inverted oil system  
Fuel injection  
Exhaust manifolds (stainless steel)

FUEL AND OIL CAPACITY

Fuel capacity 29 gallons, 28 useable  
Oil capacity 12 quarts (minimum safe quantity 6 quarts)

LANDING GEAR

Main gear:	welded steel tubular, sprung by no. 1280 H.D. shock cords, two per gear
Main wheels:	Cleveland 5.00 x 5 size
Main tires:	5.00 x 5, type III, 6-ply rating, (tube type)
Tailwheel unit:	Maule SFS-1-4

# **PITTS S-2B OWNER'S MANUAL**

## **ABOUT YOUR S-2B**

The story of your S-2B began in 1945, when Curtis Pitts first flew his prototype single-place acrobatic biplane which was to become the fore-runner of the now world-renown "Pitts Special" series of championship acrobatic airplanes.

Since that day over fifty years ago, constant evolutionary changes and improvements have produced the little airplane which was to become instrumental in bringing to the USA, in 1970 for the first time and again in 1972, the coveted World Team Aerobatic Championship.

From this half-century of continuous and recognized successful development has evolved the Model S-2B which you now own.

Your S-2B airplane is in every major performance respect the equal of its breath-taking "little brother", with the added features, of course, of being somewhat larger and, therefore, more visible in the air and having the fuel capacity and cruising speed to make it a more pleasant cross country airplane.

On the following pages of this handbook, the important characteristics of your S-2B are described, along with suggestions and recommendations to help you fully realize the potential of the airplane.

Many procedures which are fully described in the FAA-Approved Flight Manual are not repeated here, as for example starting procedures, checklists, takeoff and landing performance and emergency procedures. This Owners Manual is only for the purpose of explaining in some detail how best to use your airplane, where these details are not provided in the Flight Manual. Therefore, be extremely familiar with your Airplane Flight Manual.

# PITTS S-2B OWNER'S MANUAL

## FLYING YOUR S-2B

### SAFETY FEATURES AND SUGGESTIONS

Your safety in this, (or any airplane) is, of course, dependent on the characteristics of the airplane as well as your own knowledge of them. The Model S-2B combines features of outstanding maneuverability and stability with exceptional and proven structural strength, to a degree that make it inherently safe, provided you become familiar with the airplane itself. Therefore, the following suggestions are provided:

### VISIBILITY

The visibility from this airplane is, of course, extremely good; however, so is its performance in acrobatic maneuvers. Therefore, be extremely careful at all times to ensure that no other aircraft have entered the area where you are flying acrobatically.

### STALL WARNING INDICATOR

A stall warning indicator, (angle of attack sensor) connected to an aural horn is provided, in order to comply with Federal Aviation Regulations.

### STRUCTURE

The airframe of the Model S-2B has been tested to loads in excess of the Federal Aviation Agency Requirements for the stringent Acrobatic Category, at 1625 lb. gross weight. This means in practical language, that at indicated airspeeds of 154 mph or less, you may apply sudden full aileron, rudder, or nose-up elevator deflection without exceeding the airframe minimum design loads. Sudden full nose-down elevator may likewise be applied at 106 mph indicated or less, without exceeding the design loads. These relationships are shown graphically on the V-G diagram of page 12. It is important to understand that airspeed limitations for application of various combinations of controls are lower than these figures as shown in the approved list of maneuvers. Note the maximum entry speeds for snap rolls during which maximum deflection of all three controls may be applied.

If you now compare the recommended entry speeds for various demonstrated maneuvers shown on this page, with the V-G diagram, it should be clear that if you feel you need more airspeed than the tabulated values show, you are not properly performing the maneuver, and you may be overloading the airframe. Do not exceed the limitations shown on the V-G diagram; every maneuver in the FAI catalog can be performed from the combinations of the ones shown here.

### APPROVED MANEUVERS AND RECOMMENDED ENTRY SPEEDS, MPH IAS

<u>MANEUVER</u>	<u>INSIDE</u>		<u>OUTSIDE</u>	
	<u>max.</u>	<u>min.</u>	<u>max.</u>	<u>min.</u>
Loop (Up)	180	130	180	130
Loop (Down)	100	70	100	70
Slow Roll	180	100	180	100
Barrel Roll	180	130	180	130
Snap Roll	140	90	110	90
Hammerhead	180	130	180	130
Lazy Eight	180	140	180	140
Chandelle	180	140	180	140
Stalls And Spins	(slow deceleration)			

# PITTS S-2B OWNER'S MANUAL

## FLYING YOUR S-2B (cont'd)

### SEAT BELTS AND SHOULDER HARNESS

Your S-2B is equipped with seat belts and shoulder harness. Always use them both when you fly, acrobatic or not.

Note the Federal Aviation Regulations with respect to the use of parachutes during acrobatic flight.

When parking the airplane outdoors, the seat belt secured around the control stick provides a simple effective control lock.

### ACROBATIC FLIGHT

The following points are so obvious as to be self-evident, but their importance is so great that we repeat them here.

Do not perform acrobatics with baggage.

Do not perform acrobatics with less than  $\frac{1}{4}$  tank of fuel, at low altitudes.

Do be certain that you have ample altitude for the maneuvers you want to perform.

Do be sure that you are familiar enough with the maneuvers, and the weight and center of gravity limits shown in Section 6 of the Approved Flight Manual.

### INVERTED SPINS

The S-2B has been demonstrated to meet the stringent requirements of the Federal Aviation Agency for spin recovery at all weight and center of gravity locations inside the approved envelope, (both right side up and inverted), and from spins with controls both pro- and anti-spin prior to recovery. However, this will not be of any benefit to you unless you are sufficiently proficient to be able to tell whether you are spinning right side up or inverted. The only way for avoiding difficulty in this area of the acrobatic flight spectrum is for you to obtain sufficient dual instruction from a competent instructor that you are able to distinguish the inverted spin from the normal spin, and then to maintain this capability by practice. We cannot over-emphasize the importance of doing this.

### GROUND-HANDLING

The S-2B ground-handling qualities are typical of the tail-wheel type, and entirely normal in this respect, both on the take-off ground-run and the landing roll-out. Because of their popularity in recent years, you may be considerably more familiar with tricycle-gear handling qualities than tail-wheel types. If so, again you will be well advised to obtain some dual instruction in tail-wheel types. Also, keep the following points in mind:

Do not over-control the airplane on the ground with brakes and rudder. Adjust your responses to the airplane's and you will find your S-2B as pleasant on the ground as it is in flight.

Toe-brakes are standard equipment.



**PITTS S-2B**  
**OWNER'S MANUAL**  
FLYING YOUR S-2B (cont'd)

GROUND-HANDLING

On cross-wind landing, (see cross-wind chart, page 18) develop the habit of removing the crab before touchdown, lest someday on pavement, the airplane will inevitably ground-loop. When pushing your S-2B, in the hangar and on the ramp, use the interplane I-struts for push points. Do not push the spinner, the propeller, or the empennage. CAUTION: Be extremely careful when moving the propeller when the engine is warm, as residual fuel in the intake ports may fire and cause the engine to kick. If it is necessary to move the propeller, turn it opposite its normal rotation, and make sure the magneto switch is off.

When leaving the airplane parked outside a hangar, you should:

Leave it parked into the wind

Chock both main wheels

Secure the stick with the seat-belt

**PITTS S-2B  
OWNER'S MANUAL**

**GETTING THE MOST FROM YOUR S-2B**

**WEIGHT AND BALANCE**

Section 6 of the S-2B Airplane Flight Manual provides loading examples and instructions for loading your S-2B so that your airplane will always be within the approved weight and center of gravity envelope. This is of importance not only from the standpoints of safety and legality, but also because it is within these limits that the optimum design performance of the airplane is obtained, so become familiar with these procedures.

The approved weight and center of gravity limit points are noted below for reference:

	<u>ACROBATIC CATEGORY</u>			
	<u>WEIGHT</u>	<u>ARM. FS</u>	<u>MOMENT</u>	<u>%MAC</u>
Most forward	1475	86.35	127366	16.3
Most fwd. at max. gross	1625	89.58	145568	24.6
Most rearward at max. gross or less	1625	90.50	147063	27.0
	<u>NORMAL CATEGORY</u>			
Most forward	1475	86.35	127366	16.3
Most fwd. At max. gross	1700	88.50	150450	21.8
Most rearward at max. gross or less	1700	90.2	153340	26.3

Section 6, Weight and Balance, of the FAA-approved Airplane Flight Manual for your S-2B contains the following information: A statement of the actual weight, arm, and moment of your empty airplane with a diagram showing the weighing and leveling points; a graph of the center of gravity limits for different weights; and an equipment list giving the weights and arms of all equipment items installed at the factory and included in the empty weight. The FAA-approved Flight Manual must be carried in the airplane. Study it thoroughly. The first part of the Weight and Balance section contains a diagram of the airplane with the reference stations and leveling provisions necessary to weigh the airplane properly, and you will note that this section also lists the serial number of your airplane and the signatures of the personnel responsible for weighing your airplane.

Familiarity with this section of the Flight Manual will enable you to perform efficiently the simple calculations which are part of your responsibility as pilot in command to ensure that the airplane is properly loaded at all times.

**PERFORMANCE CHARTS**

Flight planning depends on careful analysis of each flight in advance, in order to best utilize the capabilities of your S-2B.

Most of the performance data in this section has been reduced to true airspeed and standard conditions in accordance with NASA formulas so as to present the information in terms of performance which can be readily converted to actual conditions. However, to be able to get the best use from the graphs, you should understand the relationships between the conditions shown in the graphs and your instrument readings.

No allowances have been made in the graphs for fuel reserves or for variables such as winds, and fuel consumed in warm-up and taxiing. You must make corrections for these factors as they actually occur. You would be very imprudent, for example, to plan any flight with no allowances for fuel reserves or for unforeseen headwinds.

The flight tests from which the performance data was derived were flown with a clean airplane properly rigged and loaded, and with an engine capable of delivering full rated power.

## PITTS S-2B OWNER'S MANUAL

### GETTING THE MOST FROM YOUR S-2B (cont'd)

Two variable factors affect the readings of our altimeter and airspeed indicator. They are the actual barometric pressure and the outside air temperature. You must allow for these two factors in changing actual instrument reading under your actual conditions. The problem is complicated somewhat by the fact that barometric pressure varies not only at a relatively steady rate with altitude but also quite variably with the weather. The following paragraphs show you how to account for the variabilities of weather in calculating your performance.

Two kinds of altitude are given in the performance graphs, pressure altitude and standard altitude, and neither represents readings which you would normally see on you altimeter. Pressure altitude is an expression of barometric pressure, in feet above sea-level instead of inches of mercury which enables you to use the altimeter both to determine your actual height above sea-level, and to determine barometric pressure for performance purposes. Standard altitude used in the data for range, speed, fuel consumption and the like is pressure altitude corrected to a standard temperature.

In order to find your standard altitude at a given time and place, set the altimeter for a barometric pressure of 29.92. It will then read pressure altitude. Note the outside air temperature. On the Altitude Conversion Chart on page 14 go up the line for your air temperature to the point where it crosses the curving line for your pressure altitude. Then read horizontally across the chart to your density altitude, labeled "Standard Altitude." You must set your altimeter to 29.92 (sea-level standard pressure) in order to remove any correction previously made to it for local barometric pressure. (This correction is necessary when the altimeter is used as a height gage, that is, to determine your distance above the ground. However, when you are determining pressure altitude, barometric pressure compensation will produce an error rather than a correction.) The standard altitude shown in the graphs actually is density altitude at the standard temperature represented by the diagonal line in the conversion chart. However, for all practical purposes, you may ignore the temperature difference and consider density altitude to be standard altitude.

Like the altimeter, your airspeed indicator shows pressure, in this case, the difference between ram air pressure and static ambient barometric pressure which is expressed as miles per hour of indicated air speed. Since variations in both barometric pressure and temperature will affect this pressure differential, and thus the indicated air speed, the data of the graphs is presented in terms of true airspeed.

Converting the data to standard simplifies the calculation of how far you will really go at a given indicated airspeed under actual or predicted conditions. To convert indicated airspeed to true airspeed, determine pressure altitude, indicated airspeed and outside air temperature, then find the true airspeed by multiplying the indicated airspeed by the appropriate factor from the conversion chart of page 14.

Some charts give airspeed as IAS, indicated airspeed, which you read directly from the instrument. In these cases, indicated is preferable to true airspeed, where the performance item (as maneuvering speed, stalling speed, etc.) is affected by barometric pressure in the same proportion as indicated airspeed so that correction is not desirable.

Take-off, landing and climb performance data is contained in Section 5 of the Flight Manual.

Use the Cruise Performance Chart on page 17 and the Fuel Consumption vs. Horsepower Chart on page 16 for arriving at RPM, manifold pressure and fuel pressure settings for cruising flight.

The chart on page 15, Fuel Flow vs. Nozzle Pressure, shows fuel consumption in gallons per hour plotted against fuel pressure at the engine distribution block. You should keep this in mind, and not be alarmed at seeing values of fuel pressure on the fuel pressure gauge, (it reads pressure at the distribution block) which are less than you are accustomed to seeing on fuel pressure gauges which take their reading from the points upstream where the pressures are higher. Knowing these facts, you will now realize that this makes the fuel pressure gauge

**PITTS S-2B  
OWNER'S MANUAL**

GETTING THE MOST FROM YOUR S-2B (cont'd)

a flowmeter, (with the chart on page 15 to help you convert psi to gal/hr.) and is thus an aid in helping you tell if you are using the mixture control properly when you lean to a desired percent power setting. In other words the charts of Cruise Performance, page 17; Fuel Consumption vs. Horsepower, page 16; and Fuel Flow vs. Nozzle Pressure, page 15, used together enable you to set up whatever power setting and fuel mixture you may wish.

PITTS S-2B  
OWNER'S MANUAL

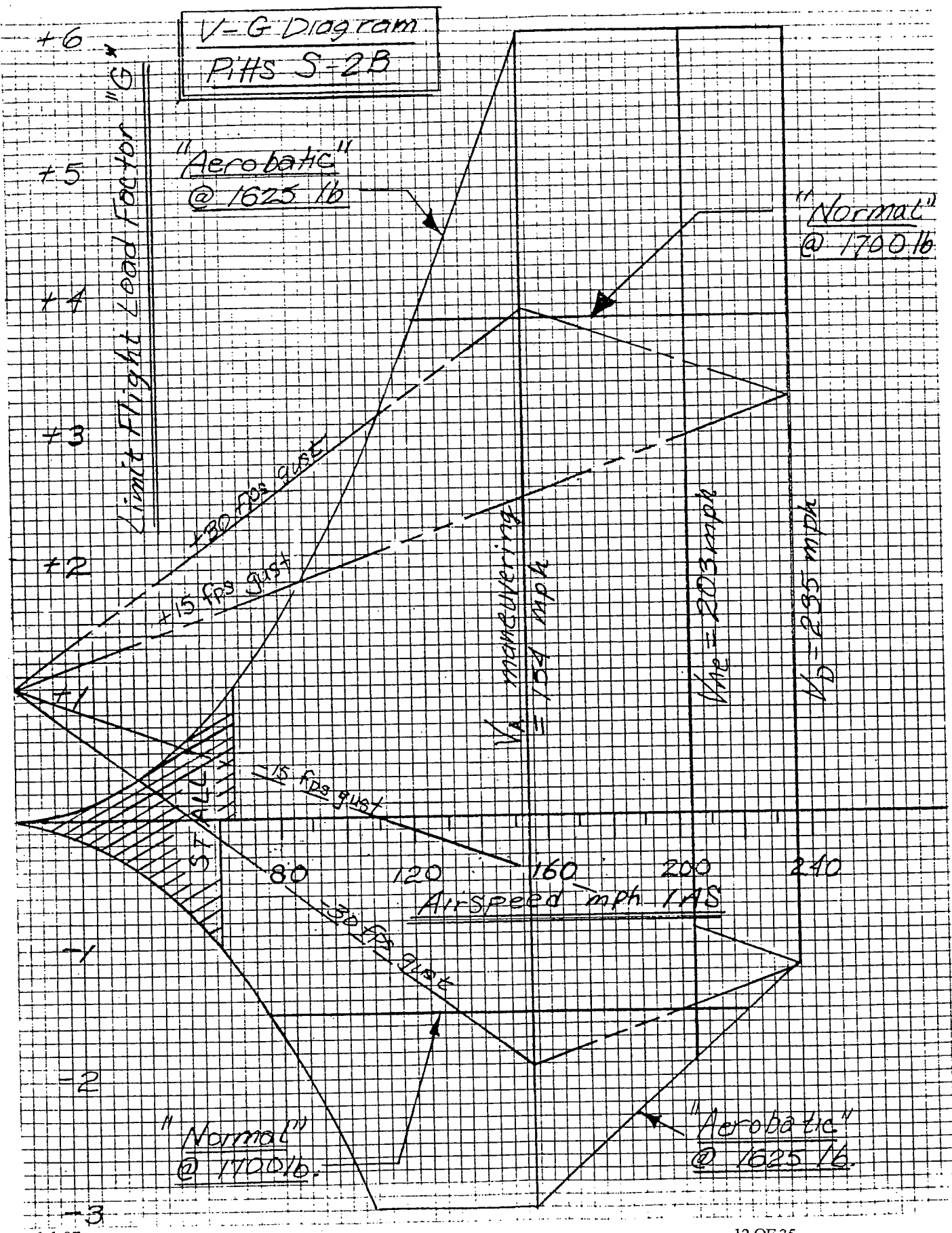

MAX. ENGINE RPM (2700 RPM)

Manifold Pressure  
vs. RPM  
Pitts Model S-2B

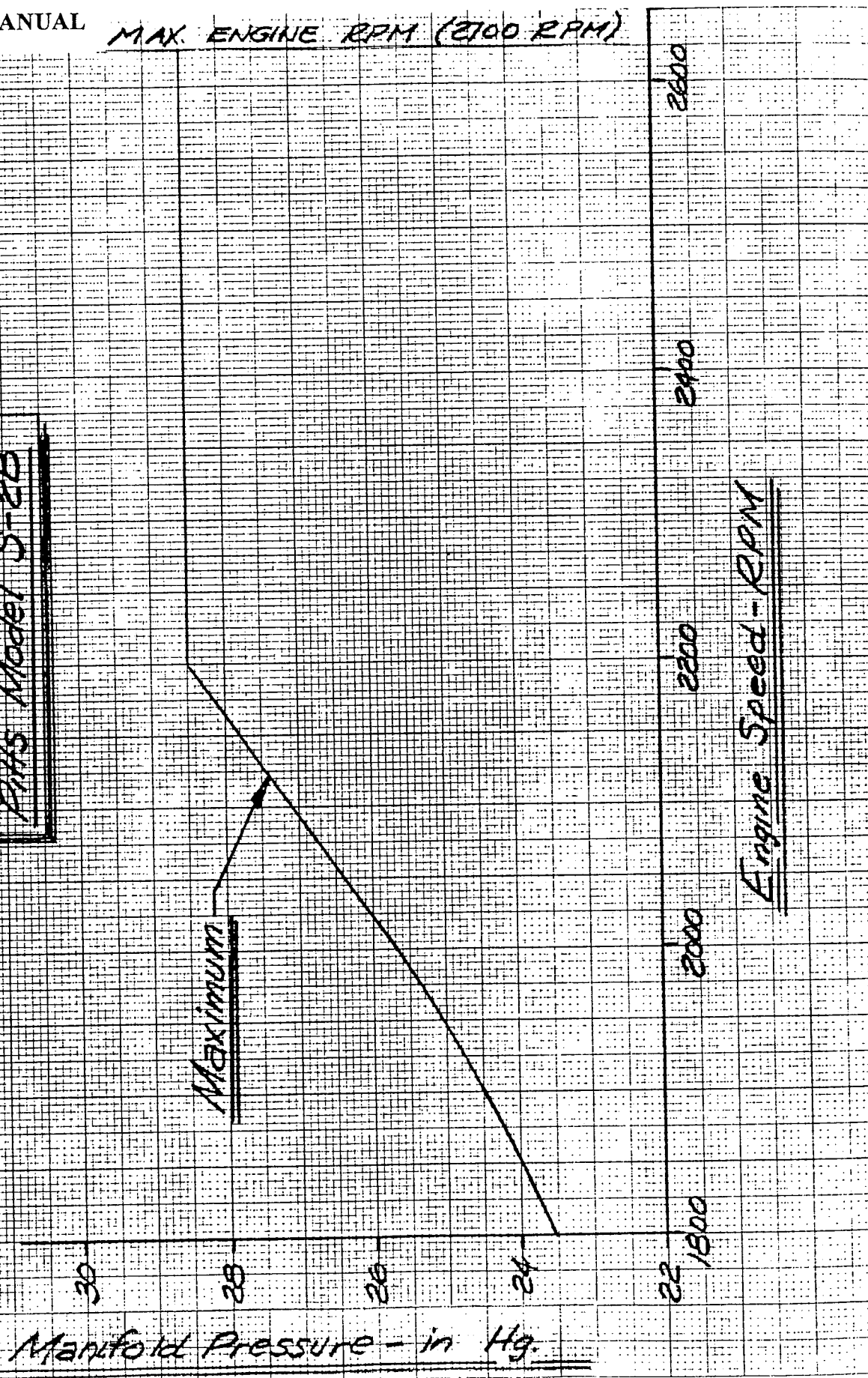

Engine Speed - RPM

Manifold Pressure - in Hg.

# Altitude Conversion

Example: If ambient temp is  $-15^{\circ}\text{C}$  and pressure altitude is 6000 ft, the standard altitude is 4000 ft and  $(1/\sqrt{\sigma})$  is 1.06, and if IAS is 100, TAS is 106

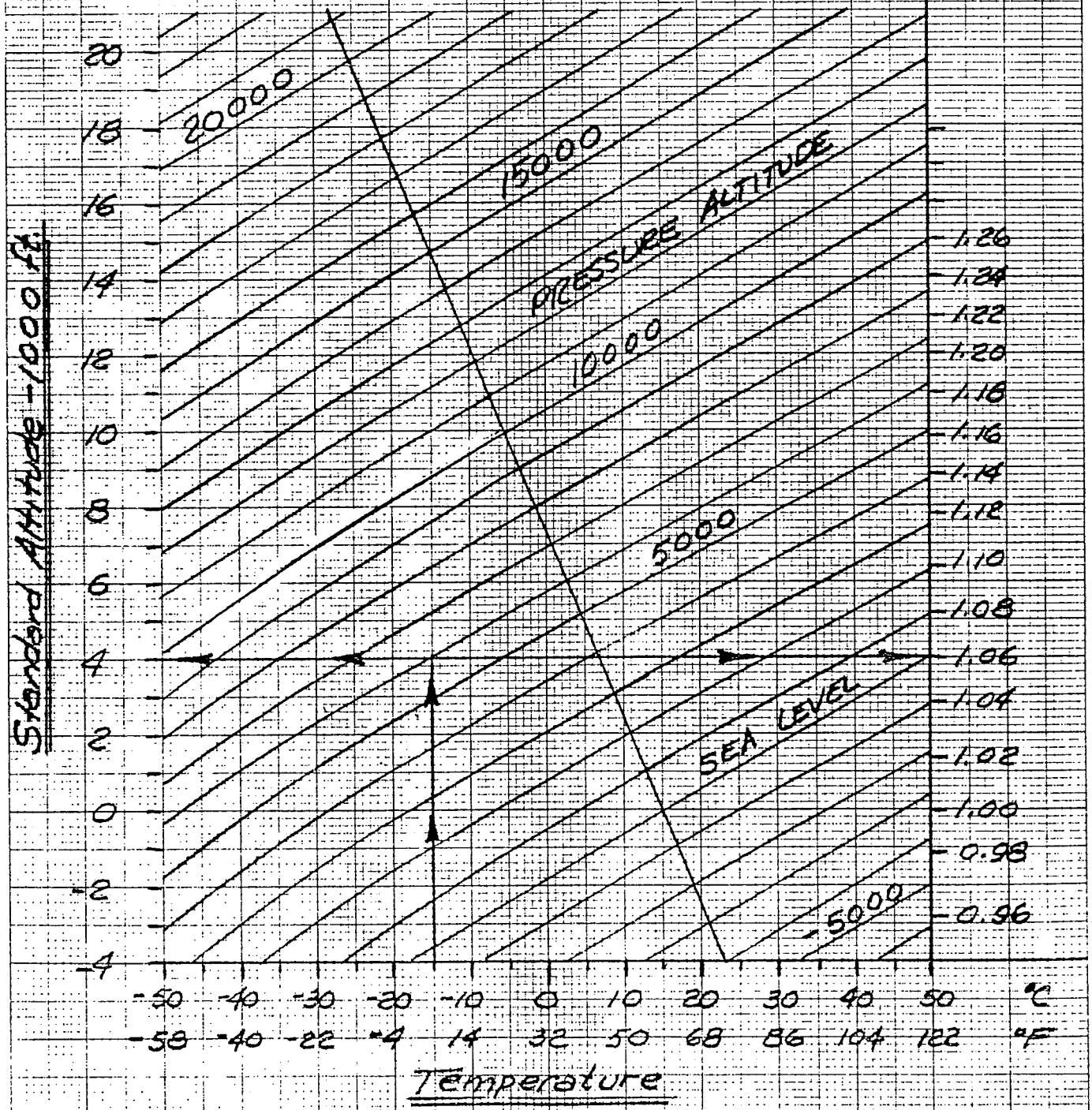

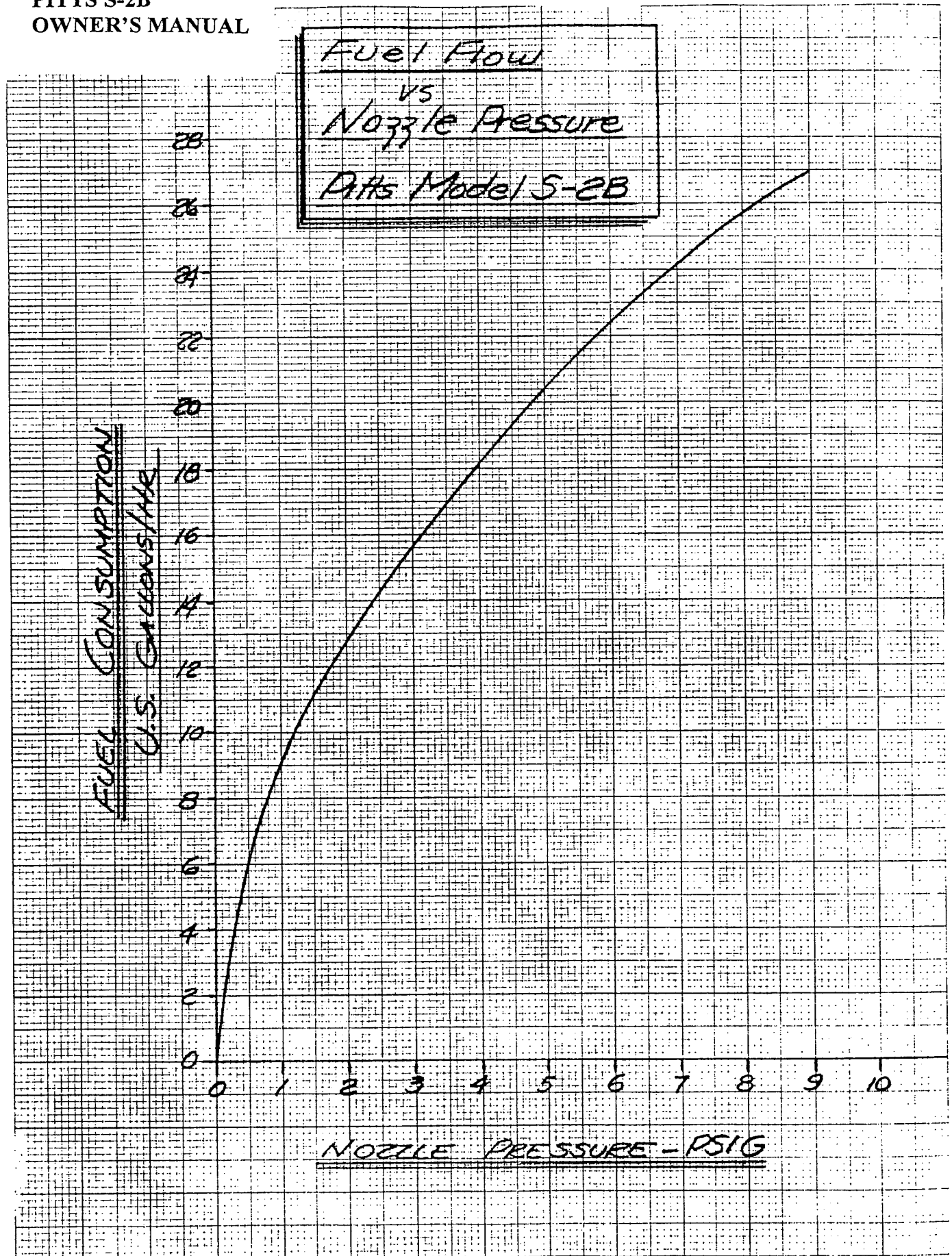



PITTS S-2B  
OWNER'S MANUAL

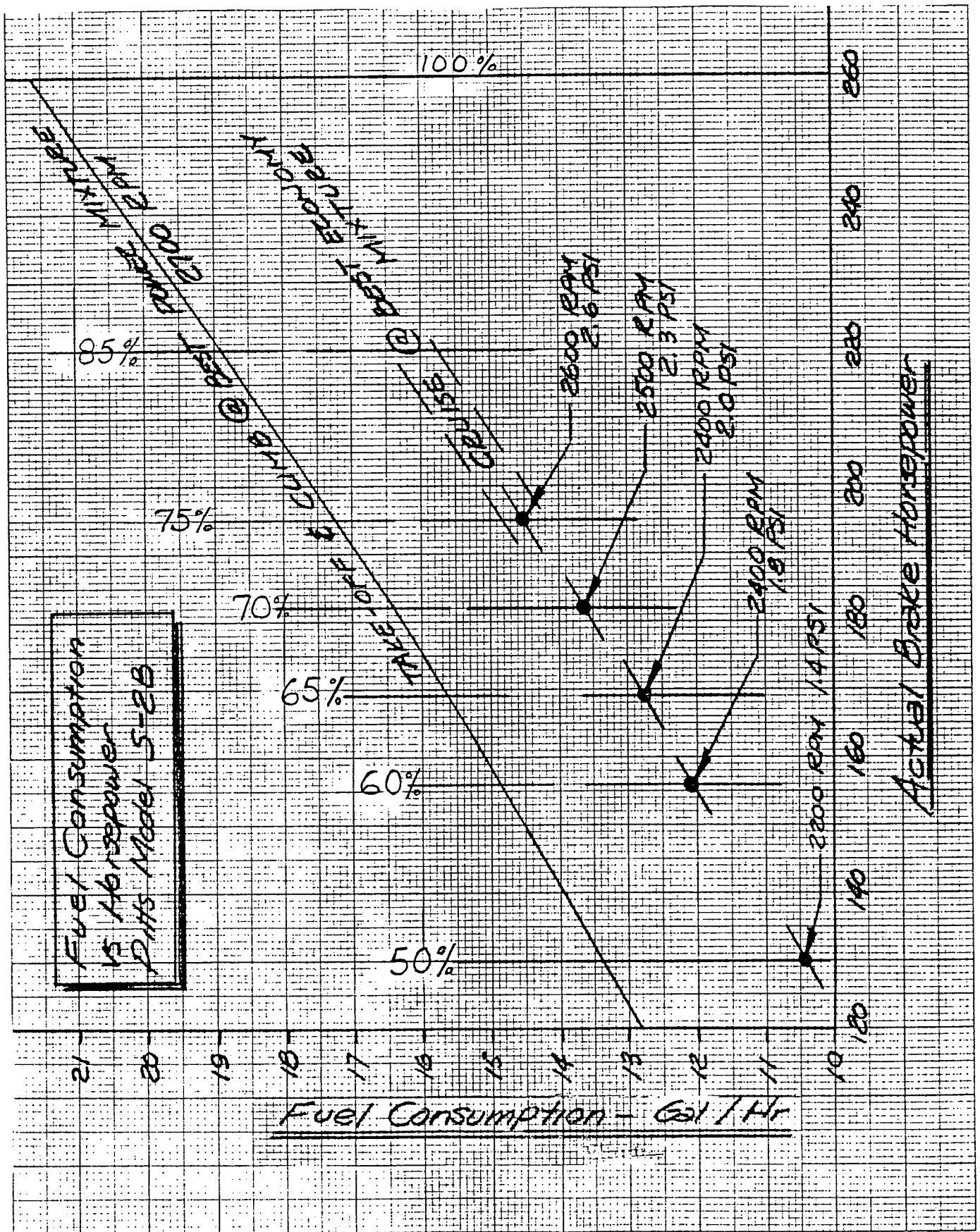

PITTS S-2B  
OWNER'S MANUAL

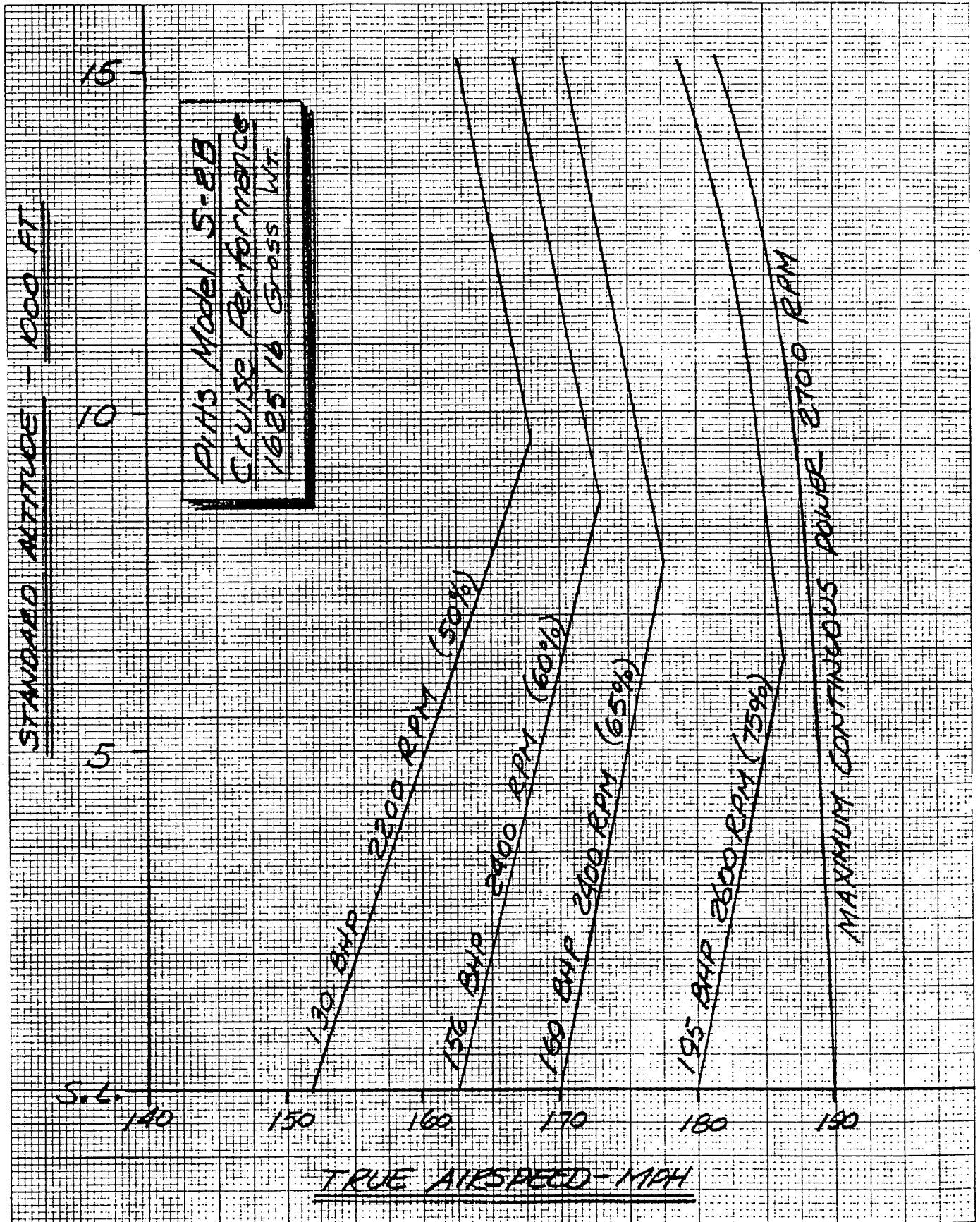

PITTS S-2B  
OWNER'S MANUAL

Maximum Safe  
Crosswind Velocities  
Pitts Model S-2B

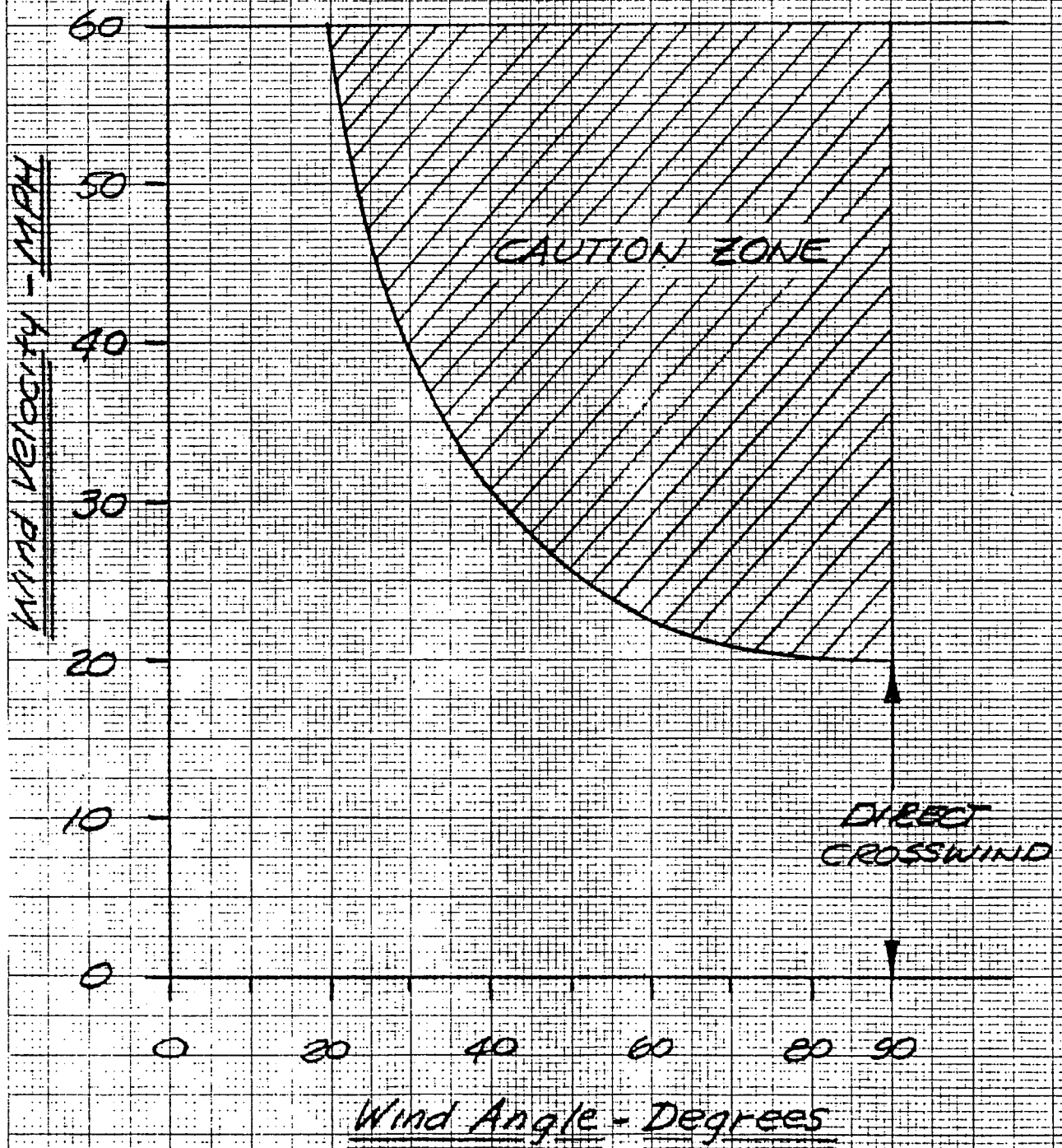

**PITTS S-2B  
OWNER'S MANUAL**

**ERECTION OF THE AIRPLANE**

**FITTING UNDERCARRIAGE**

1. Jack up fuselage front and rear.
2. Assemble port and starboard undercarriage truss and fit to fuselage with main attachment bolts. Safety bolts. To install safety cables see Fig. (1)
3. Fit both shock cords using special stretching tool.
4. Check that shock cords lay evenly.
5. Check that truss rests on bumper block.
6. Connect brake lines and fill brake reservoirs with MIL-H-5606.
7. Install brake units.
8. Bleed brake system.
9. Install wheels.
10. Install wheel fairings.
11. Install truss fairings.

**FIGURE 1 - SAFETY CABLE INSTALLATION**  
Install safety cable as shown to allow 2 1/2" movement of the gear at the aircraft center line. Use 3/16 dia. cable with two nicopress sleeves installed as shown. Squeeze each sleeve 4 times.

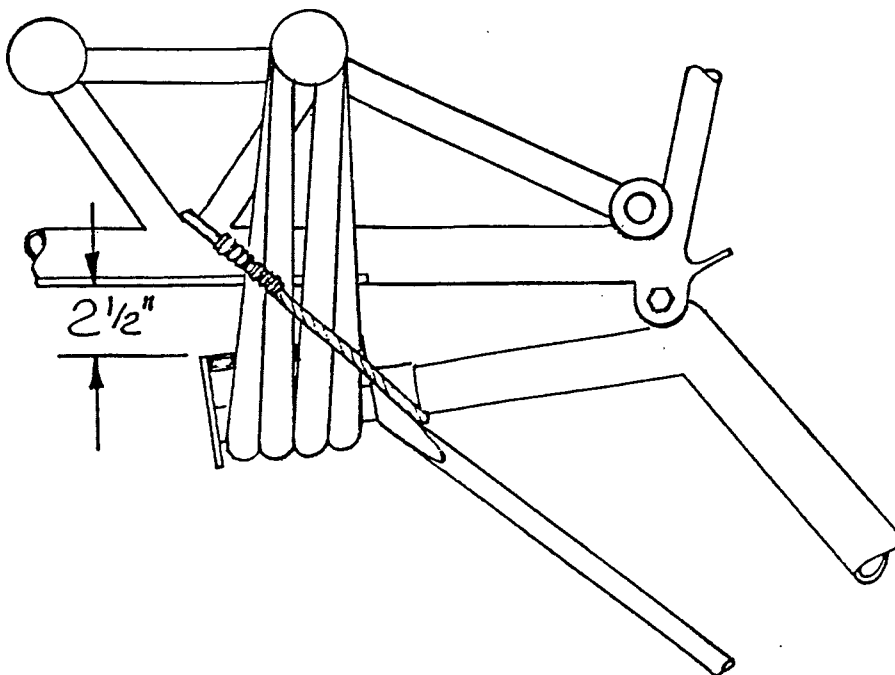

**PITTS S-2B**  
**OWNER'S MANUAL**

TO INSTALL THE WINGS, FOLLOW THESE STEPS IN ORDER

1. Level fuselage fore and aft and laterally by placing an accurate level on the upper longerons in the rear cockpit. Arrange suitable support for the fuselage.
2. Arrange suitable support for the lower wing tips when the wings are installed on the fuselage.
3. Fit lower wings to fuselage and install bolts in root fittings. Support at wing tips. Front bolt AN5-22A. Rear bolt AN4-16A. Nuts AN365-524. AN960-4 or 4L washers as shims between wing spar and fitting if required.
4. Fit upper wing on cabane struts and install bolts. Front bolt AN5-30A. Rear bolt AN6-32A. Nuts AN365.
5. Install interplane struts. Make sure correct number of AN960-416 washers are installed between wing and struts at each point. Always install one AN970-416 large diameter washer next to wing and then the number of AN960-416 washers marked on wing adjacent to the strut attach point.
6. Install landing wires in their proper location as per labels.
7. Install landing wires and tighten evenly left and right to 875 lb. each on tensiometer with no dihedral in upper wing. A tolerance of plus or minus 100 lb. is allowed.
8. Check each wing panel carefully for zero twist. (A maximum of 5 AN960-416 washers may be used at any one strut attachment for rigging.)
9. Attach aileron control tubes to fitting on control column through inspection hole in bottom of fuselage. Replace inspection cover after inspection for security.
10. Install the aileron interconnecting struts. Make sure proper spacer washers are installed between bearing and strut fork to prevent binding or drag.
11. Connect airspeed lines. Check for operation.
12. Connect stall warning switch wires. Check for operation.
13. Inspect each of the 10 preceding operations for completion and safety.
14. Install access plates on wings at flying wire attach points.
15. Install wing root fairings on lower wing.
16. Install fore and aft fairings on each interplane strut.
17. Check ailerons to make sure all four ailerons fair with the wings at the same time.

TAIL UNIT

1. Fit tailplane on stubs and install front and rear attachment bolts.
2. Fit top and bottom streamline wires.
3. Adjust wires until tailplane is horizontal and all hinges are in line. Tension wires (225 lb. to 400 lb.) and set in streamline. Safety bolts and wires. Check safety holes in clevises to assure that wire extends past safety hole.

**PITTS S-2B  
OWNER'S MANUAL**

TAIL UNIT (cont'd)

4. Install elevators and safety hinges.
5. Fit connecting bolts.
6. Connect elevator rod and check for full and free travel.
7. Connect trim tabs and check for full and free travel.
8. Install rudder and safety bolts.
9. Connect rudder cables. Check movement and set up pedals. Safety turnbuckles and bolts.

LEVELING AND RIGGING

The airplane may be leveled fore and aft by placing the level on the top longerons in the rear cockpit area and supporting the tail at a proper height. To level laterally place level across both top longerons in the rear cockpit area.

RIGGING

	INCIDENCE		DIHEDRAL	TOLERANCE
	ROOT	TIP		
UPPER WING	+1.5 °	+1.5 °	0 °	±.5 °
LOWER WING	+1.5 °	+1.5 °	+3 °	±.5 °
STABILIZER	+2.5 °	+2.5 °	0 °	±.5 °

CONTROL SURFACE TRAVELS

	UP	DOWN	RIGHT	LEFT	TOLERANCE
AILERON	+25 °	+25 °			+2 °
RUDDER			+30 °	+30 °	±.75 °
ELEVATOR	+27 °	+27 °			±.75 °
ELEVATOR TAB (Elev. Neut)	+7 °	+19 °			±2 °

TIE ROD TENSIONS

	SIZE	MIN.	MAX.
INTERNAL WING WIRES	10-32	200 lb.	350 lb.
WING FLYING (streamline)	5/16-24	750 lb.	1000 lb.
TAIL BRACE (streamline)	1/4-28	225 lb.	400 lb.

BOLT TORQUES

Unless otherwise stated standard torque values for the bolts should be used as per AC 43.13. Take care when tightening bolts installed in wood where there is not a steel bushing. Do not tighten the bolt such that the wood is crushed.

# PITTS S-2B OWNER'S MANUAL

## SERVICE AND GENERAL MAINTENANCE

### FUEL

The Lycoming AEIO-540-D4A5 engine installed in the S-2B uses 100 grade or 100LL grade aviation gasoline. Tank capacity is 29 U.S. gallons maximum, 28 gallons usable in normal flight.

### OIL

The oil capacity of the Lycoming AEIO-450-D4A5 engine is 12 quarts. It is recommended that the engine oil be changed every 50 flying hours or more often in adverse conditions. The following grades of oil are recommended for the specified average ambient temperatures:

ABOVE 60 ° F	SAE 50
30 ° F TO 90 ° F	SAE 40
0 ° F TO 70 ° F	SAE 30
BELOW 10 ° F	SAE 20

Good quality ashless dispersant oil should be used, except for the first 50 hours of new engine operation when a straight mineral oil is recommended.

### BATTERY

A 12 volt, 28 ampere hour Gel/Cell or Concorde RG-25 battery is standard equipment. The battery should be maintained in a charged condition at all times.

If the Gel/Cell battery requires recharging, recharge at a maximum initial charge rate of four amps, and a final charge rate of two amps. The master switch should be off when charging.

The Concorde RG-25 battery should be charged with a constant potential or constant voltage charger regulated at 2.35 volts per cell. (14.1 volts for a 12 volt battery.)

### WINDSHIELDS

The windshield and canopy on the S-2B is made of Plexiglas. In order to keep it clean, the following procedure is recommended:

1. Flush with clear water to dislodge dirt, mud, etc.
2. Clean with an aircraft grade Plexiglas windshield cleaner, using a soft cloth.
3. Scratches may be removed by polishing with jeweler's rouge. Where available, Mac's Dynamite Cleaner, obtainable from most auto supply stores is an excellent mild abrasive for polishing out small scratches.

### BRAKE SYSTEM

The brake system is filled with a petroleum base hydraulic fluid complying with MIL-H-5606. If it is necessary to add fluid to the system, do so as follows:

1. Remove filler plugs from upper ends of master cylinders.
2. Fill with correct hydraulic fluid.
3. Replace filler plugs.
4. Check brake system for proper operation.

When it is necessary to refill or to bleed the brake system to remove air, follow this procedure:

1. Remove filler plugs from upper ends of master cylinders.
2. Loosen bleeder screw on brake unit at wheel and drain system.

## PITTS S-2B OWNER'S MANUAL

### SERVICE AND GENERAL MAINTENANCE (cont'd)

3. Onto the loosened bleeder screw, insert brake bleeder hose, which is fastened to a pump-type pressure oil can filled with correct hydraulic fluid.
4. Fill the system from the bottom up using the pump-type pressure oil can.
5. When master cylinder is full, tighten brake bleeder screw after removing bleeder hose.
6. Reinstall filler plug in master cylinder.
7. Check system for proper operation.

No adjustment of brakes clearances is necessary on the S-2B. If brake linings become worn they may be replaced by removing two bolts fastening the brake units together, removing the lining backing plates and replacing the linings.

### TIRES

For maximum service keep the 5.00 x 5 Type III 6 ply rating tube-type tires inflated to 35 pounds per square inch.

The tires can be removed from the wheels by first deflating the tubes, then removing the wheel through-bolts, allowing the wheel halves to be separated.

### FABRIC

The fabric covering material of the S-2B is 2.7 oz. per yard dacron with 3.7 oz. used on the fixed surface of the wing. The filler and finish on all fabric surfaces is non tautening butyrate dope or polyurethane. The fabric covering may be repaired or replaced by standard accepted methods for fabric repair or replacement.

### METAL FINISH

All cowlings, fairings, etc. are finished in chromated synthetic enamel. It is necessary to etch the metal parts prior to application of the normal finish.

### LANDING GEAR

The main landing gear is fabricated of 4130 N tubing. There are no heat treated parts in the main gear. Energy is absorbed by four 1280 HD shock rings and a safety cable is provided in the event the shock rings fail.

The tail gear consists of a Maule SFS-1-4 steerable swivel tail wheel assembly, a flat leaf spring for energy absorption and two steering spring assemblies.

The landing gear should be serviced each 100 hours.

### FUSELAGE

The fuselage of the S-2B is of conventional welded 4130 N tube construction. There are no specially heat treated members in the fuselage. The entire fuselage frame assembly is sandblasted and primed with an epoxy primer for protection against corrosion.

### TAIL ASSEMBLY

The entire tail assembly is constructed of welded 4130 N tube and sheet and is protected in the same manner as the fuselage.



**PITTS S-2B  
OWNER'S MANUAL**

SERVICE AND GENERAL MAINTENANCE (cont'd)

CONTROL SYSTEM

Extensive use of ball bearings in the control system assures smooth trouble free operation and minimum wear. Keep all jam nuts and all bolts in rod end bearings tight. The inner race of all ball bearings must be tight and not allowed to rotate on the through bolt.

ENGINE

The engine installed on your S-2B is the Textron Lycoming AEIO-540-D4A5 direct drive, horizontally opposed, 6 cylinder, with fuel injection and inverted oil system. For specific requirements for periodic inspections, maintenance procedures, trouble-shooting, and installation and storage refer to the Textron Lycoming Operator's Manual 60297-21.

PROPELLER

Your S-2B is equipped with one of three propeller types:

1. Hartzell HC-C2YR-4CF/FC8477-4, constant speed, aluminum alloy two-blade propeller. For specific requirements for periodic inspections, maintenance procedures, operating instructions, and installation refer to Hartzell Propeller Owner's Manual & Log Book Manual No. 115N.
2. MT Propeller MTV-9-B-C/C190-18a, constant speed, composite three-blade propeller. For specific requirements for periodic inspections, maintenance procedures, operating instruction, and installation refer to MT Propeller Operation and Installation Manual NO. E-124.
3. Hartzell HC-C3YR-1A/7690C, constant speed and hydraulically actuated three-blade propeller. This propeller differs from the others in that oil pressure is used to increase blade angle. As a result any loss of oil pressure results in a decrease in blade angle - to fine pitch. An accumulator is fitted with this propeller to maintain oil pressure during acrobatic flight so that there is no tendency for the propeller to overspeed. For specific requirements for periodic inspections, maintenance procedures, operating instructions, and installation refer to Hartzell Propeller Owner's Manual & Log Book Manual No. 115N.

**PITTS S-2B  
OWNER'S MANUAL**

**MAINTENANCE SCHEDULE**

This maintenance schedule is considered to be adequate for aircraft used normally and for aerobatic use and is to be used in conjunction with the FAA Approved Flight Manual on aircraft certified in this category.

**NOTE:**

On aircraft used for aerobatic work it is important that a good liaison with the pilot is maintained in order to assess the loads imposed and, therefore, the depth of maintenance to be carried out.

**DAILY INSPECTION**

1. Check aircraft documents and ascertain if there are any reported defects.
2. Inspect aircraft generally for external signs of damage, particularly under lower wing, under fuselage, and under tail.
3. Check control surfaces for full and free travel. Check that there is no excessive backlash in the aileron or elevator system. Ensure that there is tension in the rudder circuit.
4. Check operation of elevator trim.
5. Carry out a general assessment of tension of wing streamline wire. Investigate any uneven tension or change of tension.
6. Check tension of tailplane bracing wire.
7. Check cockpits for freedom from foreign matter.
8. Check condition of safety harness.
9. Check inside of wheel firings for accumulation of mud.
10. Check that aircraft stands level and rock from side to side to check tension of U/C shock chords.
11. Check tires for condition. Inflate to 35 PSI.
12. Check tail wheel unit and springs for condition.
13. Check brake units for condition and signs of fluid leakage.
14. Visually check instruments for condition and zero.
15. Check pitot head and static holes for freedom.
16. Check operation of stall warning sensor with master switch on.
17. Open engine cowling and inspect engine installation visually for leaks of oil and fuel.
18. Check oil level and security of oil filler.
19. Check exhaust gaskets and exhaust nuts. See that exhaust joints are free to move.
20. Check that HT leads are not contacting exhaust pipes.

**PITTS S-2B**  
**OWNER'S MANUAL**  
DAILY INSPECTION (cont'd)

21. Visually check engine mounting for condition.
22. Check fuel drains.
23. Check cowling attachments and fastenings.
24. Check spinner for security and condition.
25. Check propeller blades for freedom from damage.
26. Check fabric covering for signs of internal damage or distortion.
27. Check fuel and oil contents.

GROUND RUNNING AND ENGINE TEST

STARTING

1. See that switches are off.
2. Pull propeller through 8 compressions to clear any oil accumulated.
3. Make sure that canopy is locked.
4. Select air intake to normal position.
5. Set propeller control to high RPM (low pitch).
6. Select fuel ON.
7. Set throttle to ¼ open.
8. Set mixture to full rich.
9. Switch fuel booster pump to ON (2 to 3 seconds maximum).
10. Set mixture to idle cut off.
11. Crank engine with starter.
12. When engine fires, move mixture control slowly to full rich.
13. Check oil pressure on start up.

WARM UP

1. Head aircraft into wind.
2. Keep mixture full rich.
3. Keep propeller in low pitch.
4. Warm up at approximately 1000-1200 RPM.

**PITTS S-2B**  
**OWNER'S MANUAL**

WARM UP (cont'd)

5. Do not exceed 2200 PRM.

NOTE: Hot idle oil pressure 25 PSI MIN.

6. Check oil pressure in green arc, oil temperature in green arc, and mixture: full rich.
7. Set throttle 1700 RPM and move governor control through full range and return to low pitch. Check operation of propeller.
8. Check magnetos with propeller at low pitch and throttle set to give 2200 RPM.
9. Check magnetos individually for drop in RPM, normal drop is 100 RPM, but up to 175 is acceptable if engine operation remains smooth.
10. Check fuel pressure, gauge shows increased pressure with increase in RPM.
11. Check full throttle RPM (not to exceed 2700).

STOPPING

1. Close throttle.
2. Set mixture control to idle cut off.
3. Put master switch off.
4. Turn off ignition.

**PITTS S-2B**  
**OWNER'S MANUAL**  
50 HOUR INSPECTION

GENERAL:

1. The satisfactory external condition of the aircraft, especially wing tips, propeller, empennage extremities, fuselage belly and under wing surfaces.
2. Check that all cowlings, panels and spinner are secure and check condition generally.
3. Tire pressure (35 PSI) and condition of tires, i.e. free from cuts, fractures, undue wear, tire creep. Brake units free from fluid leaks and check brake pads for wear.
4. Check action of undercarriage by gently rocking the aircraft laterally. Check attachment bolts for wear. Check shock cords for condition.
5. Check tail wheel assembly and leaf springs for condition and steering action from rudder. Lubricate as required.
6. Remove any control surface locking devices and check the action of all flying controls for freedom and correct movement. Lubricate all hinges.
7. Check security of pitot head and mountings and orifices for obstructions.
8. Check all control surface hinges are free and undamaged.
9. Check windshields and covers for condition and security.
10. Harnesses in good working order.
11. Battery and terminals secure.
12. Electrical systems functioning. Check all circuit breakers.
13. Check fuel tank and lines for security and lack of leaks, and vents clear. Clean fuel filter.
14. Check fuel valve and gauge for correct action.
15. Check fuel drains for water or foreign matter.
16. Check oil level in engine sump for condition and change oil.
17. Check for obvious signs of leakage of oil, fuel, or exhaust gasses.
18. Check attachment of engine mount to engine.
19. Check engine controls for condition, action and correct movement.
20. Check that there are no loose items that can foul the controls.
21. Check safety straps and attachments for condition and security and lock for action and lightly lubricate.
22. Clear all drain and vent holes.
23. Check seat and attachments for security. Check condition and security of floorboards in cockpit.

## **PITTS S-2B OWNER'S MANUAL**

### 50 HOUR INSPECTION (cont'd)

24. Check cockpit for oil soakage on fabric. Check wheel fairings for condition and security.
25. Check engine firewall for condition.
26. Check engine mount for condition and security, especially at attachments to firewall.
27. Clean out cockpit and aft fuselage if necessary.
28. Check cowlings for condition and security.
29. Check fuselage in vicinity of undercarriage legs and inspect. Inspect undercarriage mounting and surrounding structure for condition.
30. Inspect rear and main spar carry-through tubes in fuselage.

### WINGS:

1. Check fabric coverings for condition and possible damage from stones, etc.
2. Check leading edge for condition or damage.
3. Check wing tips for condition.
4. Check ribs and trailing edge for damage, security or warping. Inspect for damage in region of walk and cockpit entrance.
5. Check main and rear spar attachments to fuselage for condition and signs of movement, or slackness of bolts.
6. Check rib lacing for condition.
7. Clear all vent holes.
8. Clean and check flying and landing wires for nicks and bends.
9. Check tension of wing rigging wires.

### UNDERCARRIAGE:

1. With aircraft at rest on wheels, check that aircraft stands level and bungees are in good condition.
2. Check tail wheel leaf springs for stretching or distortion.
3. Jack up aircraft with wheels clear of ground. Remove wheels for servicing of brakes.
4. Check tailwheel assembly for security of attachment to springs and fuselage. Lubricate as required.
5. Check tailwheel tire, wheel bearings, pivot, actuating levers and coil springs for condition and wear. Lubricate wheel bearings and fork pivot.
6. Check main undercarriage bolts for wear and lubricate.

**PITTS S-2B**  
**OWNER'S MANUAL**

50 HOUR INSPECTION (cont'd)

7. Check tires for condition and pressure 35 PSI. Check tires for "creep".
8. Check wheel bearings and brakes for freedom and correct operation.
9. Check brake system for leaks and top up reservoirs if necessary.  
Refit wheels.
10. Inspect axle tube elbow for cracks at weld.

TAILPLANE:

1. Check tailplane main attachments for security and condition.
2. Carry out general inspection, especially at junction of tailplane and fuselage. Remove stern fuselage inspection panels to complete this inspection.
3. Clear vent holes.
4. Check rudder and elevator hinges.

FLYING CONTROLS:

1. Check all control surfaces for play in hinges and freedom of movement.
2. Check all controls for correct and full travel.
3. Check rudder cables for correct tension, then renew rudder pedal return springs, if cables are slack. Check cable for condition, particularly in the vicinity of fairleads.
4. Check fairleads and rubbing blocks for security and wear. Check push-pull rod adjustment locknuts for security and self aligning bearings for full movement.
5. Check all control surfaces for damage or trailing edge warp. Check ribs and structure for security, particularly in vicinity of wing walk.
6. Check fabric condition of all surfaces and clear vent holes. Check rib lacing and condition of surfaces.
7. Check rudder pedals, control column, torque shaft, and push-pull rod bearings for wear and security.
8. Check action of trim and condition of operating cable, especially in vicinity of trim control horn. Lubricate.
9. Carry out full lubrication schedule.
10. Check trim operating mechanism for wear.

INSTRUMENTS AND SYSTEMS:

1. Check pitot head for condition and security, also static holes.
2. Check all lines at instrument panel mountings.
3. Check all flexible lines for condition and security and lack of kinks at bends.

## **PITTS S-2B OWNER'S MANUAL**

### 50 HOUR INSPECTION (cont'd)

4. Check instruments for correct action.
5. Lubricate RPM gauge tachometer drive.
6. Check compass and mountings for security.
7. Check compass condition i.e., glass and freedom from leaks.
8. Check electrical system for condition and functioning, and wiring condition and security. Check all circuit breakers.
9. Check stall warning system for condition and functioning.
10. Check condition of instrument panel.

### FUEL SYSTEM:

1. Check fuel tanks and straps for security and condition.
2. Check fuel valve for correct and free operation and signs of fuel leakage.
3. Check attachment of fuel lines to tanks for distortion or damage.
4. Check fuel tank venting.
5. Check fuel gauges for correct operation and damage.
6. Remove fuel filter for inspection of contents and cleaning and replace.
7. Check fuel tanks for water.

### ELECTRONICS:

1. Check all circuit breakers for security and operation.
2. Check all circuits for functioning.
3. Check all wiring and all terminals for condition and security.
4. Check stall warning sensor.
5. Check battery leads and mounting for security and condition.
6. Check radio and antenna (if installed) for security.

### FINAL ACTIONS:

1. Clean aircraft inside and out. Check for tools left in cockpit and rear fuselage.
2. Check that articles such as seat and upholstery are secure and not likely to foul controls.
3. Check condition of windshield.



# PITTS S-2B OWNER'S MANUAL

## 50 HOUR INSPECTION (cont'd)

4. Carry out engine run up and taxi tests.

## 100 HOUR INSPECTION:

Repeat 50 hour inspection items, plus the following:

1. Remove all upholstery, seats and panels as necessary for inspection of the structure. Thoroughly inspect the upper longerons for cracks in the region just aft of the welds attaching the rear cabane struts (ref. SB24).
2. Remove wheels, clean brake discs, linings, and operating gear.  
Replace wheels and check brakes.
3. Check rudder cables for wear, especially in the vicinity of fairleads.
4. Inspect control column and trim bearings for cleanliness and lubrication.
5. Check instrument lines, drain as required, and test for leaks.  
Reconnect and test pitot static instruments against suitable standard.
6. Carry out electrical insulation tests if considered necessary.
7. Swing compass and check compass for condition.
8. Carry out 100 hour inspection on engine as laid down in Lycoming hand book.
9. Inspect propeller for condition of blades.
10. Check spinner for tightness and freedom from cracks.

## 1000 HOUR INSPECTION

Repeat 50 hour and 100 hour inspection and carry out the following extra items:

1. Check wing main attachment bolts for condition of bolts, fittings and condition of holes through fittings.  
Refit after inspection.
2. Inspect spars for condition in vicinity of inspection panels.
3. Remove control surfaces and inspect hinges for condition. Refit after inspection.
4. Remove rudder cables to control horn attachment bolts for inspection of bolts and holes. Wear in holes and bolts in excess of .016" requires renewal of component. Refit after inspection.
5. Rig and check all controls. Carry out duplicate 100 hour inspection.
6. Clean and inspect aft section of fuselage.
7. Remove battery for inspection and servicing, recharging and test.  
Refit after inspection.
8. Check tension of engine mount main attachment bolts.
9. Check and record wing and empennage rigging.

**PITTS S-2B**  
**OWNER'S MANUAL**  
1000 HOUR INSPECTION (cont'd)

10. Carry out structure condition and welded joint inspection on complete aircraft structure.
11. Carry out fabric and rib lacing condition check on complete aircraft.
12. Check fuel tanks and lines for leaks and condition. Carry out fuel flow checks on complete system for ample flow and contamination.

HEAVY LANDING INSPECTION

A landing heavier than normal could cause the tires and undercarriage to compress abnormally and create serious stresses throughout the aircraft structure. Further, a heavy landing on one wheel or with drift could be even more serious. Any form of heavy landing should be reported before the aircraft is used again and the necessary inspection carried out on the aircraft by a suitable inspection organization or licensed mechanic. The following Inspection Schedule can act as a guide.

1. With aircraft static, check the aircraft stands level.
2. Check outer and inner struts of undercarriage truss for bowing or dents.
3. Check wheel axles for correct alignment and weld on elbow for signs of failure.
4. Check action of undercarriage by gently lifting on each interplane strut. (Do not do this at wing tips as severe stressing of the spars could result.)
5. Check tires for signs of "creep".
6. Remove fairing panels from top and bottom of interplane struts. Inspect strut welds and strut attachment for signs of overload and bolts for distortion.
7. Remove fuselage side panels and inspect fuselage structure for bowed tubes, dented tubes, tubes with raised ridge, cracks or deformation around welds and damaged fittings.

PITTS S-2B  
OWNER'S MANUAL

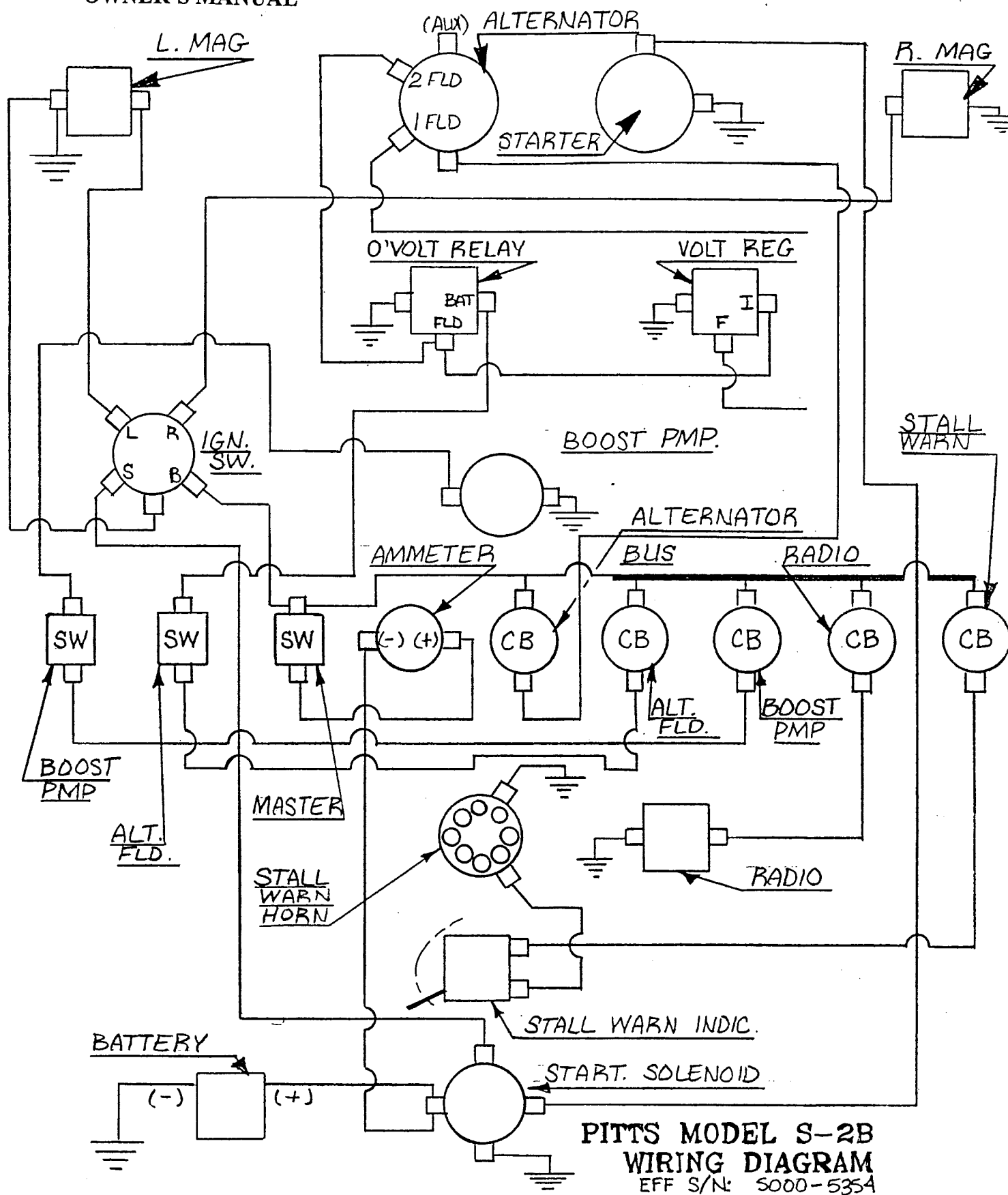

PITTS MODEL S-2B  
WIRING DIAGRAM  
EFF S/N: 5000-5354

PITTS S-2B  
OWNER'S MANUAL

PITTS MODEL S-2B  
WIRING DIAGRAM  
EFF S/N: 5355 & UP

