



PA-30 AND PA-39  
***TWIN COMANCHE***

PARTS CATALOG

CARD 1 OF 2

PA-30

PA-39

**PIPER AIRCRAFT CORPORATION**

(PART NUMBER 753 646)

**1 A1**  
Island Enterprises

# PIPER PARTS CATALOG

## AEROFICHE EXPLANATION

The Parts Catalog information incorporated in this set of Aerofiche cards has been arranged in accordance with the general specifications of Aerofiche adopted by the General Aircraft Manufacturer's Association.

### Conversion of Aerofiche alpha/numeric code numbers:

First number is the Aerofiche card identifier.

Letter is the horizontal line reference per card.

Second number is the vertical line reference per card.

Example: 2J16=Aerofiche card number two of given set. Grid location J16

To aid in locating the various sections and related information desired, the following is provided:

A complete Catalog Table of Contents is given at Grid 1A7 of Aerofiche card number 1 of this set. Each additional card in this set will have a Table of Contents for all sections on that particular card. This table will start at Grid A3.

## REVISIONS

The information compiled in this Aerofiche Parts Catalog will be kept current by revisions distributed periodically. These revisions will supersede all previous revisions and will be complete Aerofiche card replacements and shall supersede Aerofiche cards of the same number in the set.

Current Revisions to the PA-30 and PA-39 Parts Catalog issued February 1973 are as follows:

753 646 (PR770211).....	Dated February 1977
753 646 (PR800514).....	Dated May 1980
753 646 (PR820910).....	Dated September 1982

NOTE: Refer to the last card of the Piper - Parts Price List - Aerofiche for a check list of current revision dates and card effectivities for this parts catalog

# INTRODUCTION

This illustrated Parts Catalog is designed to provide simple but positive identification of replacement parts for the Piper "TWIN COMANCHE" Models PA-30 and PA-39, manufactured by the Piper Aircraft Corporation of Lock Haven, Pennsylvania.

**NOTE: UNDER NO CIRCUMSTANCES SHALL THIS CATALOG BE USED FOR RIGGING AND INSTALLATION PURPOSES.**

It is suggested that this catalog be thoroughly studied to determine its arrangement prior to its utilization.

1. The catalog is divided into ten (10) major sections described as follows:
  - a. Sections I to IX inclusive contains all replacement parts for the completed airplane. Each section is subdivided and each division includes an illustration and a parts listing.
  - b. Section X is the Miscellaneous Group. This group includes a listing of the Optional Equipment Kits, Repair Kits and Special Tools.
2. The following is a brief explanation of the columns in the parts listing:
  - a. The "FIGURE AND INDEX" column indicates the illustration figure number and its part index number. Example: (2-1), the 2 is the figure number and the 1 is the index number. The figure number appears only at the top of each parts listing page or at the beginning of each new parts listing.
  - b. The "PART NUMBER" column contains the identifying number of the replacement part and this number must be shown on all Parts Orders.
  - c. The "CODE" column is for the purpose of indicating special uses of the part. An explanation of the letter code used is shown below each listing.
  - d. The "NOMENCLATURE" column indicates the part name. This name must be shown on all Parts Orders.
  - e. The "NO. REQ." (Number Required) column represents the total quantity of parts used per aircraft per figure when the part is not indented and the quantity of parts used per assembly when the part is indented. The symbol "AR" listed in this column means "As Required."
  - f. The "SERIAL NUMBERS AFFECTED" column indicates the part application by airplane serial number.

Indentation Example: Indentations of listings in the "Nomenclature column" indicates "assemblies" and "components" or "parts," in order of their indentations.

EXAMPLE					
Figure and Index Number	Part Number	Code	NOMENCLATURE	No. Req.	SERIAL NUMBERS AFFECTED
			DOOR ASSEMBLY - Baggage compartment	1	
			• FRAME ASSEMBLY - Baggage compartment door	1	
			• • HINGE ASSEMBLY - Baggage door	1	
			• • CLIP - Baggage door spring	1	

This listing is interpreted as follows:

If the DOOR ASSEMBLY (not indented) is ordered, it will include the three items listed under that item.

If the FRAME ASSEMBLY (indented one space) is ordered, it will include the two items listed under the subassembly

If you want only a HINGE ASSEMBLY or CLIP, you order only that item.

3. The "ATTACHING PARTS" such as nuts, bolts, screws, etc., that are available as commercial hardware items, are not generally supplied by the Piper Aircraft Corporation. The catalog lists, for your convenience, those attaching parts required for main assemblies and installations. The identifying number for these parts appears after the part name.
4. All items of Optional Equipment are contained in the parts list in their proper sequence and sections. These items were not marked optional, since they are fully identified by their descriptions.



HOW TO IDENTIFY A PART  
IF YOU KNOW WHAT IT LOOKS LIKE  
AND KNOW WHERE IT IS LOCATED

- (1) Refer to Figure 1 to determine the section number in which the part is used.
- (2) Refer to the Table of Contents and locate the section. Note the figure numbers that illustrate the various subgroups of this main section.
  - (a) Select the figure title you think might contain the part you wish to identify and turn to the grid (page) specified.
- (3) Find the part on the illustration and note the index number.

NOTE: If you don't find the part on this illustration, try another figure in this group.

- (4) Refer to the "Figure and Index Number" in the Parts Listing for complete description of the part.

HOW TO ORDER PARTS

In ordering parts for your Piper Airplanes, observe the following instructions which will aid in your getting the right parts required without delay.

- a. Place your order with the distributor or dealer for your territory, since parts are available only through our distributor organization.
- b. Always specify the model and serial number of your airplane.
- c. Always specify part number, name, type and quantity required.
- d. Specify the method of shipment, freight, express, parcel post, air express, air freight or air parcel post.

Where the nature of the shipment requires it or when no instructions are given, we reserve the right to ship the most suitable way.

GENERAL INFORMATION

a. Shortages

All orders are checked and rechecked before leaving our Shipping Department. A packing slip is enclosed with the shipment and claims for errors or shortages must be made within three days after receipt of orders.

b. Returned Goods

No material should be returned to us without first securing our written permission. Material sent in without notice will be held at the owner's risk for thirty (30) days and will then be disposed of as we see fit.

Transportation charges must be PREPAID on returned goods or the shipment will be refused.

c. Transportation Liabilities

The Piper Aircraft Corporation cannot be held liable for damages to parts in transit from the factory. If a shipment is received in a damaged condition, have the delivery man or Transportation Company make a notation of the damage and file your claim with the Carrier. In case of concealed damage, do not attempt to remove the part from the shipping container or endeavor to repair the damage, but call the Carrier and have his Claim Agent inspect the damage before filing your claim with the Carrier.



## PA-30 AND PA-39 SERIAL NUMBERS INFORMATION

The following information should be kept in mind when ordering from this catalog:

- a. The serial numbers of the aircraft covered by this Parts Catalog are as follows:
  - (1) Serial numbers of the 1963 PA-30 Models are 30-2 to 30-142 inclusive.
  - (2) Serial numbers of the 1964 PA-30 Models are 30-143 to 30-627 Inclusive.
  - (3) Serial numbers of the 1965 PA-30 Models are 30-628 to 30-852, 30-854 to 30-901 inclusive.
  - (4) Serial numbers of the PA-30 Model "B" are 30-853, 30-902 to 30-1716, 30-1718 to 30-1744 inclusive.
  - (5) Serial numbers of the PA-30 Model "C" are 30-1717, 30-1745 to 30-2000 inclusive.
  - (6) Serial numbers of the PA-39 Model are 39-1 to 39-155 inclusive.

# PIPER PARTS CATALOG

## STANDARD PAINT CHART

	MFG. NO.	PIPER PART NUMBER	
		QUART	GALLON
<b>EXTERIOR</b>			
<b>ACRYLIC LACQUER</b>			
Juneau White	L8973	4175 655	1175 655
Monterey Maroon (base coat)	8908	4175 758	1175 758
Monterey Maroon (top coat)	8904	4175 757	1175 757
Madrid Red (base coat)	8276	4175 131	1175 131
Madrid Red (top coat)	8910	4175 589	1175 589
Denver Brown (base coat)	8989	4175 297	1175 297
Denver Brown (top coat)	8977	4175 298	1175 298
Tampa Green (base coat)	8998	4175 208	1175 208
Tampa Green (top coat)	8997	4175 207	1175 207
Newport Blue (base coat)	8988	4175 756	1175 756
Newport Blue (top coat)	8991	4175 755	1175 755
Beaumont Blue	8993	4175 754	1175 754
Bahama Blue	8911	4175 442	1175 442
Lakeland Blue	8979	4175 753	1175 753
Orlando Green	8981	4175 206	1175 206
Mocha Tan	8985	4175 750	1175 750
Pontiac Red	8954	4175 590	1175 590
Dakota Black	8906	4175 375	1175 375
Polar Gray	8986	4175 204	1175 204
Reno Gold (base coat)	8976	4175 343	1175 343
Reno Gold (top coat)	8974	4175 342	1175 342
Nassau Turquoise	8978	4175 751	1175 751
Bimini Turquoise	8992	4175 752	1175 752
Ocala Orange (base coat)	8909	4175 503	1175 503
Ocala Orange (top coat)	8907	4175 502	1175 502
Dallas Yellow	8975	4175 702	1175 702
Lincoln Gray	8987	4175 205	1175 205
Avocado	8955	4175 209	1175 209
Las Vegas Gold (base coat)	8931	4175 327	1175 327
Las Vegas Gold (top coat)	8929	4175 328	1175 328
Thinner (fast drying) Titanine	8930	4179 138	1179 138
Thinner (slow drying) Titanine	8970	4179 134	1179 134

# TABLE OF CONTENTS

FIGURE NUMBER	FIGURE TITLE	GRID NUMBER
1	View of Complete Airplane .....	1A10
SECTION I WING GROUP		
2	Wing Installation .....	1A11
3	Flap and Aileron Assemblies .....	1A16
4	Wing Leading Edge .....	1A20
5	Wing Rear Spar Section .....	1B1
6	Wing Skin .....	1B5
SECTION II FUSELAGE GROUP		
7	Fuselage Forward Section .....	1B8
8	Complete Fuselage (PA-30 S/N 30-2 to 30-852, 30-854 to 30-901 incl.) .....	1B12
8A	Complete Fuselage (PA-30 S/N 30-853, 30-902 and up) (PA-39 S/N 39-1 and up) .....	1B15
9	Fuselage Top Section (PA-30 S/N 30-2 to 30-852, 30-854 to 30-901 incl.) .....	1B19
9A	Fuselage Top Section (PA-30 S/N 30-853, 30-902 and up) (PA-39 S/N 39-1 and up) .....	1B22
10	Fuselage Front Frame Assembly .....	1C2
11	Fuselage Rear Frame Assembly (PA-30 S/N 30-2 to 30-852, 30-854 to 30-901 incl.) .....	1C7
11A	Fuselage Rear Frame Ass'y. (PA-30 S/N 30-853, 30-902 and up) (PA-39 S/N 39-1 and up) .....	1C11
11B	Fuselage Firewall Assembly .....	1C16
12	Fuselage - Aft Section .....	1C22
13	Floorboard Installation .....	1D3
14	Instrument Panel Instl. (PA-30 S/N 30-2 to 30-1716 incl. 30-1718 to 30-1744 incl.) .....	1D8
14A	Instrument Panel Instl. (PA-30 S/N 30-1717, 30-1745 and up) (PA-39 S/N 39-1 and up) .....	1D14
15	Cockpit Finishing Instl. (PA-30 S/N 30-2 to 30-852, 30-854 to 30-901 incl.) .....	1D21
15A	Cockpit Finishing Instl. (PA-30 S/N 30-853, 30-902 and up) (PA-39 S/N 39-1 and up) .....	1E2
15B	Window Curtain Installation .....	1E8
16	Enclosure Installation (PA-30 S/N 30-2 to 30-852, 30-854 to 30-901 incl.) .....	1E10
16A	Enclosure Installation (PA-30 S/N 30-853, 30-902 and up) (PA-39 S/N 39-1 and up) .....	1E13
17	Cabin Door .....	1E17
17A	Baggage Compartment Door Assembly .....	1E21
18	Seats Installation (PA-30 S/N 30-2 to 30-852, 30-854 to 30-901 incl.) .....	1F1
18A	Seats Installation (PA-30 S/N 30-853, 30-902 and up) (PA-39 S/N 39-1 and up) .....	1F7
18B	Vertically Adjustable Seats Instl. (PA-30 S/N 30-1717, 30-1745 and up) (PA-39 S/N 39-1 and up) .....	1F14
19	Heater and Defroster System .....	1F17
20	Stewart-Warner Heater Assembly (PA-30 only) .....	1F22
20A	Janitrol Heater Assembly .....	1G1
20B	Janitrol Heater Components .....	1G4
21	Ventilating System .....	1G7
22	Vacuum System Installation .....	1G11
23	Airspeed, Static, Oil Pressure and Manifold Pressure Lines .....	1G14
23A	Oxygen System Installation (PA-30 S/N 30-2 to 30-852, 30-854 to 30-901 incl.) .....	1G18
23B	Oxygen System Instl. (PA-30 S/N 30-853, 30-902 to 30-1716, 30-1718 to 30-1744 incl.) .....	1G21
23C	Oxygen System Instl. (PA-30 S/N 30-1717, 30-1745 and up) (PA-39 S/N 39-1 and up) .....	1H1

# TABLE OF CONTENTS

FIGURE NUMBER	FIGURE TITLE	GRID NUMBER
<b>SECTION III CHASSIS GROUP</b>		
24	Nose Gear Installation .....	1H5
25	Main Landing Gear Installation .....	1H10
26	Landing Gear Strut Assemblies .....	1H15
27	Main Wheel and Brake Assembly .....	1H20
27A	Nose Wheel Assembly .....	1H23
28	Landing Gear Door Installation .....	1I2
29	Landing Gear Retraction System .....	1I4
30	Toe Brake Installation .....	1I7
30A	Dual Brake Installation .....	1I10
<b>SECTION IV TAIL SURFACES GROUP</b>		
31	Tail Surfaces Installation .....	1I13
32	Stabilator Assembly .....	1I17
33	Rudder Assembly .....	1I21
34	Fin Assembly .....	1I23
<b>SECTION V POWER PLANT GROUP</b>		
35	Power Plant and Baffle Installation .....	1J1
35A	Propeller Assembly .....	1J7
35B	Propeller Synchrophaser System Installation .....	1J11
36	Engine Nacelle Installation .....	1J13
37	Engine Controls Installation .....	1J19
<b>SECTION VI FUEL SYSTEM GROUP</b>		
38	Fuel System Installation .....	1K1
39	Fuel Cell Installation - Inboard .....	1K6
40	Fuel Cell Installation - Outboard .....	1K9
40A	Wing Tip Tank Installation .....	1K13
<b>SECTION VII ELECTRICAL SYSTEM GROUP</b>		
41	Electrical System - Forward .....	1K16
42	Electrical System - Aft .....	1L1
42A	Cockpit Electrical Instl. (PA-30 S/N 30-2 to 30-1716, 30-1718 to 30-1744 incl.) .....	1L4
42B	Cockpit Electrical Instl. (PA-30 S/N 30-1717, 30-1745 and up) (PA-39 S/N 39-1 and up) ..	1L6
42C	External Power Supply (PA-30 S/N 30-2 to 30-852, 30-854 to 30-901 incl.) .....	1L9
42D	External Power Supply (PA-30 S/N 30-853, 30-902 and up) (PA-39 S/N 39-1 and up) ..	1L11
42E	Anti-Collision Strobe Light Instl. (PA-39 only) .....	1L13



# TABLE OF CONTENTS

FIGURE NUMBER	FIGURE TITLE	GRID NUMBER
<b>SECTION VIII CONTROL SYSTEM GROUP</b>		
43	Control Wheel Installation .....	2A4
44	Rudder Pedal Installation .....	2A8
45	Control Surfaces Control Systems .....	2A11
46	Flap Control Mechanism Installation .....	2A15
47	Rudder Trim Mechanism Installation .....	2A19
48	Stabilator Trim Mechanism Installation .....	2A23
<b>SECTION IX ELECTRONICS GROUP</b>		
49	AutoControl II Installation (PA-30 only) .....	2B3
50	AutoControl III Installation .....	2B6
51	AltiMatic II Installation (PA-30 only) .....	2B8
52	AltiMatic III and AltiMatic III B Installations .....	2B13
52A	AltiMatic Pilot III B-1 Installation (PA-39 only) .....	2B18
53	Glide Sprocket Coupler Installation .....	2B21
54	Anti-Static Equipment Installation .....	2B23
54A	Piper Automatic Locator (ELT) Installation (Garrett Mfg. LTD) .....	2C1
54B	Piper Automatic Locator (ELT) Installation (Narco Avionics) .....	2C3
55	Piper PM-1 Marker Beacon Installation .....	2C5
56	Radio Junction Boxes (PA-30 S/N 30-2 to 30-1716, 30-1718 to 30-1744 incl.) .....	2C7
57	Radio Junction Boxes (PA-30 S/N 30-1717, 30-1745 and up) (PA-39 S/N 39-1 to 39-145 inclusive) .....	2C10
57A	Radio Junction Boxes (PA-39 S/N 39-146 and up) .....	2C12
	Radio Drawings .....	2C14
<b>SECTION X MISCELLANEOUS GROUP</b>		
	Optional Equipment Kits and Repair Kits .....	2C16
	Decals .....	2C21
	<b>NUMERICAL INDEX</b>	2D1

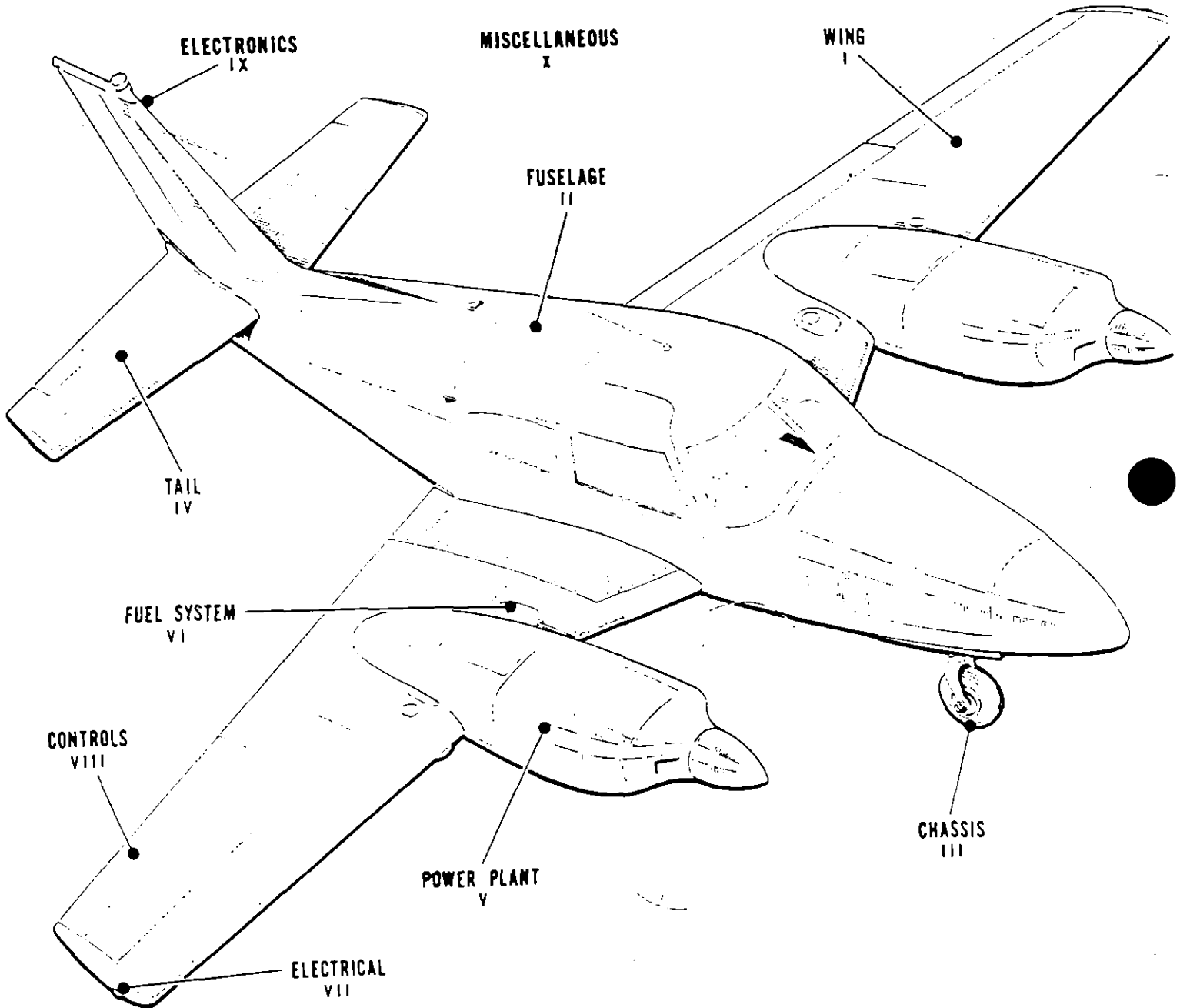

Figure 1. View of Complete Airplane

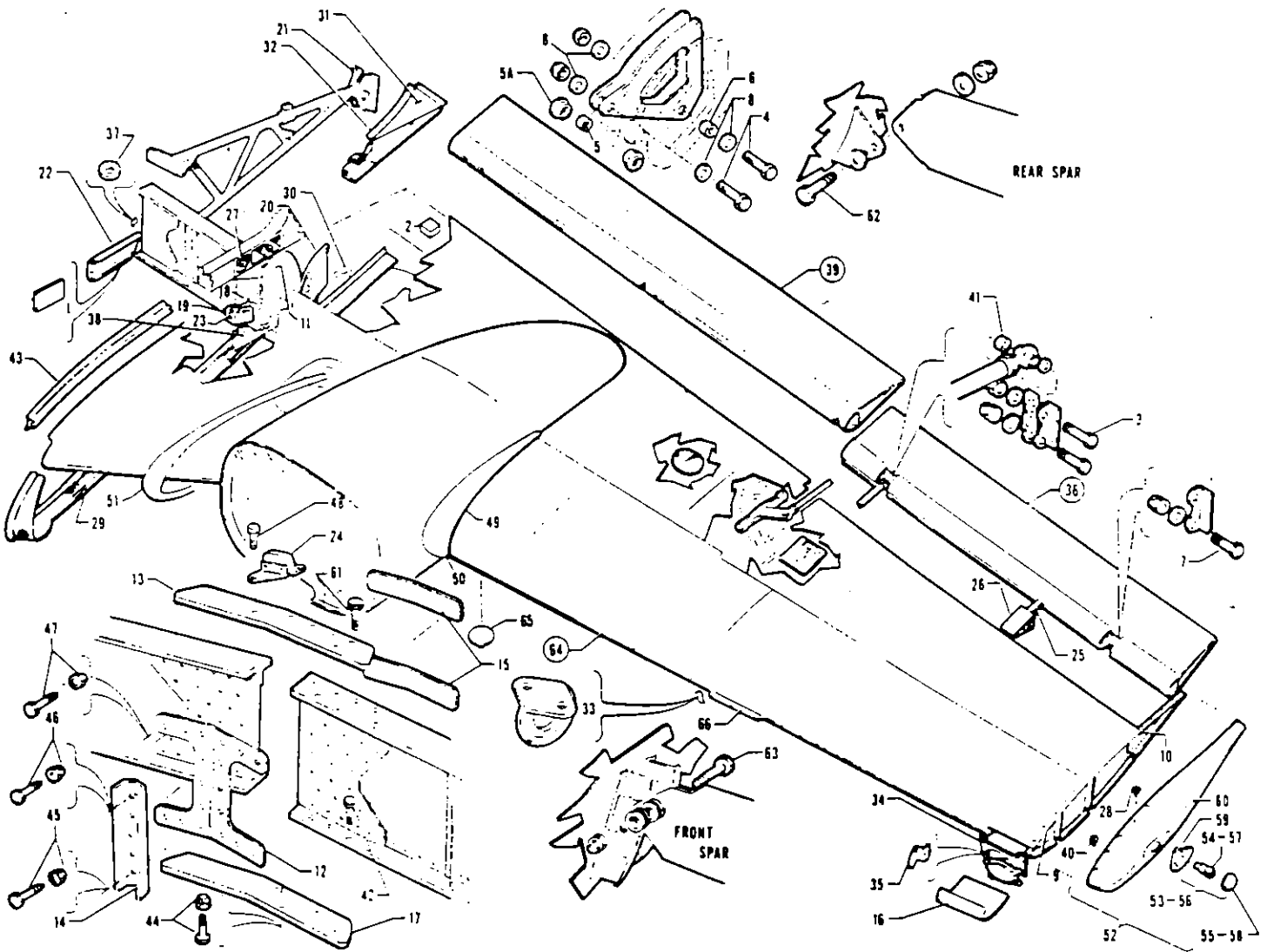

Figure 2. Wing Panel Installation

SECTION I  
Wing Group



WING PANEL INSTALLATION

Figure and Index Number	Part Number	Code	NOMENCLATURE	No. Req.	SERIAL NUMBERS AFFECTED
2-	24017 20958 24005		DRAWING - Wing Installation DRAWING - Wing Root Fairing Installation DRAWING - Nacelle Fairing Installation		
-1	11473-91		PLATE - Spar. seal	2	
-2	13945-42		BUMPER - Main wheel	2	
-3	401 312 407 585		BOLT - Inboard aileron hinge and control rod (AN4-12A) WASHER - Inboard aileron hinge and control rod	4	
	404 885		(AN960-416L) NUT - Inboard aileron hinge and control rod	4	
			(MS20365-428C)	4	
-4	401 270 407 564 404 835		BOLT - Flap hinge attachment (AN3-11A) WASHER - Flap hinge attachment (AN960-10) NUT - Flap hinge attachment (MS20364-1032C)	12 12 12	
-5	14976-73	Y	BUSHING - Flap hinge, outer (Steel)	12	30-2 to 30-1679 inclusive
-5a	26343-00	YZ	ROLLER - Flap hinge, outer (Nylon)	24	30-1680 and up, 39-1 and up
-6	14976-72		BUSHING - Flap hinge, inner	12	
-7	401 311 407 585 404 888		BOLT - Outboard aileron hinge (AN4-11A) WASHER - Outboard aileron hinge (AN960-416L) NUT - Outboard aileron hinge (MS20365-428C)	2 2 2	
-8	19513-37	Y	WASHER - Flap hinge	24	30-2 to 30-1679 inclusive
-9	20272-06 20272-07		RIB - Wing nose, Sta. 211, LH RIB - Wing nose, Sta. 211, RH	1 1	
-10	20274-08 20274-09		RIB - Wing, Sta. 211, LH RIB - Wing, Sta. 211, RH	1 1	
-11	21918-00 21918-01		PLATE ASSEMBLY - Fuselage rear seal, LH PLATE ASSEMBLY - Fuselage rear seal, RH	1 1	
-12	20311-00		PLATE - Main spar attachment	1	
-13	20313-00		PLATE - Upper spar attachment	1	
-14	20314-00		CHANNEL - Spar attachment	1	
-15	20315-00 20315-02		STRAP - Main spar attachment, upper STRAP - Main spar attachment, lower	1 1	
-16	20348-00 20348-01		WINDOW - Landing light WINDOW - Landing light	1 1	
-17	20433-00		PLATE - Lower spar attachment	1	
-18	401 188 407 586 404 890		BOLT - Main spar attachment, rear (AN5-10A) WASHER - Main spar attachment, rear (AN960-516L) NUT - Main spar attachment, rear (MS20365-524C)	1 1 1	
-19	20476-00 20476-01		FITTING - Main spar bottom attachment, LH FITTING - Main spar bottom attachment, RH	1 1	
-20	20489-06 20489-07		PLATE ASSEMBLY - Main gear wheel well splash, LH PLATE ASSEMBLY - Main gear wheel well splash, RH	1 1	
-21	20527-00 20527-01		ANGLE - Main spar center support attachment, LH ANGLE - Main spar center support attachment, RH	1 1	
-22	20535-00 20535-01		PLATE - Fuselage cover, LH PLATE - Fuselage cover, RH	1 1	
-23	401 186 407 566 404 889		BOLT - Main spar attachment, front (AN5-6A) WASHER - Main spar attachment, front (AN960-516) NUT - Main spar attachment, front (MS20365-524C)	2 2 2	
-24	20593-00	Y	SUPPORT ASSEMBLY - Rear seat	1	30-2 to 30-552 inclusive, 30-554 to 30-901 inclusive

Y - Used on PA-30 airplanes only.  
Z - Used on PA-39 airplanes only.

When ordering, always specify Part Number, Description and Serial Number of Aircraft

PIPER PARTS CATALOG

Figure and Index Number	Part Number	Code	NOMENCLATURE	No. Req.	SERIAL NUMBERS AFFECTED
2-25	20720-00		ARM - Aileron balance weight	2	
-26	20721-00		WEIGHT - Aileron balance	2	
-27	401 189		BOLT - Main spar attachment, top (AN5-11A)	2	
	407 566		WASHER - Main spar attachment, top (AN960-516L)	2	
	404 889		NUT - Main spar attachment, top (MS20365-524C)	2	
-28	419 806		SCREW - Wing tip attachment, center (MS21207C6-8)	30	
	494 071		WASHER - Wing tip attachment, center (A3236-012-1)	30	
-29	20983-00		FAIRING ASSEMBLY - Wing root, front, left	1	
	20983-01		FAIRING ASSEMBLY - Wing root, front, right	1	
-30	20984-00		FAIRING ASSEMBLY - Wing root, lower, left	1	
	20984-01		FAIRING ASSEMBLY - Wing root, lower, right	1	
-31	21267-00		FAIRING ASSEMBLY - Flap, left	1	
	21267-01		FAIRING ASSEMBLY - Flap, right	1	
-32	20666-02		* MOULDING	3'	
-33	18457-00		RING - Tie down	2	
-34	20345-00		BRACKET - Landing light	2	
-35	20347-02		CLAMP - Landing light moulding	4	
-36	20234-00	AY	AILERON ASSEMBLY - Left (with trim tab)	1	30-2 to 30-1613 inclusive
	20234-44	AYZ	AILERON ASSEMBLY - Left (with trim tab)	1	30-1614 and up, 39-1 and up
	20234-01	AY	AILERON ASSEMBLY - Right (less trim tab)	1	30-2 to 30-1223 inclusive
	20234-27	AY	AILERON ASSEMBLY - Right (with trim tab)	1	30-1224 to 30-1613 inclusive
	20234-43	AYZ	AILERON ASSEMBLY - Right (with trim tab)	1	30-1614 and up, 39-1 and up
-37	80122-99		SHIM - (.091)	2	
-38	21919-08		SEAL - Main spar, front, left	1	
	21919-09		SEAL - Main spar, front, right	1	
-39	22699-00	AY	FLAP ASSEMBLY - Left	1	30-2 and up
	22699-00	AZ	FLAP ASSEMBLY - Left	1	39-1 to 39-127 inclusive
	27247-02	AZ	FLAP ASSEMBLY - Left	1	39-128 and up
	22699-01	A	FLAP ASSEMBLY - Right	1	
-40	419 806		SCREW - Wing tip attachment, front (MS21207C6-8)	8	
	494 071		WASHER - Wing tip attachment, front (A3236-012-1)	8	
-41	80012-94		BUSHING - Aileron rod spacer	2	
-42	401 393		BOLT - Main spar attachment, bottom (AN6-12A)	14	
	407 567		WASHER - Main spar attachment, bottom (AN960-616)	14	
	404 890		NUT - Main spar attachment, bottom (MS20365-624C)	14	
-43	20666-02		MOULDING - Wing root top	2	
-44	401 396		BOLT - Main spar attachment, bottom (AN6-15A)	2	
	407 567		WASHER - Main spar attachment, bottom (AN960-616)	2	
	404 890		NUT - Main spar attachment, bottom (MS20365-624C)	2	
-45	410 047		SCREW - Main spar attachment, center (AN509-10R-18)	4	
	407 584		WASHER - Main spar attachment, center (AN960-10L)	4	
	404 887		NUT - Main spar attachment, center (MS20365-1032C)	4	
-46	400 440		BOLT - Main spar attachment, center (AN3-6A)	6	
	407 584		WASHER - Main spar attachment, center (AN960-10L)	6	
	404 887		NUT - Main spar attachment, center (MS20365-1032C)	6	
-47	401 189		BOLT - Main spar attachment, center (AN5-11A)	8	
	407 566		WASHER - Main spar attachment, center (AN960-516)	8	
	404 889		NUT - Main spar attachment, center (MS20365-524C)	8	
-48	401 394		BOLT - Main spar splice, top (AN6-13A)	1	
	407 567		WASHER - Main spar splice, top (AN960-616)	1	
	404 890		NUT - Main spar splice, top (MS20365-624C)	1	

A - See Figure 3 for component parts.  
 Y - Used on PA-30 airplanes only.  
 Z - Used on PA-39 airplanes only.

When ordering, always specify Part Number, Description and Serial Number of Aircraft

PIPER PARTS CATALOG

Figure and Index Number	Part Number	Code	NOMENCLATURE	No. Req.	SERIAL NUMBERS AFFECTED
2-49	13945-60		STRIP - Nacelle fairing	8	
-50	23990-00		FAIRING ASSEMBLY - Outboard, left wing	1	
	23990-01		FAIRING ASSEMBLY - Outboard, right wing	1	
-51	23991-00		FAIRING ASSEMBLY - Inboard, left wing	1	
	23991-01		FAIRING ASSEMBLY - Inboard, right wing	1	
-52	20447-04	C.Y	TIP ASSEMBLY - Wing, LH (with navigation light)	1	30-2 to 30-709 inclusive
	20447-05	C.Y	TIP ASSEMBLY - Wing, RH (with navigation light)	1	30-2 to 30-709 inclusive
	20447-08	E.Y.Z	TIP ASSEMBLY - Wing, LH (with navigation light)	1	30-710 and up, 39-1 and up
	20447-07	E.Y.Z	TIP ASSEMBLY - Wing, RH (with navigation light)	1	30-710 and up, 39-1 and up
-53	472 666	E	* LIGHT - Navigation, right wing, green	1	
-54	751 381	E	* * BULB - (#1512)	1	
-55	751 201	E	* * LENS - Green	1	
-56	472 665	E	* LIGHT - Navigation, left wing, red	1	
-57	751 381	E	* * BULB - (#1512)	1	
-58	751 202	E	* * LENS - Red	1	
-59	20587-02	E	* REFLECTOR - Navigation light	1	
-60	21552-00	C.Y	* TIP ASSEMBLY - Left wing	1	30-2 to 30-709 inclusive
	21552-01	C.Y	* TIP ASSEMBLY - Right wing	1	30-2 to 30-709 inclusive
	24870-00	E.Y.Z	* TIP ASSEMBLY - Left wing	1	30-710 and up, 39-1 and up
	24870-01	E.Y.Z	* TIP ASSEMBLY - Right wing	1	30-710 and up, 39-1 and up
-61	401 393		BOLT - Main spar splice, top (AN6-12A)	15	
	407 567		WASHER - Main spar splice, top (AN960-616)	15	
	404 890		NUT - Main spar splice, top (MS20365-624C)	15	
-62	402 350		BOLT - Rear spar attachment (AN176-10A)	2	
	81342-05		WASHER - Rear spar attachment	4	
	404 890		NUT - Rear spar attachment (MS20365-624C)	2	
-63	401 393		BOLT - Front spar attachment (AN6-12A)	2	
	407 567		WASHER - Front spar attachment (AN960-616)	2	
	404 890		NUT - Front spar attachment (MS20365-624C)	2	
-64	23560-00	A.B	PANEL ASSEMBLY - Wing, LH	1	
	23560-06	A.D	PANEL ASSEMBLY - Wing, LH	1	
	23560-01	A.B	PANEL ASSEMBLY - Wing, RH	1	
	23560-07	A.D	PANEL ASSEMBLY - Wing, RH	1	
			A - All items on Figures 4, 5, 6, 39 and 40 are component parts of this assembly, also items 28 to 57 inclusive on Figure 36.		
			B - Used on PA-30 with serial numbers 30-2 to 30-852 inclusive, 30-854 to 30-901 inclusive.		
			C - Navigation light must be grounded to wing structure when replacing metal tip with plastic tip.		
			D - Used on PA-30 with serial numbers 30-853, 30-902 and up, and PA-39 with serial numbers 39-1 and up		
			E - See Figure 42E if anti-collision wing tip strobe lights are installed.		
			Y - Used on PA-30 airplanes only.		
			Z - Used on PA-39 airplanes only.		

When ordering, always specify Part Number, Description and Serial Number of Aircraft



Figure and Index Number	Part Number	Code	NOMENCLATURE	No. Req.	SERIAL NUMBERS AFFECTED
2-65 -60	25597-00 44275-02 44275-04 44275-02 44275-02 44275-04		PAD - Jack STREP - Flow, left wing STREP - Flow, left wing STREP - Flow, right wing STREP - Flow, right wing, inboard STREP - Flow, right wing, outboard	1 1 1 1 1 1	
<p>A - Used on PA-30 airplanes with counter-rotating right engine.                      B - Used on PA-30 airplanes if Airflow Modification Kit T60 409 has been installed per Service Letter 558.                      Z - Used on PA-39 airplanes only.</p>					

When ordering, always specify Part Number, Description and Serial Number of Aircraft

# PIPER PARTS CATALOG

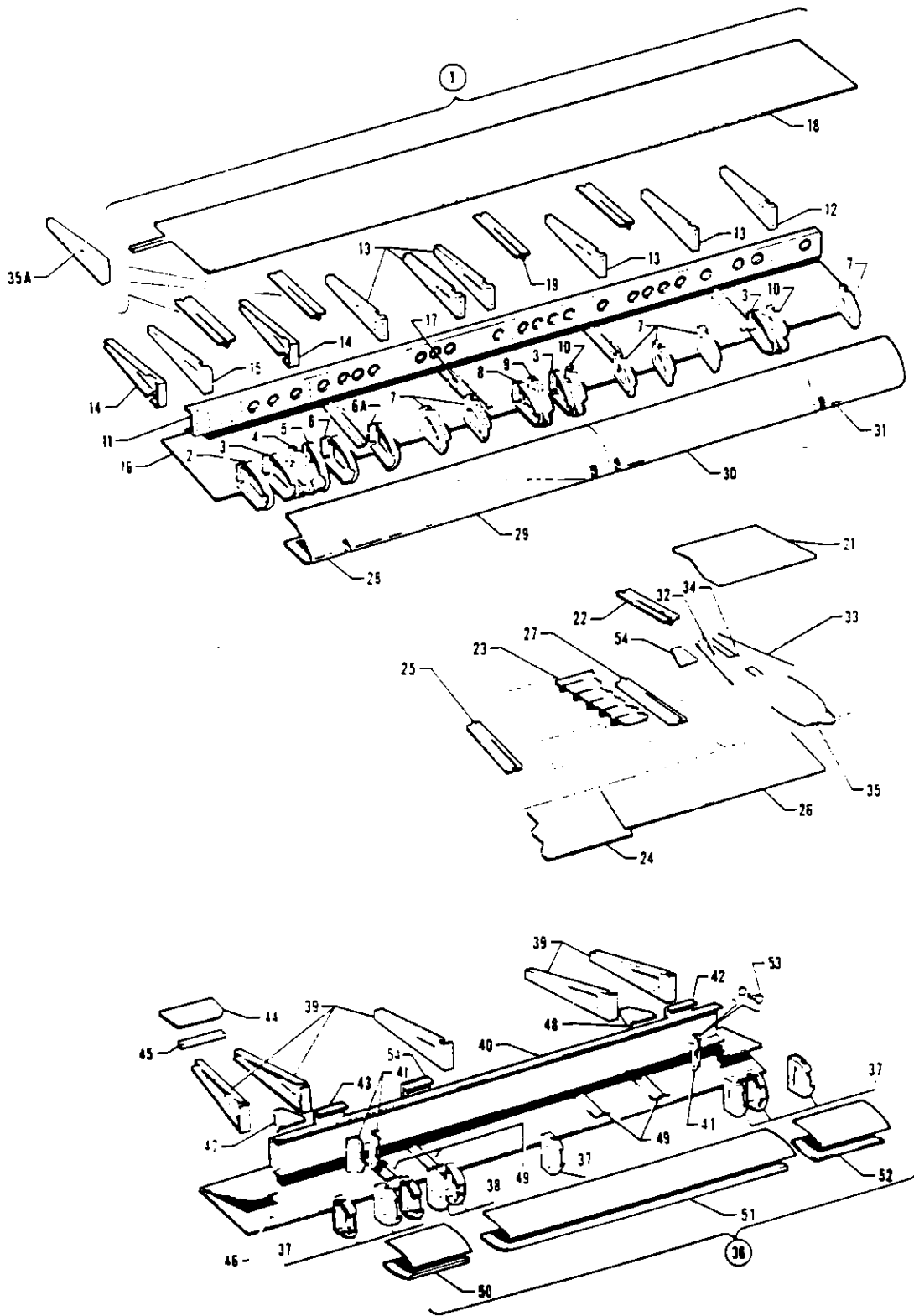

Figure 3. Flap and Aileron Assemblies





Figure and Index Number	Port Number	Code	NOMENCLATURE	No. Req	SERIAL NUMBERS AFFECTED
3-1	22699-00	Y	FLAP ASSEMBLY - Left	1	30-2 and up
	22699-00	Z	FLAP ASSEMBLY - Left	1	39-1 to 39-127 inclusive
	27247-02	Z	FLAP ASSEMBLY - Left	1	39-128 and up
	22699-01		FLAP ASSEMBLY - Right	1	
-2	22654-00		RIB - Flap nose, inboard, left	1	
	22654-01		RIB - Flap nose, inboard, right	1	
-3	22705-02		RIB ASSEMBLY - Flap, nose, left	3	
	22705-03		RIB ASSEMBLY - Flap, nose, right	3	
-4	22705-05		RIB ASSEMBLY - Flap, nose, left	1	
	22659-02		RIB ASSEMBLY - Flap, nose, right	1	
-5	22659-04		RIB ASSEMBLY - Flap, nose, left	1	
	22659-05		RIB ASSEMBLY - Flap, nose, right	1	
-6	22659-07		RIB ASSEMBLY - Flap, nose	1	
-6a	22659-06		RIB ASSEMBLY - Flap, nose, left	1	
	22659-07		RIB ASSEMBLY - Flap, nose, right	1	
-7	22659-07		RIB ASSEMBLY - Flap, nose, left	6	
	22659-06		RIB ASSEMBLY - Flap, nose, right	6	
-8	22704-00		RIB ASSEMBLY - Flap, nose, left	1	
	22704-01		RIB ASSEMBLY - Flap, nose, right	1	
-9	22704-01		RIB ASSEMBLY - Flap, nose, left	1	
	22704-00		RIB ASSEMBLY - Flap, nose, right	1	
-10	22705-03		RIB ASSEMBLY - Flap, nose, left	2	
	22705-02		RIB ASSEMBLY - Flap, nose, right	2	
-11	22683-00		SPAR - Flap	1	
-12	22669-00		RIB - Flap	1	
-13	22668-02		RIB - Flap	5	
-14	22667-00		RIB - Flap	2	
-15	22668-03		RIB - Flap, left	1	
-16	27247-07		SKIN ASSEMBLY - Flap, bottom, left	1	
-17	22714-00		STIFFENER - Bottom, left	4	
	22714-00		STIFFENER - Bottom, left outboard	2	
-18	27247-06		SKIN ASSEMBLY - Flap, top, left	1	
-19	22714-00		STIFFENER - Top, left	4	
	22714-00		STIFFENER - Top, left, outboard	2	
-20	20304-30		STRIP - Edge stiffener	1	
-21	22699-02		SKIN ASSEMBLY - Flap, top, right	1	
-22	22714-00		STIFFENER - Top, right	3	
-23	22699-03		PLATE - Reinforcement, right	1	
-24	22699-17		SKIN ASSEMBLY - Flap, bottom outboard, right	1	
-25	22714-00		STIFFENER - Bottom outboard, right	3	
-26	22699-19		SKIN ASSEMBLY - Flap, bottom inboard, right	1	
-27	22726-00		STIFFENER - Bottom inboard, right	1	
-28	22699-14		SKIN - Inboard	1	
-29	22699-12		SKIN - Center, inboard, left	1	
	22699-13		SKIN - Center, inboard, right	1	
-30	22699-10		SKIN - Center, outboard, left	1	
	22699-11		SKIN - Center, outboard, right	1	
-31	22699-08		SKIN - Outboard, left	1	
	22699-09		SKIN - Outboard, right	1	

Y - Used on PA-30 airplanes only.

Z - Used on PA-39 airplanes only.

When ordering, always specify Part Number, Description and Serial Number of Aircraft

# PIPER PARTS CATALOG

Figure and Index Number	Part Number	Code	NOMENCLATURE	No. Req.	SERIAL NUMBERS AFFECTED
3-32	22668-07		* RIB ASSEMBLY - Right	1	
-33	22668-06		* RIB ASSEMBLY - Right	1	
-34	23196-00		* BRACKET ASSEMBLY - Right	1	
-35	22699-29		* RIB ASSEMBLY - Right	1	
-35a	22668-02		* RIB - Flap	2	
-36	20234-00	Y	AILERON ASSEMBLY - Left (with trim tab)	1	30-2 to 30-1613 inclusive
	20234-44	YZ	AILERON ASSEMBLY - Left (with trim tab)	1	30-1614 and up, 39-1 and up
	20234-01	Y	AILERON ASSEMBLY - Right (less trim tab)	1	30-2 to 30-1223 inclusive
	20234-27	Y	AILERON ASSEMBLY - Right (with trim tab)	1	30-1224 to 30-1613 inclusive
	20234-43	YZ	AILERON ASSEMBLY - Right (with trim tab)	1	30-1614 and up, 39-1 and up
-37	20234-17		* RIB - Aileron, nose	7	
-38	20234-42		* BULKHEAD ASSEMBLY - Aileron, nose	2	
-39	20234-16		* RIB - Aileron	5	
-40	20213-00		* SPAR - Aileron	1	
-41	20211-00		* BRACKET - Aileron inboard hinge	2	
	760 914		* BRACKET ASSEMBLY - Aileron outboard hinge	1	
-42	20234-40		* PLATE ASSEMBLY - Aileron reinforcement	1	
-43	20234-15		* PLATE ASSEMBLY - Aileron reinforcement	1	
-44	21265-00		* TAB - Aileron trim	1	
-45	21270-00		* STRIP - Aileron reinforcement	1	
-46	20234-19		* SKIN ASSEMBLY - Aileron	1	
-47	20234-04		* * GUSSET - Left aileron, top, inboard and right aileron, bottom, inboard	1	
	20234-05		* * GUSSET - Left aileron, bottom, inboard and right aileron, top, inboard	1	
-48	20234-02		* * GUSSET - Left aileron, top, outboard and right aileron, bottom, outboard	1	
	20234-03		* * GUSSET - Left aileron, bottom, outboard and right aileron, top, outboard	1	
-49	20234-18		* * CHANNEL - Stiffener	8	
-50	20234-06		* SKIN - Top	1	
	20234-07		* SKIN - Bottom	1	
-51	20234-10		* SKIN - Top	1	
	20234-11		* SKIN - Bottom	1	
-52	20234-08		* SKIN - Top	1	
	20234-09		* SKIN - Bottom	1	
-53	400 438		* BOLT - (AN3-4A) Hinge attachment	6	
	407 584		* WASHER - (AN960-10L) Hinge attachment	6	
-54	20234-22		* PLATE ASSEMBLY - Aileron reinforcement	1	
-55	23087-00		PLATE - Flap access	1	

Y - Used on PA-30 airplanes only.  
Z - Used on PA-39 airplanes only.

When ordering, always specify Part Number, Description and Serial Number of Aircraft

**1 A19**

**INTENTIONALLY LEFT BLANK**

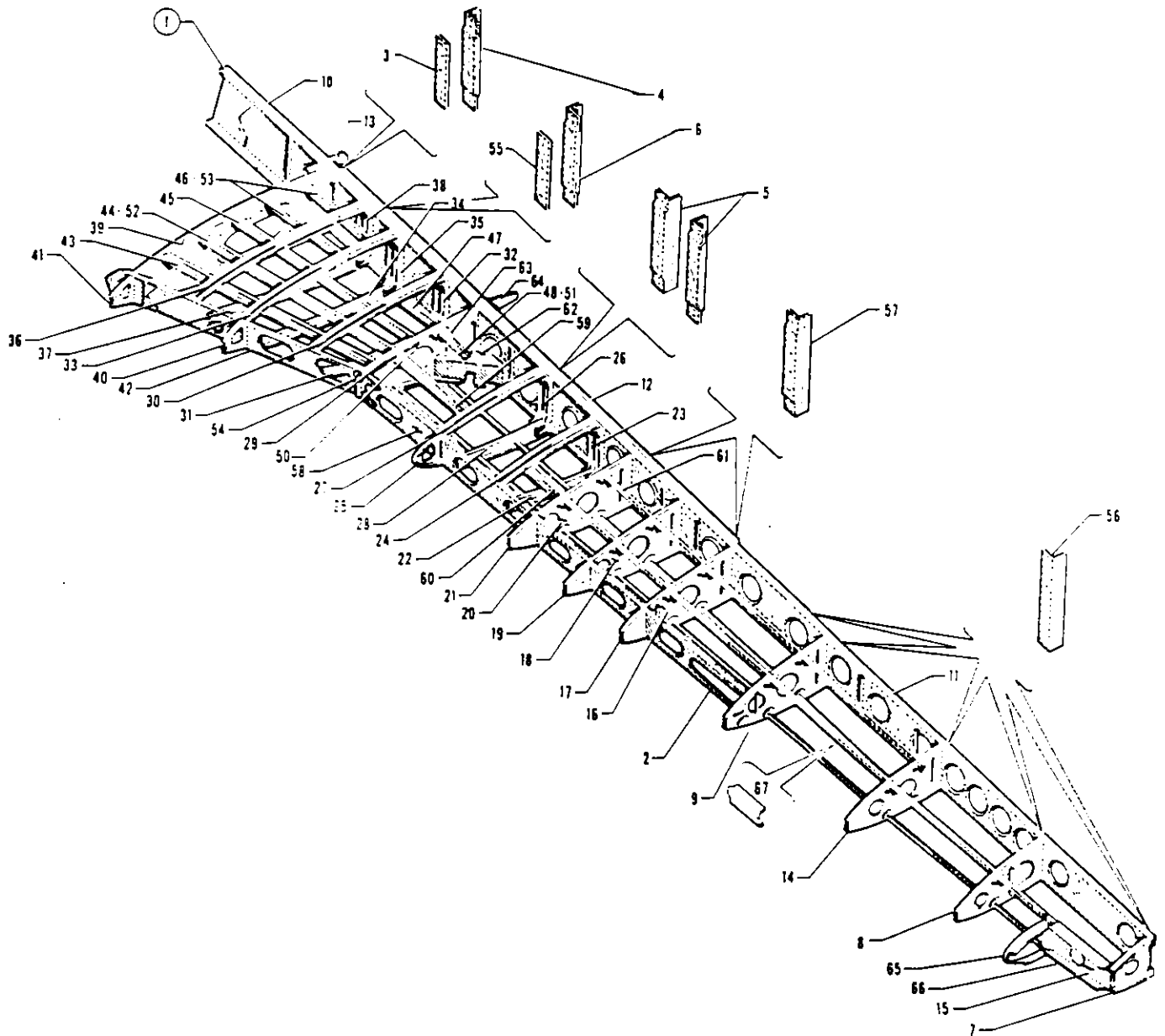

Figure 4. Wing - Leading Edge



Figure and Index Number	Part Number	Code	NOMENCLATURE	No. Req.	SERIAL NUMBERS AFFECTED
4-	23562		DRAWING - Wing Leading Edge Assembly		
-1	23562-00	AB	LEADING EDGE ASSEMBLY - Wing, left	1	
	23562-01	AB	LEADING EDGE ASSEMBLY - Wing, right	1	
-2	23508-00		TIP - Front spar, LH	1	
	23508-01		TIP - Front spar, RH	1	
-3	20386-02		SHIM - Sta. 25	2	
-4	20235-02		ANGLE - Sta. 25	1	
-5	20235-03		ANGLE - Sta. 78, inboard	1	
	20235-06		ANGLE - Sta. 78, outboard	1	
-6	20236-00		ANGLE - Sta. 32, left	1	
	20236-01		ANGLE - Sta. 32, right	1	
-7	20272-10		RIB - Wing, nose, Sta. 211, LH	1	
	20272-11		RIB - Wing, nose, Sta. 211, RH	1	
-8	20275-06		RIB - Wing, nose and center section, Sta. 197, LH	1	
	20275-07		RIB - Wing, nose and center section, Sta. 197, RH	1	
-9	20282-00		RIB - Wing, nose section, Sta. 143, LH	1	
	20282-03		RIB - Wing, nose section, Sta. 143, RH	1	
-10	20296-08		SPAR ASSEMBLY - Wing, main, left	1	
	20296-07		SPAR ASSEMBLY - Wing, main, right	1	
-11	20252-06		SPAR ASSEMBLY - Wing, main, outboard section, LH	1	
	20252-05		SPAR ASSEMBLY - Wing, main, outboard section, RH	1	
-12	23551-00		SPAR ASSEMBLY - Wing, main, inboard section, LH	1	
	23551-01		SPAR ASSEMBLY - Wing, main, inboard section, RH	1	
-13	20396-00		FITTING - Main spar attachment	2	
-14	20310-02		RIB - Wing, Sta. 169, LH	1	
	20310-03		RIB - Wing, Sta. 169, RH	1	
-15	20346-00		BRACKET - Landing light support	1	
-16	23488-06		RIB ASSEMBLY - Wing, Sta. 120, LH	1	
	23488-07		RIB ASSEMBLY - Wing, Sta. 120, RH	1	
-17	23488-02		RIB - Wing, nose, Sta. 120, LH	1	
	23488-03		RIB - Wing, nose, Sta. 120, RH	1	
-18	23530-06		RIB ASSEMBLY - Wing, Sta. 108, LH	1	
	23530-07		RIB ASSEMBLY - Wing, Sta. 108, RH	1	
-19	23530-02		RIB - Nose, wing, Sta. 108, LH	1	
	23530-03		RIB - Nose, wing, Sta. 108, RH	1	
-20	23523-06		RIB ASSEMBLY - Wing, Sta. 97, LH	1	
	23523-07		RIB ASSEMBLY - Wing, Sta. 97, RH	1	
-21	23523-02		RIB - Wing, nose, Sta. 97, LH	1	
	23523-03		RIB - Wing, nose, Sta. 97, RH	1	
-22	22158-10		RIB ASSEMBLY - Wing, bottom, Sta. 88, LH	1	
	22158-11		RIB ASSEMBLY - Wing, bottom, Sta. 88, RH	1	
-23	22158-02		RIB ASSEMBLY - Wing, bottom, Sta. 88, LH	1	
	22158-03		RIB ASSEMBLY - Wing, bottom, Sta. 88, RH	1	

A - All items on Figures 39 and 40 are component parts of this assembly.  
 B - See Figure 6 for Leading Edge Skins.

When ordering, always specify Part Number, Description and Serial Number of Aircraft

SECTION I  
Wing Group



WING - LEADING EDGE

Figure and Index Number	Part Number	Code	NOMENCLATURE	No. Req.	SERIAL NUMBERS AFFECTED
+24	22158-08	Y	RIB ASSEMBLY - Wing, top, Sta. 88, LH	1	
	22158-14	Z	RIB ASSEMBLY - Wing, top, Sta. 88, LH	1	
	22158-09	Y	RIB ASSEMBLY - Wing, top, Sta. 88, RH	1	
	22158-15	Z	RIB ASSEMBLY - Wing, top, Sta. 88, RH	1	
-25	23514-00		RIB - Wing, nose, Sta. 77, LH	1	
	23514-01		RIB - Wing, nose, Sta. 77, RH	1	
-26	22162-02		RIB - Wing, Sta. 77, LH	1	
	22162-03		RIB - Wing, Sta. 77, RH	1	
-27	22162-08	Y	RIB ASSEMBLY - Wing, top, Sta. 77, LH	1	
	22162-14	Z	RIB ASSEMBLY - Wing, top, Sta. 77, LH	1	
	22162-09	Y	RIB ASSEMBLY - Wing, top, Sta. 77, RH	1	
	22162-15	Z	RIB ASSEMBLY - Wing, top, Sta. 77, RH	1	
-28	22162-10		RIB - Wing, bottom, Sta. 77, LH	1	
	22162-11		RIB - Wing, bottom, Sta. 77, RH	1	
-29	23497-00		RIB ASSEMBLY - Wing, Sta. 62, LH	1	
	23497-01		RIB ASSEMBLY - Wing, Sta. 62, RH	1	
-30	20307-10	Y	RIB ASSEMBLY - Top, Sta. 52, LH	1	
	20307-14	Z	RIB ASSEMBLY - Top, Sta. 52, LH	1	
	20307-11	Y	RIB ASSEMBLY - Top, Sta. 52, RH	1	
	20307-15	Z	RIB ASSEMBLY - Top, Sta. 52, RH	1	
-31	20307-08		RIB ASSEMBLY - Bottom, Sta. 52, LH	1	
	20307-09		RIB ASSEMBLY - Bottom, Sta. 52, RH	1	
-32	20307-06		RIB ASSEMBLY - Sta. 52, LH	1	
	20307-07		RIB ASSEMBLY - Sta. 52, RH	1	
-33	20303-16	Y	RIB ASSEMBLY - Top, Sta. 41, LH	1	
	20303-22	Z	RIB ASSEMBLY - Top, Sta. 41, LH	1	
	20303-17	Y	RIB ASSEMBLY - Top, Sta. 41, RH	1	
	20303-23	Z	RIB ASSEMBLY - Top, Sta. 41, RH	1	
-34	20303-18		RIB ASSEMBLY - Bottom, Sta. 41, LH	1	
	20303-19		RIB ASSEMBLY - Bottom, Sta. 41, RH	1	
-35	20303-08		RIB ASSEMBLY - Sta. 41, LH	1	
	20303-09		RIB ASSEMBLY - Sta. 41, RH	1	
-36	20357-10		RIB ASSEMBLY - Top, Sta. 32, LH	1	
	20357-11		RIB ASSEMBLY - Top, Sta. 32, RH	1	
-37	20357-08		RIB ASSEMBLY - Bottom, Sta. 32, LH	1	
	20357-09		RIB ASSEMBLY - Bottom, Sta. 32, RH	1	
-38	20357-06		RIB ASSEMBLY - Sta. 32, LH	1	
	20357-07		RIB ASSEMBLY - Sta. 32, RH	1	
-39	23565-00		RIB ASSEMBLY - Wing butt, Sta. 25, LH	1	
	23565-01		RIB ASSEMBLY - Wing butt, Sta. 25, RH	1	
-40	23506-00		RIB - Nose, Sta. 41, LH	1	
	23506-01		RIB - Nose, Sta. 41, RH	1	
-41	23803-00		RIB ASSEMBLY - Wing butt, nose, Sta. 25, LH	1	
	23803-01		RIB ASSEMBLY - Wing butt, nose, Sta. 25, RH	1	
-42	23487-02		SPAR ASSEMBLY - Wing, front, LH	1	
	23487-03		SPAR ASSEMBLY - Wing, front, RH	1	

Y - Used on PA-30 airplanes only.  
Z - Used on PA-39 airplanes only.

When ordering, always specify Part Number, Description and Serial Number of Aircraft



Figure and Index Number	Part Number	Code	NOMENCLATURE	No. Req.	SERIAL NUMBERS AFFECTED
4-43	23564-00		STIFFENER - Wing leading edge, top, LH	1	
	23564-01		STIFFENER - Wing leading edge, top, RH	1	
-44	20273-16		STIFFENER - Wing leading edge, top, LH	1	
	20273-17		STIFFENER - Wing leading edge, top, RH	1	
-45	20273-06		STIFFENER - Wing leading edge, top, LH	1	
	20273-07		STIFFENER - Wing leading edge, top, RH	1	
-46	20273-10		STIFFENER - Wing leading edge, top, LH	2	
	20273-11		STIFFENER - Wing leading edge, top, RH	2	
-47	20273-20		STIFFENER - Wing leading edge, top, LH	1	
	20273-21		STIFFENER - Wing leading edge, top, RH	1	
-48	22157-04		ANGLE - Stiffener attachment, top, LH	1	
	22157-03		ANGLE - Stiffener attachment, top, RH	1	
-49	22157-02		ANGLE - Stiffener attachment, top, LH	1	
	22157-05		ANGLE - Stiffener attachment, top, RH	1	
-50	22157-05		ANGLE - Stiffener attachment, bottom, LH	1	
	22157-02		ANGLE - Stiffener attachment, bottom, RH	1	
-51	22157-03		ANGLE - Stiffener attachment, bottom, LH	1	
	22157-04		ANGLE - Stiffener attachment, bottom, RH	1	
-52	20273-17		STIFFENER - Wing leading edge, bottom, LH	1	
	20273-16		STIFFENER - Wing leading edge, bottom, RH	1	
-53	20273-18		STIFFENER - Wing leading edge, bottom, LH	1	
	20273-19		STIFFENER - Wing leading edge, bottom, RH	1	
-54	23534-00		ANGLE - Nacelle attachment	1	
	23534-01		ANGLE - Nacelle attachment	1	
-55	20386-03		SHM - Sta. 32	2	
-56	20237-02		ANGLE - Sta. 135	1	
	20237-03		ANGLE - Sta. 143	1	
	20237-04		ANGLE - Sta. 197	1	
	20237-05		ANGLE - Sta. 211	1	
	20237-06		ANGLE - Sta. 169	1	
-57	20235-04		ANGLE - Sta. 97	1	
	20235-05		ANGLE - Sta. 120	1	
-58	23519-00		SPAR - Wing front, center section, LH	1	
	23519-01		SPAR - Wing front, center section, RH	1	
-59	22178-02		STIFFENER - Wing leading edge, LH	1	
	22178-03		STIFFENER - Wing leading edge, RH	1	
-60	22178-04		STIFFENER - Wing leading edge, LH	1	
	22178-05		STIFFENER - Wing leading edge, RH	1	
-61	22178-06		STIFFENER - Wing leading edge, LH	2	
	22178-07		STIFFENER - Wing leading edge, RH	2	
-62	22268-00		LINER ASSEMBLY - Fuel cell corner, LH	1	
	22268-01		LINER ASSEMBLY - Fuel cell corner, RH	1	
-63	22302-00		STRINGER - Fuel cell, liner support, LH	1	
	22302-01		STRINGER - Fuel cell, liner support, RH	1	
-64	22649-00		ANGLE - Support plate attachment	1	
-65	20358-00		STRIP - Landing light window mounting, LH	1	
	20358-01		STRIP - Landing light window mounting, RH	1	
-66	20359-00		STRIP - Landing light window mounting	2	
-67	751 228		ANGLE - Stringer (6 ft. section)	1	

When ordering, always specify Part Number, Description and Serial Number of Aircraft

**1 A24**  
INTENTIONALLY LEFT BLANK



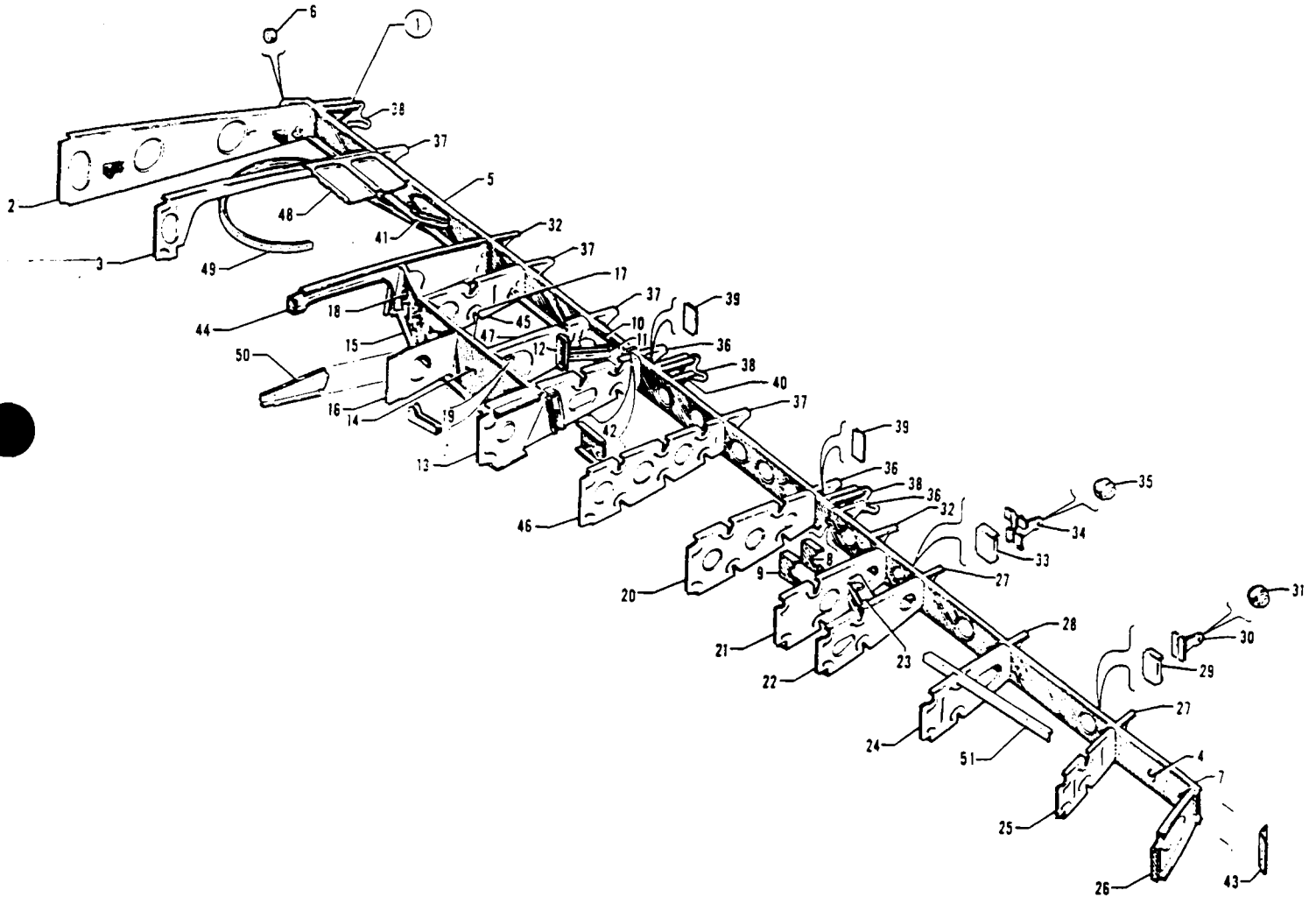

Figure 5. Wing - Rear Spar Section



Figure and Index Number	Part Number	Code	NOMENCLATURE	No. Req	SERIAL NUMBERS AFFECTED
5-	23480		DRAWING - Rear Spar Assembly		
-1	23480-04	A	TRAILING EDGE ASSEMBLY - Wing, left	1	
	23480-08	B	TRAILING EDGE ASSEMBLY - Wing, left	1	
	23480-05	A	TRAILING EDGE ASSEMBLY - Wing, right	1	
	23480-09	B	TRAILING EDGE ASSEMBLY - Wing, right	1	
-2	23505-00	A	RIB ASSEMBLY - Wing, Sta. 25, left	1	
	25410-00	B	RIB ASSEMBLY - Wing, Sta. 25, left	1	
	23505-01	A	RIB ASSEMBLY - Wing, Sta. 25, right	1	
	25410-01	B	RIB ASSEMBLY - Wing, Sta. 25, right	1	
-3	22803-00	Y	RIB ASSEMBLY - Wing, Sta. 33 1/16, left	1	30-2 to 30-597 inclusive
	22803-01	Y	RIB ASSEMBLY - Wing, Sta. 33 1/16, right	1	30-2 to 30-597 inclusive
	22803-04	YZ	RIB ASSEMBLY - Wing, Sta. 33 1/16, left	1	30-598 and up. 39-1 and up
	22803-05	YZ	RIB ASSEMBLY - Wing, Sta. 33 1/16, right	1	30-598 and up. 39-1 and up
-4	23479-00		SPAR ASSEMBLY - Wing rear (complete), left	1	
	23479-01		SPAR ASSEMBLY - Wing rear (complete), right	1	
-5	23476-00		SPAR ASSEMBLY - Wing rear, inboard, left	1	
	23476-01		SPAR ASSEMBLY - Wing rear, inboard, right	1	
-6	80022-92		BUSHING	1	
-7	20266-02		SPAR ASSEMBLY - Wing rear, outboard, left	1	
	20266-03		SPAR ASSEMBLY - Wing rear, outboard, right	1	
-8	23479-04		PLATE - Splice, left	1	
	23479-05		PLATE - Splice, right	1	
-9	23479-02		SHDM - Splice plate, left	1	
	23479-03		SHDM - Splice plate, right	1	
-10	22789-00		BRACKET ASSEMBLY - Flap bellcrank, Sta. 68, left	1	
	22789-01		BRACKET ASSEMBLY - Flap bellcrank, Sta. 68, right	1	
-11	22789-04		BRACKET ASSEMBLY - Flap bellcrank, Sta. 68, left	1	
	22789-05		BRACKET ASSEMBLY - Flap bellcrank, Sta. 68, right	1	
-12	22801-00		PLATE - Support, flap bellcrank, Sta. 68, left	1	
	22801-01		PLATE - Support, flap bellcrank, Sta. 68, right	1	
-13	23465-00		RIB - Wing, center, Sta. 78, left	1	
	23465-01		RIB - Wing, center, Sta. 78, right	1	
-14	23480-02		BULKHEAD ASSEMBLY - Landing gear rear support, left	1	
	23480-03		BULKHEAD ASSEMBLY - Landing gear rear support, right	1	
-15	20324-02		BULKHEAD - Landing gear rear support, left	1	
	20324-03		BULKHEAD - Landing gear rear support, right	1	
-16	22566-00		PLATE - Landing gear support, wing, Sta. 62 7/8, left	1	
	22566-01		PLATE - Landing gear support, wing, Sta. 62 7/8, right	1	
-17	20340-00		REINFORCEMENT - Landing gear support bulkhead, left	1	
	20340-01		REINFORCEMENT - Landing gear support bulkhead, right	1	
		A	- Used on PA-30 with serial numbers 30-2 to 30-852 inclusive, 30-854 to 30-901 inclusive.		
		B	- Used on PA-30 with serial numbers 30-853, 30-902 and up, and PA-39 with serial numbers 39-1 and up.		
		Y	- Used on PA-30 airplanes only.		
		Z	- Used on PA-39 airplanes only.		

When ordering, always specify Part Number, Description and Serial Number of Aircraft



Figure and Index Number	Part Number	Code	NOMENCLATURE	No. Req.	SERIAL NUMBERS AFFECTED
5-18	23456-00		DOUBLER - Landing gear support bulkhead, left	1	
	23456-01		DOUBLER - Landing gear support bulkhead, right	1	
-19	20658-02		BRACKET - Flap return spring attachment	1	
-20	20269-00		RIB - Wing, Sta. 120, left	1	
	20269-01		RIB - Wing, Sta. 120, right	1	
-21	20318-00		RIB - Main, Sta. 135 5/8, left	1	
	20318-01		RIB - Main, Sta. 135 5/8, right	1	
-22	20283-00		RIB - Main, Sta. 143, left	1	
	20283-01		RIB - Main, Sta. 143, right	1	
-23	20309-00		BRACKET ASSEMBLY - Aileron bellcrank, left	1	
	20309-01		BRACKET ASSEMBLY - Aileron bellcrank, right	1	
-24	20310-04		RIB - Wing, Sta. 169, left	1	
	20310-05		RIB - Wing, Sta. 169, right	1	
-25	20275-04		RIB - Wing, Sta. 197, left	1	
	20275-05		RIB - Wing, Sta. 197, right	1	
-26	20274-06		RIB ASSEMBLY - Wing, Sta. 211, left	1	
	20274-07		RIB ASSEMBLY - Wing, Sta. 211, right	1	
-27	20288-00		BULKHEAD - Rear spar, Sta. 143 and 197, left	2	
	20288-01		BULKHEAD - Rear spar, Sta. 143 and 197, right	2	
-28	20262-00		BULKHEAD - Rear spar, Sta. 169, left	1	
	20262-01		BULKHEAD - Rear spar, Sta. 169, right	1	
-29	20284-00		PLATE - Aileron hinge bracket reinforcement, outboard, left	1	
	20284-01		PLATE - Aileron hinge bracket reinforcement, outboard, right	1	
-30	20294-00		BRACKET ASSEMBLY - Aileron hinge, outboard	1	
-31	25704-00		BEARING - Aileron hinge	1	
-32	22733-02		BULKHEAD - Rear spar, Sta. 47 and 131.90, right	2	
	22733-03		BULKHEAD - Rear spar, Sta. 47 and 131.90, left	2	
-33	20242-00		PLATE - Aileron hinge bracket reinforcement, inboard, left	1	
	20242-01		PLATE - Aileron hinge bracket reinforcement, inboard, right	1	
-34	20293-00		BRACKET ASSEMBLY - Aileron hinge, inboard	1	
-35	25704-00		BEARING - Aileron hinge	1	
-36	22733-06		BULKHEAD - Rear spar, Sta. 78 and 120, left	3	
	22733-07		BULKHEAD - Rear spar, Sta. 78 and 120, right	3	
-37	22733-04		BULKHEAD - Rear spar, Sta. 33, 55, 68 and 97, left	4	
	22733-05		BULKHEAD - Rear spar, Sta. 33, 55, 68 and 97, right	4	
-38	23227-03		TRACK ASSEMBLY - Flap	3	
-39	22780-00		PLATE - Flap track spacer	2	
-40	22733-08		BULKHEAD - Rear spar, Sta. 78, right	1	
	22733-09		BULKHEAD - Rear spar, Sta. 78, left	1	
-41	22768-00		BRACKET - Flap cable pulley	2	
-42	22783-02		PLATE - Flap track reinforcing, left	1	
	22783-03		PLATE - Flap track reinforcing, right	1	
-43	20247-00		ANGLE ASSEMBLY - Rear spar rib attachment, Sta. 211	1	
-44	23475-06		RIB - Wing, Sta. 47, left	1	
	23475-07		RIB - Wing, Sta. 47, right	1	
-45	20351-08		RIB - Wing, Sta. 55, left	1	
	20351-09		RIB - Wing, Sta. 55, right	1	
-46	20263-04		RIB ASSEMBLY - Wing, Sta. 97, left	1	
	20263-05		RIB ASSEMBLY - Wing, Sta. 97, right	1	
-47	22787-00		RIB - Wing, Sta. 68, left	1	
	22787-01		RIB - Wing, Sta. 68, right	1	

When ordering, always specify Part Number, Description and Serial Number of Aircraft



Figure and Index Number	Part Number	Code	NOMENCLATURE	No. Req.	SERIAL NUMBERS AFFECTED
5-48	20267-02		REINFORCEMENT ASSEMBLY - Walkway, left	1	
	21290-02		REINFORCEMENT ASSEMBLY - Walkway, right	1	
-49	20360-14		ANGLE - Gear opening reinforcement, left	1	
	20360-15		ANGLE - Gear opening reinforcement, right	1	
-50	21072-00		BULKHEAD - Landing gear door attachment, left	1	
	21072-01		BULKHEAD - Landing gear door attachment, right	1	
-51	751 228		ANGLE - Stringer (6 ft. section)	1	

When ordering, always specify Part Number, Description and Serial Number of Aircraft

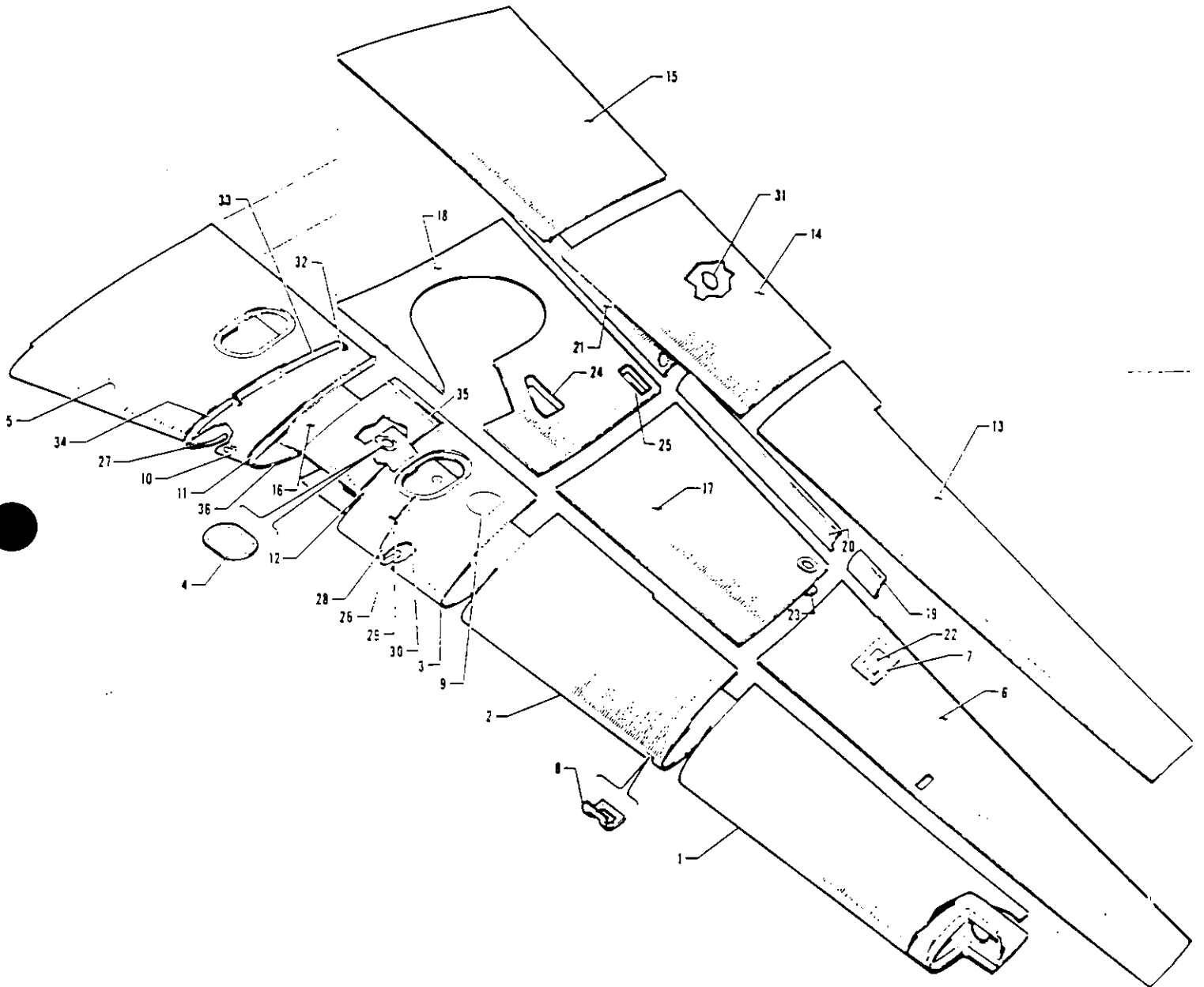

Figure 6. Wing Skin



Figure and Index Number	Part Number	Code	NOMENCLATURE	No. Req	SERIAL NUMBERS AFFECTED
6-	23560 23562 23540		DRAWING - Wing Panel Assembly DRAWING - Wing Leading Edge Assembly DRAWING - Engine Nacelle Installation		
-1	20377-45		SKIN ASSEMBLY - Wing panel leading edge, outboard, right	1	
	20377-46		SKIN ASSEMBLY - Wing panel leading edge, outboard, left	1	
-2	23562-10		SKIN ASSEMBLY - Wing panel leading edge, center, outboard, left	1	
	23562-11		SKIN ASSEMBLY - Wing panel leading edge, center, outboard, right	1	
-3	23562-06		SKIN ASSEMBLY - Wing panel leading edge, center, inboard, left	1	
	23562-07		SKIN ASSEMBLY - Wing panel leading edge, center, inboard, right	1	
-4	20370-00		PLATE - Access hole cover	1	
-5	23562-08		SKIN ASSEMBLY - Wing panel leading edge, inboard, left	1	
	23562-09		SKIN ASSEMBLY - Wing panel leading edge, inboard, right	1	
-6	20377-57		SKIN ASSEMBLY - Wing panel, outboard, bottom, right	1	
	20377-58		SKIN ASSEMBLY - Wing panel, outboard, bottom, left	1	
-7	17315-00		PLATE ASSEMBLY - Reinforcement	1	
-8	27065-00		PLATE ASSEMBLY - Reinforcement, lift detector	1	
-9	22982-02		PLATE ASSEMBLY - Fuel cell filler neck cover	1	
-10	23575-00		BRACKET - Wire clamp support	1	
-11	23520-00		ANGLE - Nacelle rib mounting, inboard, left	1	
	23520-01		ANGLE - Nacelle rib mounting, inboard, right	1	
-12	23521-00		ANGLE - Nacelle rib mounting, outboard, left	1	
	23521-01		ANGLE - Nacelle rib mounting, outboard, right	1	
-13	22700-14		SKIN ASSEMBLY - Wing panel, outboard, top, left	1	
	22700-15		SKIN ASSEMBLY - Wing panel, outboard, top, right	1	
-14	22700-12		SKIN ASSEMBLY - Wing panel, center, top, left	1	
	22700-13		SKIN ASSEMBLY - Wing panel, center, top, right	1	
-15	22700-02		SKIN - Wing panel, inboard, top, left	1	
	22700-03		SKIN - Wing panel, inboard, top, right	1	
-16	23054-04		SKIN ASSEMBLY - Wing panel leading edge, inboard, bottom, left	1	
	23054-05		SKIN ASSEMBLY - Wing panel leading edge, inboard, bottom, right	1	
-17	20377-55		SKIN ASSEMBLY - Wing panel, center, bottom, right	1	
	20377-56		SKIN ASSEMBLY - Wing panel, center, bottom, left	1	
-18	23560-03		SKIN - Wing panel, inboard, bottom, left	1	
	23560-02		SKIN - Wing panel, inboard, bottom, right	1	
-19	22751-06	Y	SPAR - False, wing panel, outboard, left	1	30-2 to 30-1503 inclusive
	25867-06	YZ	SPAR - False, wing panel, outboard, left	1	30-1504 and up, 39-1 and up
	22751-07	Y	SPAR - False, wing panel, outboard, right	1	30-2 to 30-1500 inclusive
	25867-07	YZ	SPAR - False, wing panel, outboard, right	1	30-1501 and up, 39-1 and up
-20	22751-02	Y	SPAR - False, wing panel, center, left	1	30-2 to 30-1503 inclusive
	25867-02	YZ	SPAR - False, wing panel, center, left	1	30-1504 and up, 39-1 and up
	22751-03	Y	SPAR - False, wing panel, center, right	1	30-2 to 30-1500 inclusive
	25867-03	YZ	SPAR - False, wing panel, center, right	1	30-1501 and up, 39-1 and up
-21	22751-04	Y	SPAR - False, wing panel, inboard, left	1	30-2 to 30-1503 inclusive
	25867-04	YZ	SPAR - False, wing panel, inboard, left	1	30-1504 and up, 39-1 and up
	22751-05	Y	SPAR - False, wing panel, inboard, right	1	30-2 to 30-1500 inclusive
	25867-05	YZ	SPAR - False, wing panel, inboard, right	1	30-1501 and up, 39-1 and up
			Y - Used on PA-30 airplanes only.		
			Z - Used on PA-39 airplanes only.		

When ordering, always specify Part Number, Description and Serial Number of Aircraft



Figure and Index Number	Part Number	Code	NOMENCLATURE	No. Req.	SERIAL NUMBERS AFFECTED
n-22	17310-00		PLATE - Aileron bellcrank access hole cover	1	
-23	20370-00		PLATE - Access hole cover	1	
-24	23474-00		PLATE - Wing access	1	
-25	22998-02		PLATE - Wing access, left	1	
	22998-03		PLATE - Wing access, right	1	
-26	23540-14		ANGLE - Nacelle mounting, bottom, outboard, LH	1	
	23540-15		ANGLE - Nacelle mounting, bottom, outboard, RH	1	
-27	23540-04		ANGLE - Nacelle mounting, bottom, inboard, LH	1	
	23540-05		ANGLE - Nacelle mounting, bottom, inboard, RH	1	
-28	23540-12		ANGLE - Nacelle mounting, top, outboard, LH	1	
	23540-13		ANGLE - Nacelle mounting, top, outboard, RH	1	
-29	23543-03		ANGLE - Nacelle mounting, top	2	
-30	23540-20		ANGLE - Nacelle mounting, top, outboard, LH	1	
	23540-21		ANGLE - Nacelle mounting, top, outboard, RH	1	
-31	24169-00		GUSSET - Wing reinforcement	1	
-32	23543-02		ANGLE - Nacelle mounting	2	
	23543-03		ANGLE - Nacelle mounting	2	
-33	23540-18		ANGLE - Nacelle mounting, outboard, LH	1	
	23540-19		ANGLE - Nacelle mounting, outboard, RH	1	
-34	23540-02		ANGLE - Nacelle mounting, outboard, LH	1	
	23540-03		ANGLE - Nacelle mounting, outboard, RH	1	
-35	23494-00		ANGLE - Nacelle bulkhead mounting	1	
-36	23526-00		ANGLE - Nacelle attachment bottom, inboard, LH	1	
	23526-01		ANGLE - Nacelle attachment bottom, inboard, RH	1	

When ordering, always specify Part Number, Description and Serial Number of Aircraft

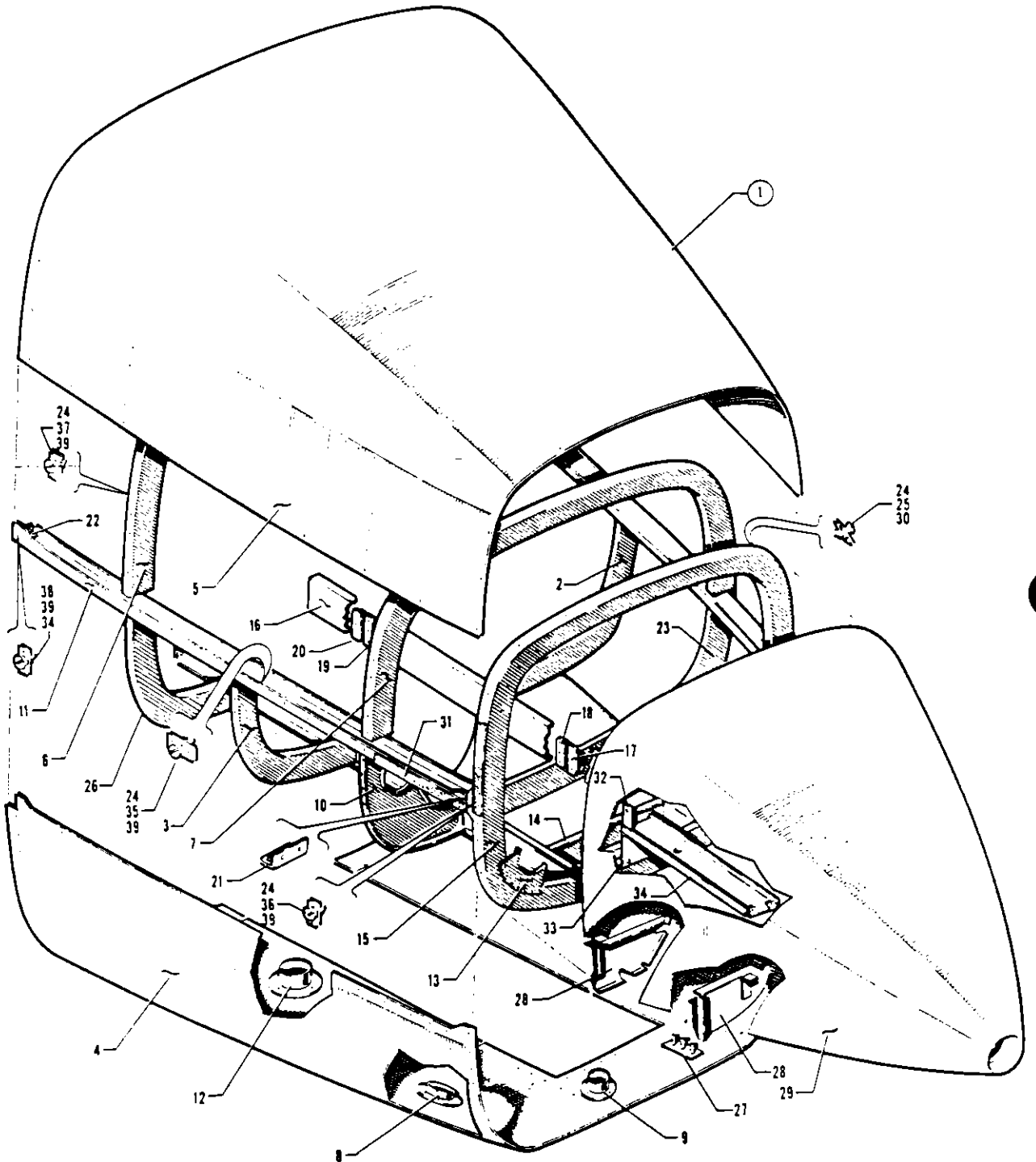

Figure 7. Fuselage Forward Section





Figure and Index Number	Part Number	Code	NOMENCLATURE	No. Req.	SERIAL NUMBERS AFFECTED
7-	23537		DRAWING - Forward Fuselage Section Assembly		
-1	23537-00	Y	SECTION ASSEMBLY - Forward fuselage	1	30-2 to 30-401 inclusive
	23537-37	A	SECTION ASSEMBLY - Forward fuselage	1	
	23537-39	B	SECTION ASSEMBLY - Forward fuselage	1	
-2	23537-02		BULKHEAD - Bottom, Sta. 30, LH	1	30-2 to 30-401 inclusive
-3	23537-03		BULKHEAD - Bottom, Sta. 30, RH	1	
-4	23537-25	Y	SKIN ASSEMBLY - Bottom	1	
	23537-33	A	SKIN ASSEMBLY - Bottom	1	30-2 to 30-401 inclusive
	23537-40	B	SKIN ASSEMBLY - Bottom	1	
-5	23537-08		SKIN ASSEMBLY - Top	1	
-6	23537-06		BULKHEAD - Top, Sta. 40	1	30-2 to 30-401 inclusive
-7	23537-07		BULKHEAD - Top, Sta. 20	1	
-8	17566-04		COVER ASSEMBLY - Heater exhaust shroud	1	
-9	19354-00		TUBE ASSEMBLY - Take-off	1	30-2 to 30-552 inclusive, 30-554 to 30-901 inclusive
-10	23693-00	Y	BRACKET - Heater, rear, right	1	
	25621-00	B	BRACKET - Heater, rear, right	1	
-11	23709-00		CHANNEL - Fuselage forward section, LH	1	30-2 to 30-401 inclusive
	23709-01		CHANNEL - Fuselage forward section, RH	1	
-12	23719-00	Y	TUBE ASSEMBLY - Heater overflow outlet	1	
-13	23741-00		BRACKET - Heater attachment, front	1	30-2 to 30-754 inclusive
-14	23755-00		BULKHEAD - Fuselage forward section, Sta. 17	1	
-15	23833-00		BULKHEAD - Fuselage, Sta. 11	1	
-16	23534-00	Y	CHANNEL ASSEMBLY - Forward section, lower LH	1	30-755 and up, 39-1 and up
	23534-04	YZ	CHANNEL ASSEMBLY - Forward section, lower LH	1	
	23534-01		CHANNEL ASSEMBLY - Forward section, lower RH	1	
-17	23874-00		BRACKET ASSEMBLY - Nose wheel fairing hinge, forward, front, LH	1	30-2 to 30-401 inclusive
	23874-01		BRACKET ASSEMBLY - Nose wheel fairing hinge, forward, front, RH	1	
-18	23875-00		BRACKET ASSEMBLY - Nose wheel fairing hinge, forward, rear, LH	1	
	23875-01		BRACKET ASSEMBLY - Nose wheel fairing hinge, forward, rear, RH	1	30-2 to 30-401 inclusive
-19	23877-00		BRACKET ASSEMBLY - Nose wheel fairing hinge, aft, front, LH	1	
	23877-01		BRACKET ASSEMBLY - Nose wheel fairing hinge, aft, front, RH	1	
-20	23878-00		BRACKET ASSEMBLY - Nose wheel fairing hinge, aft, rear, LH	1	30-2 to 30-401 inclusive
	23878-01		BRACKET ASSEMBLY - Nose wheel fairing hinge, aft, rear, RH	1	

A - Used on PA-30 with serial numbers 30-402 to 30-552 inclusive, 30-554 to 30-901 inclusive.  
 B - Used on PA-30 with serial numbers 30-553, 30-902 and up, and PA-39 with serial numbers 39-1 and up.  
 Y - Used on PA-30 airplanes only.  
 Z - Used on PA-39 airplanes only.

When ordering, always specify Part Number, Description and Serial Number of Aircraft

PIPER PARTS CATALOG

Figure and Index Number	Part Number	Code	NOMENCLATURE	No. Req.	SERIAL NUMBERS AFFECTED
7-21	23835-00		* CLIP - Fuselage forward section channel, front, RH	1	
	23835-01		* CLIP - Fuselage forward section channel, front, LH	1	
-22	23836-00		* CLIP - Fuselage forward section channel, rear	2	
-23	23837-15		* BULKHEAD - Sta. 20, left	1	
-24	484 322		* RECEPTACLE - (#82-35-302-15)	19	
-25	487 660		* STUD - (#2-F-140)	7	
-26	23837-38		* BULKHEAD - Bottom, Sta. 40, LH	1	
	23837-13		* BULKHEAD - Bottom, Sta. 40, RH	1	
-27	25490-00	A	* TUBE ASSEMBLY - Battery vent	1	
-28	25502-00	A	* BRACKET ASSEMBLY - Battery support, front	1	
	25514-00	A	* BRACKET ASSEMBLY - Battery support, rear	1	
-29	23755-00		* NOSE - Fuselage section assembly	1	
-30	484 482		* RETAINING RING - (PS10017-2-64)	7	
-31	180 806		* WEBBING - Anti-squeak (1/32 x 7/8)	13	
-32	24794-00	YZ	* ANGLE - Control cable support	1	30-422 and up, 39-1 and up
-33	24796-00	YZ	* PLATE - Marker beacon bracket support	1	30-422 and up, 39-1 and up
-34	24797-00	YZ	* BRACKET - Marker beacon mounting	1	30-422 and up, 39-1 and up
-35	487 661		STUD - (#2-F-180)	15	
-36	487 661		STUD - (#2-F-180)	2	
-37	487 670		STUD - (#2-F-240)	2	
-38	487 671		STUD - (#2-F-260)	2	
-39	484 482		RETAINING RING - (PS10077-2-64)	21	

A - Used on PA-30 with serial numbers 30-853, 30-902 and up, and PA-39 with serial numbers 39-1 and up.  
 Y - Used on PA-30 airplanes only.  
 Z - Used on PA-39 airplanes only.

When ordering, always specify Part Number, Description and Serial Number of Aircraft

**1 B11**

**INTENTIONALLY LEFT BLANK**

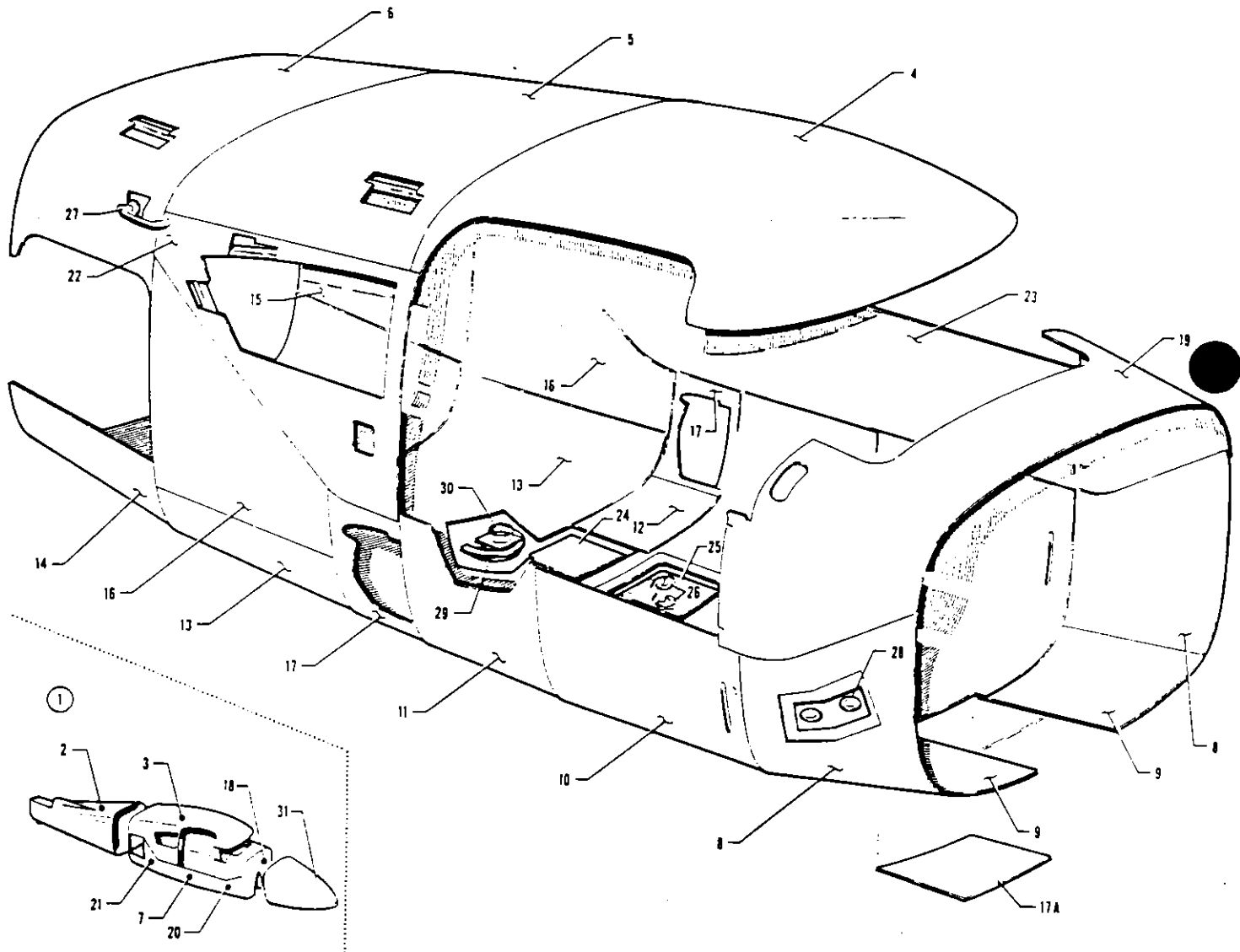

Figure 8. Complete Fuselage  
(PA-30 with Serial Nos. 30-2 to 30-852, 30-854 to 30-901 inclusive)



Figure and Index Number	Part Number	Code	NOMENCLATURE	No. Req.	SERIAL NUMBERS AFFECTED
8-	24076 23680		DRAWING - Fuselage Assembly (Complete) DRAWING - Fuselage Assembly		
-1	23680-00 23680-11	B	FUSELAGE ASSEMBLY FUSELAGE ASSEMBLY	1 1	30-2 to 30-589 inclusive
-2	24288-00	C	AFT SECTION ASSEMBLY	1	
-3	22566-00	D	FUSELAGE TOP SECTION ASSEMBLY	1	
-4	20600-09		SKIN - Fuselage top, forward	1	
-5	20600-87		SKIN ASSEMBLY - Fuselage top, center	1	
-6	22566-06		SKIN ASSEMBLY - Fuselage top, rear	1	
-7	23820-00 23820-17	B	FUSELAGE BOTTOM SECTION ASSEMBLY FUSELAGE BOTTOM SECTION ASSEMBLY	1 1	30-2 to 30-589 inclusive
-8	23820-04 23820-05		SKIN - Left side, front SKIN - Right side, front	1 1	
-9	23820-06 23820-07		SKIN - Left side, bottom, front SKIN - Right side, bottom, front	1 1	
-10	23820-14		SKIN ASSEMBLY - Bottom front, center	1	
-11	23056-02		SKIN - Bottom center	1	
-12	20600-16 20600-15		SKIN - Fuselage, Sta. 105 to Sta. 113, left SKIN - Fuselage, Sta. 105 to Sta. 113, right	1 1	
-13	23056-03		SKIN - Bottom center, rear	1	
-14	22607-05		SKIN ASSEMBLY - Bottom, rear	1	
-15	22607-03		SKIN ASSEMBLY - Left side, rear	1	
-16	22607-09 22607-23		SKIN ASSEMBLY - Side, center rear, left SKIN ASSEMBLY - Side, center rear, right	1 1	
-17	20615-04 23756-02		SKIN - Fuselage, Sta. 105 to Sta. 113, left SKIN - Fuselage, Sta. 105 to Sta. 113, right	1 1	
-17a	23820-16		SKIN - Bottom, front, center	1	
-18	23776-00	E	FIREWALL AND INSTRUMENT PANEL ASSEMBLY	1	
-19	23776-03		SKIN ASSEMBLY - Top front	1	
-20	23703-00	F	FRAME ASSEMBLY - Fuselage, front	1	
-21	22620-00 22620-21	G BG	FRAME ASSEMBLY - Fuselage, rear FRAME ASSEMBLY - Fuselage, rear	1 1	30-2 to 30-589 inclusive
-22	23680-02 23680-07		SKIN ASSEMBLY - Rear window, left SKIN ASSEMBLY - Rear window, right	1 1	
-23	23680-03		SKIN ASSEMBLY - Left side window, lower	1	
-24	20555-02		PLATE - Fuselage cover	1	
-25	22520-02		PLATE ASSEMBLY - Fuel strainer access	1	
-26	22090-00		PLATE - Vent	2	
-27	761 077		KIT - Cabin assist handle replacement	1	
-28	463 391		GROMMET - Air vent (AN231-4)	5	

A - Used on PA-30 with serial numbers 30-2 to 30-852 inclusive, 30-854 to 30-901 inclusive.  
 B - Used on PA-30 with serial numbers 30-590 to 30-852 inclusive, 30-854 to 30-901 inclusive.  
 C - See Figure 12 for component parts.  
 D - See Figure 9 for component parts.  
 E - See Figure 11B for component parts.  
 F - See Figure 10 for component parts.  
 G - See Figure 11 for component parts

When ordering, always specify Part Number, Description and Serial Number of Aircraft

COMPLETE FUSELAGE  
(See Code "A")



SECTION II  
Fuselage Group

Figure and Index Number	Part Number	Code	NOMENCLATURE	No Req	SERIAL NUMBERS AFFECTED
8-29	22117-00		SCOOP - Cabin air	1	
-30	22122-00		TAKE-OFF ASSEMBLY - Cabin air exhaust	1	
-31	23837-00	B	FUSELAGE FORWARD SECTION ASSEMBLY	1	30-2 to 30-401 inclusive
	23837-37	B	FUSELAGE FORWARD SECTION ASSEMBLY	1	30-402 to 30-852, 30-854 to 30-901

A - Used on PA-30 with serial numbers 30-2 to 30-852 inclusive, 30-854 to 30-901 inclusive.  
B - See Figure 7 for component parts.

When ordering, always specify Part Number, Description and Serial Number of Aircraft

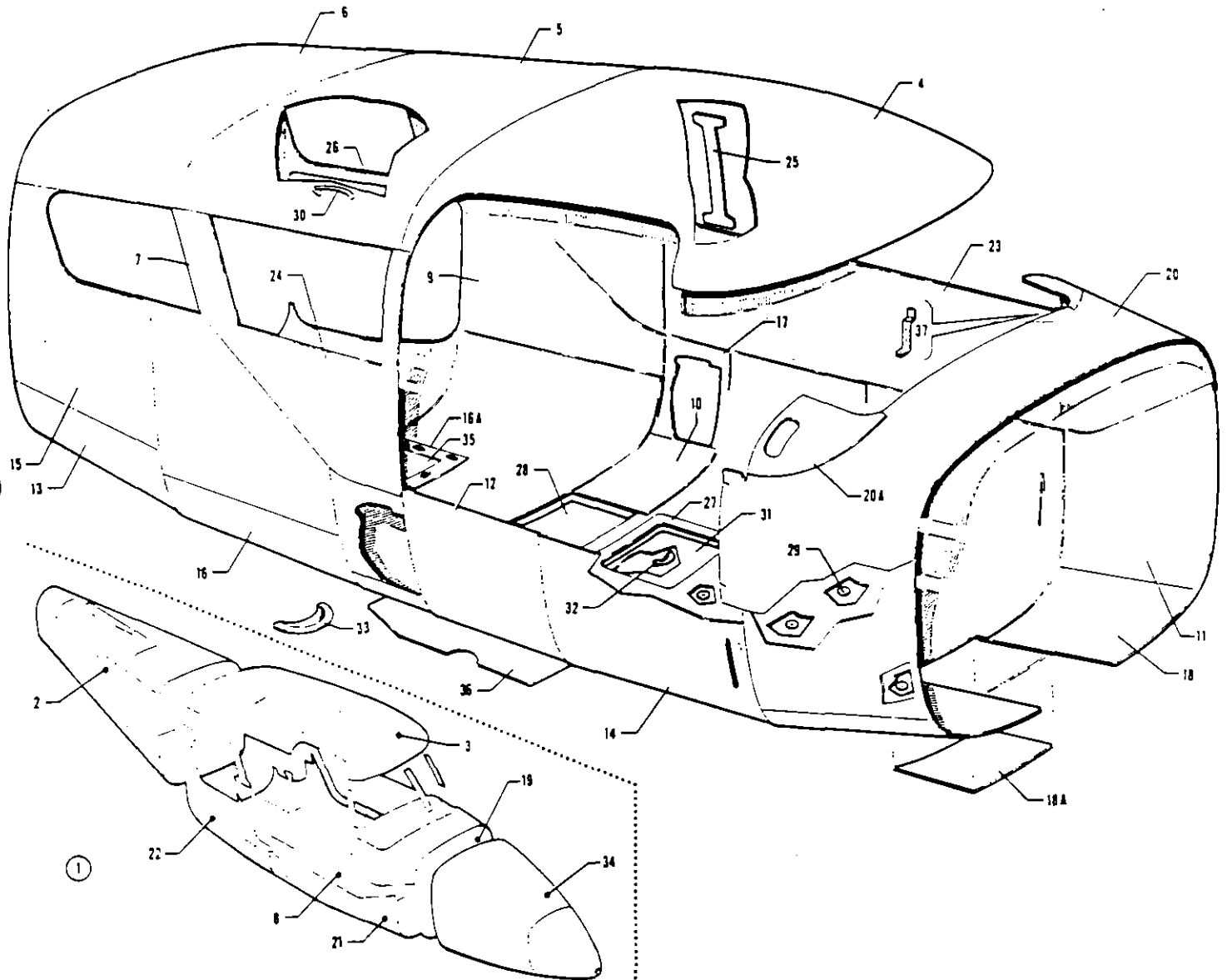

Figure 8A. Complete Fuselage  
 (PA-30 with Serial Nos. 30-853, 30-902 and up)  
 (PA-39 with Serial Nos. 39-1 and up)

SECTION II  
Fuselage Group



COMPLETE FUSELAGE  
(See Code "A")

Figure and Index Number	Part Number	Code	NOMENCLATURE	No. Req	SERIAL NUMBERS AFFECTED
8A-	25330	E	DRAWING - Fuselage Assembly (Complete)		
	26726	F	DRAWING - Fuselage Assembly (Complete)		
	25494	E	DRAWING - Fuselage Assembly		
	26450	F	DRAWING - Fuselage Assembly		
-1	25494-00	E	FUSELAGE ASSEMBLY	1	
	26450-00	G	FUSELAGE ASSEMBLY	1	
	26450-02	Z	FUSELAGE ASSEMBLY	1	39-84 to 39-145 inclusive
-2	26450-03	Z	FUSELAGE ASSEMBLY	1	39-146 and up
	25384-00	CG	AFT SECTION ASSEMBLY	1	
-3	25384-04	Z	AFT SECTION ASSEMBLY	1	39-84 and up
	25355-00	BY	FUSELAGE TOP SECTION ASSEMBLY	1	30-853, 30-902 to 30-1548
-4	25355-06	BYZ	FUSELAGE TOP SECTION ASSEMBLY	1	30-1549 and up, 39-1 and up
	20600-09		SKIN - Fuselage top, forward	1	
-5	25355-03		SKIN ASSEMBLY - Fuselage top, center	1	
-6	25355-06		SKIN ASSEMBLY - Fuselage top, rear	1	
-7	25461-02		SKIN - Fuselage top, side	2	
-8	25363-00	E	FUSELAGE BOTTOM SECTION ASSEMBLY	1	
	26361-00	G	FUSELAGE BOTTOM SECTION ASSEMBLY	1	
	26361-06	Z	FUSELAGE BOTTOM SECTION ASSEMBLY	1	39-84 to 39-145 inclusive
	26361-07	Z	FUSELAGE BOTTOM SECTION ASSEMBLY	1	39-146 and up
-9	25383-06		SKIN - Side, center, left	1	
	25383-07		SKIN - Side, center, right	1	
-10	20600-13		SKIN - Side, bottom center, rear, left	1	
	20600-16		SKIN - Side, bottom center, rear, right	1	
-11	23820-02		SKIN - Left side, front	1	
	23820-03		SKIN - Right side, front	1	
-12	23056-02		SKIN - Bottom, center	1	
-13	25383-02		SKIN - Bottom, rear	1	
-14	23820-13		SKIN - Bottom, front, center	1	
-15	25383-03		SKIN ASSEMBLY - Right side, rear	1	
-16	25382-02	Y	SKIN - Bottom, center, rear	1	30-853, 30-902 to 30-1552
	25382-07	D	SKIN ASSEMBLY - Bottom, center, rear	1	
	26360-03	F	SKIN - Bottom, center, rear, right	1	
	26360-02	F	SKIN - Bottom, center, rear, left	1	
-16a	17315-00	D	PLATE ASSEMBLY - Reinforcement	1	

A - Used on PA-30 with serial numbers 30-853, 30-902 and up, and PA-39 with serial numbers 39-1 and up.  
 B - See Figure 9A for component parts.  
 C - See Figure 12 for component parts.  
 D - Used on PA-30 with serial numbers 30-1553 to 30-1716 inclusive, 30-1718 to 30-1744 inclusive.  
 E - Used on PA-30 with serial numbers 30-853, 30-902 to 30-1716 inclusive, 30-1718 to 30-1744 inclusive  
 F - Used on PA-30 with serial numbers 30-1717, 30-1745 and up, and PA-39 with serial numbers 39-1 and up.  
 G - Used on PA-30 with serial numbers 30-1717, 30-1745 and up, and PA-39 with serial numbers 39-1 to 39-83 inclusive.  
 Y - Used on PA-30 airplanes only.  
 Z - Used on PA-39 airplanes only.

When ordering, always specify Part Number, Description and Serial Number of Aircraft





Figure and Index Number	Part Number	Code	NOMENCLATURE	No. Req.	SERIAL NUMBERS AFFECTED
8A-17	20615-04		SKIN - Fuselage, Sta. 105 to Sta. 113, left	1	
	23756-02		SKIN - Fuselage, Sta. 105 to Sta. 113, right	1	
-18	23820-06		SKIN - Left side, bottom, front	1	
	23820-07		SKIN - Right side, bottom, front	1	
-18a	23820-16		SKIN - Bottom, front, center	1	
-19	23776-04	HY	FIREWALL AND INSTRUMENT PANEL ASSEMBLY	1	31-853, 30-902 to 30-1700
	26339-00	HY	FIREWALL AND INSTRUMENT PANEL ASSEMBLY	1	30-1701 to 30-1716 inclusive, 30-1718 to 30-1744 inclusive
	26358-00	HJ	FIREWALL AND INSTRUMENT PANEL ASSEMBLY	1	
	26358-04	HZ	FIREWALL AND INSTRUMENT PANEL ASSEMBLY	1	39-84 to 39-145 inclusive
	26358-05	HZ	FIREWALL AND INSTRUMENT PANEL ASSEMBLY	1	39-146 and up
-20	23776-03	G	SKIN ASSEMBLY - Top front	1	
	26358-03	B	SKIN ASSEMBLY - Top front	1	
-20a	26498-00	B	SKIN - Top front, left	1	
	26498-01	B	SKIN - Top front, right	1	
-21	23703-00	DG	FRAME ASSEMBLY - Fuselage, front	1	
	23703-03	BD	FRAME ASSEMBLY - Fuselage, front	1	
-22	25333-00	EG	FRAME ASSEMBLY - Fuselage, rear	1	
	25333-17	BE	FRAME ASSEMBLY - Fuselage, rear	1	
-23	23680-08		SKIN - Front window, left	1	
-24	25461-04		SKIN - Center window, left	1	
	25461-05		SKIN - Center window, right	1	
-25	25461-03		SKIN - Top side, left	1	
-26	25461-06		SKIN - Left side, rear	1	
-27	22257-00		PLATE ASSEMBLY - Fuel strainer access reinforcement	1	
-28	20555-02	G	PLATE - Fuselage bottom cover	1	
-29	463 391		GROMMET - Air vent (AN231-4)	5	
-30	761 077		KIT - Cabin assist handle replacement	1	
-31	22520-02		PLATE ASSEMBLY - Fuel strainer access	1	
-32	22090-00		PLATE - Vent	2	
-33	22117-00		SCOOP - Cabin air	1	
-34	23827-39	C	FUSELAGE FORWARD SECTION ASSEMBLY	1	
-35	17316-00	F	PLATE - Access hole cover	1	
-36	25880-00	B	PLATE ASSEMBLY - Fuselage bottom cover	1	
-37	27280-00	Z	BRACKET - DME support	1	39-146 and up

A - Used on PA-30 with serial numbers 30-853, 30-902 and up, and PA-39 with serial numbers 39-1 and up.  
 B - Used on PA-30 with serial numbers 30-1717, 30-1745 and up, and PA-39 with serial numbers 39-1 and up.  
 C - See Figure 7 for component parts.  
 D - See Figure 10 for component parts.  
 E - See Figure 11A for component parts.  
 F - Used on PA-30 with serial numbers 30-1553 to 30-1716 inclusive, 30-1718 to 30-1744 inclusive.  
 G - Used on PA-30 with serial numbers 30-853, 30-902 to 30-1716 inclusive, 30-1718 to 30-1744 inclusive.  
 H - See Figure 11B for component parts.  
 J - Used on PA-30 with serial numbers 30-1717, 30-1745 and up, and PA-39 with serial numbers 39-1 to 39-83 inclusive.  
 Y - Used on PA-30 airplanes only.  
 Z - Used on PA-39 airplanes only.

When ordering, always specify Part Number, Description and Serial Number of Aircraft

**1 B18**

**INTENTIONALLY LEFT BLANK**

# PIPER PARTS CATALOG

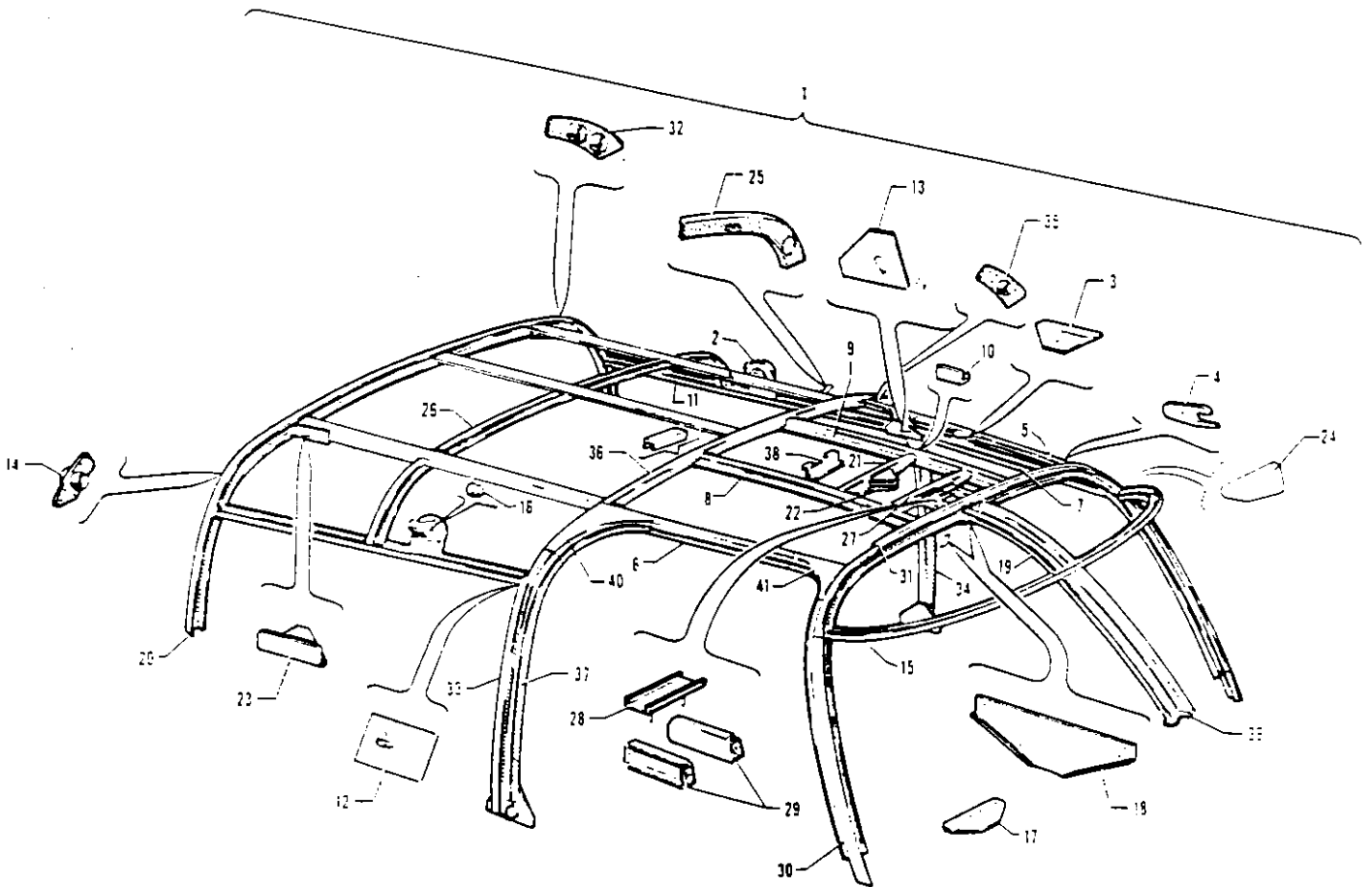

Figure 9 - Fuselage Top Section  
(PA-30 with Serial Nos. 30-2 to 30-852, 30-854 to 30-901 inclusive)

REVISED MAY 1960

1B19

PA-30

Island Enterprises



Figure and Index Number	Part Number	Code	NOMENCLATURE	No. Req.	SERIAL NUMBERS AFFECTED
9-	225cc		DRAWING - Fuselage Cabin Top		
-1	225cc-00		SECTION ASSEMBLY - Fuselage cabin top	1	
-2	21922-00		BOX ASSEMBLY - Ventilator, right rear	1	
	21922-01		BOX ASSEMBLY - Ventilator, left rear	1	
-3	20457-00		BRACKET - Wire clamp	1	
-4	20459-00		PLATE - Wire attachment	1	
-5	20600-24		STRINGER	1	
-6	20600-35		CHANNEL - Right	1	
-7	20600-89		CHANNEL - Left	1	
-8	20600-135		CHANNEL ASSEMBLY - Right	1	
-9	20600-136		CHANNEL ASSEMBLY - Left	1	
-10	21747-03		BRACKET - Trim strip support, rear	1	
	21747-04		BRACKET - Trim strip support, front	1	
-11	20507-00		CHANNEL - Fuselage center section top, rear, LH	1	
	20507-01		CHANNEL - Fuselage center section top, rear, RH	1	
-12	23254-00		GUSSET ASSEMBLY - Fuselage center section, RH	1	
-13	23255-00		GUSSET ASSEMBLY - Fuselage center section, LH	1	
-14	21923-00		CONNECTOR TUBE ASSEMBLY - Right	1	
-15	20561-03		CHANNEL - Top front	1	
-16	61402-39		BUSHING	2	
-17	20610-04		GUSSET	1	
-18	20610-05		GUSSET	1	
-19	20610-13		CHANNEL ASSEMBLY - Windshield	1	30-2 to 30-611 inclusive
	20610-03		CHANNEL - Windshield	1	30-612 and up
-20	20554-29		CHANNEL ASSEMBLY - Fuselage, Sta. 136	1	30-2 to 30-611 inclusive
-21	20900-00		BULKHEAD - Fuselage, Sta. 86	1	
-22	21748-00		PULLEY BRACKET ASSEMBLY	1	
-23	21560-00		GUSSET ASSEMBLY - Coat hanger support, LH	1	
	21560-01		GUSSET ASSEMBLY - Coat hanger support, RH	1	
-24	20603-11		GUSSET - LH	1	
-25	23253-00		BULKHEAD ASSEMBLY - Fuselage, Sta. 107, LH	1	
	23253-01		BULKHEAD ASSEMBLY - Fuselage, Sta. 107, RH	1	
-26	22565-03		BULKHEAD ASSEMBLY - Fuselage, Sta. 121	1	
-27	20902-00		BULKHEAD	1	
-28	20904-00		CHANNEL ASSEMBLY	1	
-29	20906-00		SUPPORT BRACKET - Left	1	
	20906-01		SUPPORT BRACKET - Right	1	
-30	20603-10		BULKHEAD - Fuselage, Sta. 70 to Sta. 80, LH	1	
	20603-15		BULKHEAD - Fuselage, Sta. 70 to Sta. 80, RH	1	30-2 to 30-611 inclusive
	20603-21		BULKHEAD - Fuselage, Sta. 70 to Sta. 80, RH	1	30-612 and up
-31	20603-16		BULKHEAD - Fuselage, Sta. 70 to Sta. 80, top	1	30-2 to 30-611 inclusive
	20603-09		BULKHEAD - Fuselage, Sta. 70 to Sta. 80, top	1	30-612 and up
-32	21929-00		CONNECTOR TUBE ASSEMBLY - Left	1	
-33	22675-02		BULKHEAD ASSEMBLY - Fuselage, Sta. 105	1	30-2 to 30-611 inclusive
	23675-09		BULKHEAD ASSEMBLY - Fuselage, Sta. 105	1	30-612 and up
-34	22532-04		CHANNEL - Fuselage, Sta. 105, RH	1	30-2 to 30-611 inclusive
	23675-11		CHANNEL - Fuselage, Sta. 105, RH	1	30-612 and up
	20539-24		CHANNEL - Fuselage, Sta. 105, LH	1	30-2 to 30-611 inclusive
	23675-10		CHANNEL - Fuselage, Sta. 105, LH	1	30-612 and up
-35	21930-00		CONNECTOR TUBE ASSEMBLY - Ventilator, LH	1	30-2 to 30-611 inclusive
-36	20539-07		CHANNEL - Fuselage, Sta. 105, top	1	

A - Used on PA-30 with serial numbers 30-2 to 30-852 inclusive, 30-554 to 30-901 inclusive.

When ordering, always specify Part Number, Description and Serial Number of Aircraft



Figure and Index Number	Part Number	Code	NOMENCLATURE	No. Req	SERIAL NUMBERS AFFECTED
9-37	22552-07		ANGLE ASSEMBLY - Fuselage Sta. 105, RH	1	
-38	24177-00		ANGLE ASSEMBLY - Stabilator trim cable alignment	1	
-39	20610-02		CHANNEL - Windshield	1	
-40	20617-07		ANGLE ASSEMBLY - Fuselage Sta. 100 to Sta. 105, top, right	1	
-41	20617-06		ANGLE ASSEMBLY - Fuselage Sta. 80 to Sta. 84, top, right	1	
<p>A - Used on PA-30 with serial numbers 30-2 to 30-852 inclusive, 30-854 to 30-901 inclusive.</p>					

When ordering, always specify Part Number, Description and Serial Number of Aircraft

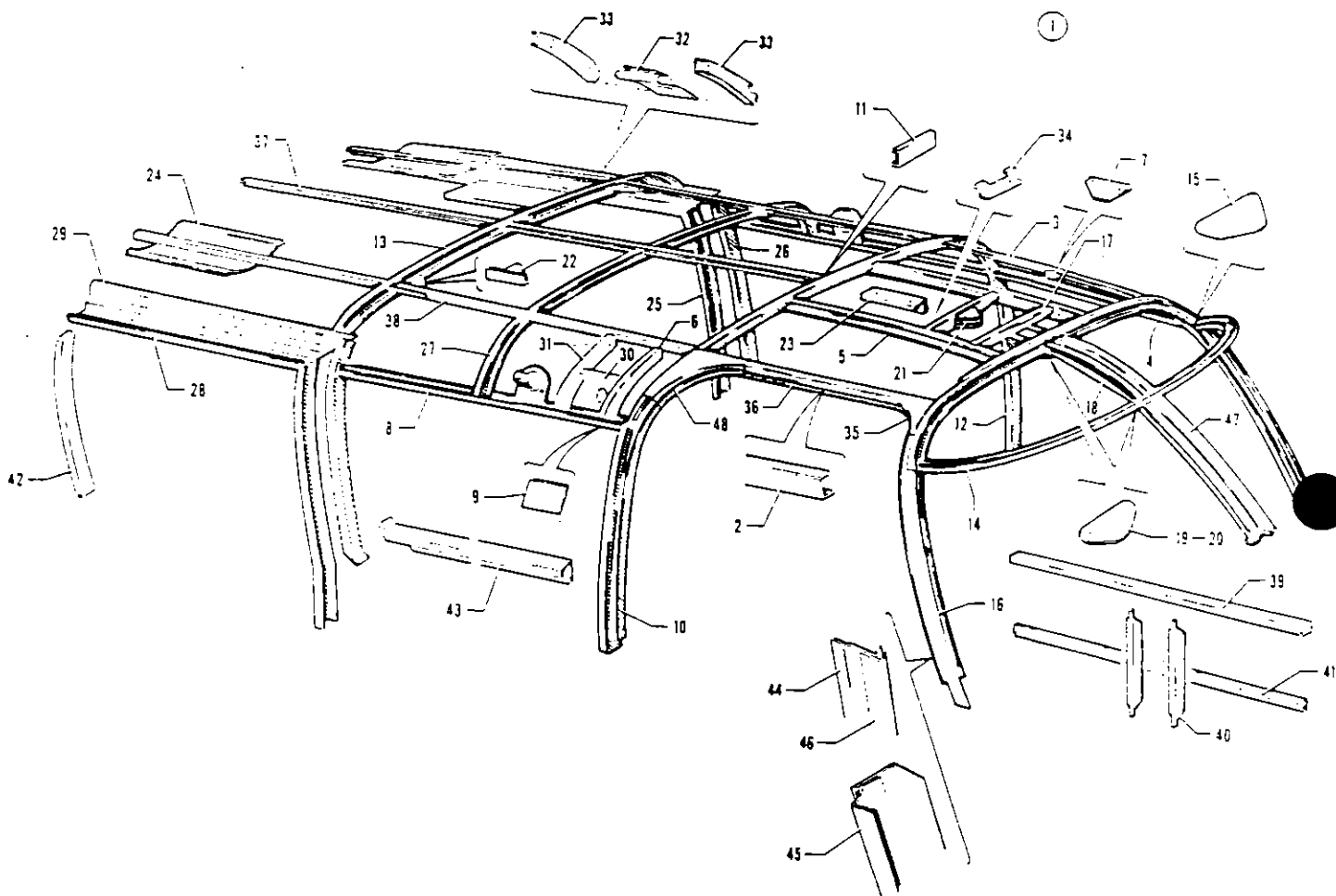

Figure 9A. Fuselage Top Section  
 (PA-30 with Serial Nos. 30-853, 30-902 and up)  
 (PA-39 with Serial Nos. 39-1 and up)

## PIPER PARTS CATALOG

Figure and Index Number	Part Number	Code	NOMENCLATURE	No. Req.	SERIAL NUMBERS AFFECTED
9A-	25355		DRAWING - Fuselage Cabin Top		
-1	25355-00	Y	SECTION ASSEMBLY - Fuselage cabin top	1	30-853, 30-902 to 30-1548
	25355-08	YZ	SECTION ASSEMBLY - Fuselage cabin top	1	30-1549 and up, 39-1 and up
-2	20600-38		* CHANNEL - Fuselage, Sta. 80 to Sta. 105, top, right	1	
-3	20600-24		* STRINGER - Fuselage, Sta. 80 to Sta. 105, top, left	1	
-4	20600-34	Y	* CHANNEL ASSEMBLY - Fuselage, Sta. 78 to Sta. 105, top, left	1	30-853, 30-902 to 30-1548
	25842-00	YZ	* CHANNEL ASSEMBLY - Fuselage, Sta. 78 to Sta. 105, top, left	1	30-1549 and up, 39-1 and up
-5	20600-135		* CHANNEL ASSEMBLY - Fuselage, Sta. 80 to Sta. 105, top, right	1	
	20600-136		* CHANNEL ASSEMBLY - Fuselage, Sta. 80 to Sta. 105, top, left	1	
-6	23283-00		* BULKHEAD ASSEMBLY - Sta. 107, left	1	
	23283-01		* BULKHEAD ASSEMBLY - Sta. 107, right	1	
-7	20457-00		* BRACKET - Wire clamp	1	30-853 and up, 39-1 to 39-145
-8	25334-00	Y	* CHANNEL - Fuselage center section, top, rear, left	1	30-853, 30-902 to 30-1548
	25334-01	Y	* CHANNEL - Fuselage center section, top, rear, right	1	30-853, 30-902 to 30-1548
	25832-00	YZ	* CHANNEL - Fuselage center section, top, rear, left	1	30-1549 and up, 39-1 and up
	25832-01	YZ	* CHANNEL - Fuselage center section, top, rear, right	1	30-1549 and up, 39-1 and up
-9	23284-00		* GUSSET ASSEMBLY - Fuselage top, right	1	
	23285-00		* GUSSET ASSEMBLY - Fuselage top, left	1	
-10	23675-09		* CHANNEL ASSEMBLY - Fuselage, Sta. 105	1	
-11	20539-07		* CHANNEL - Fuselage, Sta. 105, top	1	
-12	23675-10		* CHANNEL - Fuselage, Sta. 105, left	1	
	23675-11		* CHANNEL - Fuselage, Sta. 105, right	1	
-13	25306-07		* CHANNEL ASSEMBLY - Fuselage, Sta. 136, top	1	
-14	20561-03		* CHANNEL ASSEMBLY - Fuselage, Sta. 70 to Sta. 78, top	1	
-15	20603-11		* GUSSET	1	
-16	20603-22		* BULKHEAD ASSEMBLY - Fuselage, Sta. 70 to Sta. 80	1	
-17	20977-03		* BULKHEAD ASSEMBLY - Fuselage, Sta. 80 to Sta. 83, top	1	
-18	20610-03		* CHANNEL - Fuselage, Sta. 70 to Sta. 80, center	1	
-19	20610-04		* GUSSET - Fuselage, Sta. 70, top, center	1	
-20	20610-05		* GUSSET - Fuselage, Sta. 80, top, center	1	
-21	20977-06		* BULKHEAD ASSEMBLY - Fuselage, Sta. 83, top	1	
-22	21560-02		* GUSSET ASSEMBLY - Fuselage, Sta. 136, top, left	1	
	21560-03		* GUSSET ASSEMBLY - Fuselage, Sta. 136, top, right	1	
-23	21307-00		* BRACKET ASSEMBLY - Antenna mounting	1	
-24	25344-00		* CHANNEL - Head guard	2	
-25	25306-04		* CHANNEL - Window, Sta. 136, left	1	
	25306-05		* CHANNEL - Window, Sta. 136, right	1	
-26	25323-02		* BULKHEAD - Sta. 128 to Sta. 133, left	1	
	25323-03		* BULKHEAD - Sta. 128 to Sta. 133, right	1	
-27	25314-03		* CHANNEL ASSEMBLY - Fuselage, Sta. 121	1	

A - Used on PA-30 with serial numbers 30-853, 30-902 and up, and PA-39 with serial numbers 39-1 and up.  
 Y - Used on PA-30 airplanes only.  
 Z - Used on PA-39 airplanes only.

When ordering, always specify Part Number, Description and Serial Number of Aircraft



Figure and Index Number	Part Number	Code	NOMENCLATURE	No. Req.	SERIAL NUMBERS AFFECTED
9A-28	25843-02		CHANNEL - Fuselage support, left	1	
	25843-03		CHANNEL - Fuselage support, right	1	
-29	25341-04		CHANNEL - Fuselage support, left	1	
	25341-05		CHANNEL - Fuselage support, right	1	
-30	27002-00	Z	BRACKET ASSEMBLY - Shoulder harness, left front	1	
	27002-01	Z	BRACKET ASSEMBLY - Shoulder harness, right front	1	
-31	27003-00	Z	BULKHEAD ASSEMBLY - Fuselage, Sta. 113, left	1	
	27003-01	Z	BULKHEAD ASSEMBLY - Fuselage, Sta. 113, right	1	
-32	27001-00	Z	BRACKET ASSEMBLY - Shoulder harness, center	2	
-33	27005-00	Z	BULKHEAD - Center shoulder harness, left rear, right front	2	
	27005-01	Z	BULKHEAD - Center shoulder harness, left front, right rear	2	
-34	24177-02		ANGLE ASSEMBLY - Stabilator trim cable alignment	1	
-35	20617-06		ANGLE ASSEMBLY - Fuselage, Sta. 80 to Sta. 84, top, right	1	
-36	20600-96		ANGLE ASSEMBLY - Fuselage, Sta. 105, top, right	1	
-37	25355-07		STRINGER - Fuselage, Sta. 136 to Sta. 157, top	3	
-38	25355-04		STRINGER - Fuselage, Sta. 105 to Sta. 136, top	3	
-39	25821-00		CHANNEL ASSEMBLY - Sta. 66 to Sta. 105, left	1	
-40	22421-00		CHANNEL ASSEMBLY - Armrest support	2	
-41	20600-125		CHANNEL - Fuselage, Sta. 70 to Sta. 105, LH	1	
-42	25321-00		CHANNEL - Rear window	1	
	25321-01		CHANNEL - Rear window	1	
-43	25332-00		CHANNEL - Center window, left	1	30-853, 30-902 to 30-1548
	25332-01		CHANNEL - Center window, right	1	30-853, 30-902 to 30-1548
	26099-00		CHANNEL - Center window, left	1	30-1549 and up
	25829-01		CHANNEL - Center window, right	1	30-1549 and up
-44	20603-08		STRIP - Fuselage, Sta. 70 to Sta. 78, top, left	1	
	20603-06		STRIP - Fuselage, Sta. 70 to Sta. 78, top, right	1	
-45	20603-12		ANGLE ASSEMBLY - Fuselage, Sta. 70 to Sta. 78, top, right	1	
-46	23288-00		STRIP - Moulding retainer	2	
-47	20610-02		CHANNEL - Fuselage, Sta. 53 to Sta. 70, top, center	1	
-48	20617-07		ANGLE ASSEMBLY - Fuselage, Sta. 100 to Sta. 105, top, right	1	

A - Used on PA-30 with serial numbers 30-853, 30-902 and up, and PA-39 with serial numbers 39-1 and up.  
 Y - Used on PA-30 airplanes only.  
 Z - Used on PA-39 airplanes only.

When ordering, always specify Part Number, Description and Serial Number of Aircraft



**1 C1**

**INTENTIONALLY LEFT BLANK**

PIPER PARTS CATALOG

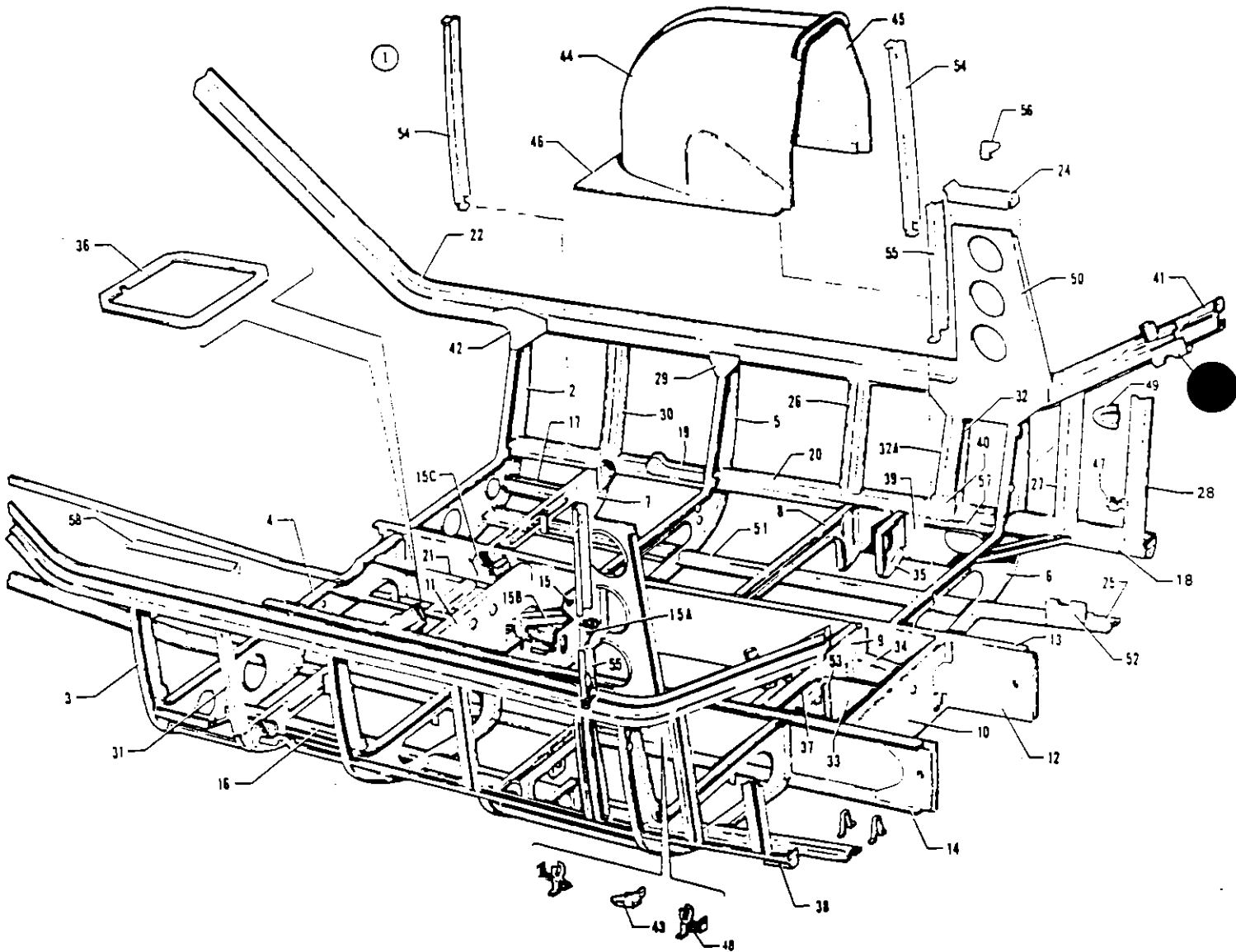

Figure 10. Fuselage Front Frame Assembly

REVISED: MAY 1980

1C2  
Island Enterprises

PA-30  
PA-39



Figure and Index Number	Part Number	Code	NOMENCLATURE	No. Req.	SERIAL NUMBERS AFFECTED
10-	23703		DRAWING - Frame Assembly, Fuselage, Front		
-1	23703-00	B	FRAME ASSEMBLY - Fuselage, front	1	
	23703-03	A	FRAME ASSEMBLY - Fuselage, front	1	
-2	23675-13		BULKHEAD ASSEMBLY - Fuselage, Sta. 105, LH	1	
-3	23675-04		BULKHEAD ASSEMBLY - Fuselage, Sta. 105, RH	1	
-4	23675-05	B	BULKHEAD ASSEMBLY - Fuselage, Sta. 105, bottom	1	
	25477-03	A	BULKHEAD ASSEMBLY - Fuselage, Sta. 105, bottom	1	
-5	23656-02		BULKHEAD ASSEMBLY - Sta. 87, LH	1	
	23656-03		BULKHEAD ASSEMBLY - Sta. 87, RH	1	
-6	23691-06		BULKHEAD ASSEMBLY - Sta. 66, LH	1	
	23691-05		BULKHEAD ASSEMBLY - Sta. 66, RH	1	
-7	23600-06		BULKHEAD ASSEMBLY - Fuselage, Sta. 96, LH	1	
	23600-07		BULKHEAD ASSEMBLY - Fuselage, Sta. 96, RH	1	
-8	20570-06		BULKHEAD ASSEMBLY - Fuselage, Sta. 77, bottom, left	1	
	20570-07		BULKHEAD ASSEMBLY - Fuselage, Sta. 77, bottom, right	1	
-9	23617-00		BULKHEAD ASSEMBLY - Fuselage, Sta. 68	1	
-10	23617-02		BULKHEAD ASSEMBLY - Fuselage, Sta. 59	1	
-11	23645-00		BULKHEAD ASSEMBLY - Fuselage, Sta. 92	1	
-12	23626-00	B	BEAM ASSEMBLY - Longitudinal fuselage, Sta. 49 to Sta. 105, LH	1	
	26355-00	A	BEAM ASSEMBLY - Longitudinal fuselage, Sta. 49 to Sta. 105, LH	1	
	23626-01	B	BEAM ASSEMBLY - Longitudinal fuselage, Sta. 49 to Sta. 105, RH	1	
	26355-01	A	BEAM ASSEMBLY - Longitudinal fuselage, Sta. 49 to Sta. 105, RH	1	
-13	20557-06		ANGLE - Beam, upper, LH	1	
	20557-07		ANGLE - Beam, upper, RH	1	
-14	20557-08		ANGLE - Beam, bottom, LH	1	
	20557-09		ANGLE - Beam, bottom, RH	1	
-15	22631-02		CHANNEL ASSEMBLY - Fuselage, Sta. 87	1	
-15a	21760-00		LUG - Transmission attachment	1	
-15b	20954-00		CHANNEL ASSEMBLY - Gear motor support	1	
-15c	25876-00		FITTING ASSEMBLY - Front seat belt attachment, left	1	
	25876-01		FITTING ASSEMBLY - Front seat belt attachment, right	1	
-16	22629-02		CHANNEL - Fuselage front	2	
-17	20600-62		CHANNEL - Fuselage front, LH	1	
	20600-63		CHANNEL - Fuselage front, RH	1	
-18	22272-10		STRINGER ASSEMBLY - Fuselage, Sta. 49 to Sta. 66, LH	1	
	22272-09		STRINGER ASSEMBLY - Fuselage, Sta. 49 to Sta. 66, RH	1	

A - Used on PA-30 with serial numbers 30-1717, 30-1745 and up, and PA-39 with serial numbers 39-1 and up.  
 B - Used on PA-30 with serial numbers 30-2 to 30-1716 inclusive, 30-1718 to 30-1744 inclusive.

When ordering, always specify Part Number, Description and Serial Number of Aircraft

PIPER PARTS CATALOG

Figure and Index Number	Part Number	Code	NOMENCLATURE	No. Req.	SERIAL NUMBERS AFFECTED
10-19	23690-04		* STRINGER ASSEMBLY - Fuselage, Sta. 87 to Sta. 105, LH	1	
	23690-05		* STRINGER ASSEMBLY - Fuselage, Sta. 87 to Sta. 105, RH	1	
-20	23743-04		* STRINGER ASSEMBLY - Fuselage, Sta. 66 to Sta. 87, LH	1	
	23743-05		* STRINGER ASSEMBLY - Fuselage, Sta. 66 to Sta. 87, RH	1	
-21	23839-04		* ANGLE ASSEMBLY - Floorboard support, LH	1	
	23839-02		* ANGLE - Floorboard support, RH	1	
-22	22232-03	A	CHANNEL - Fuselage, Sta. 49 to Sta. 130, left	1	
	25383-12	B	CHANNEL - Fuselage, Sta. 49 to Sta. 130, left	1	
	20600-21	A	CHANNEL - Fuselage, Sta. 49 to Sta. 130, right	1	
	25383-13	B	CHANNEL - Fuselage, Sta. 49 to Sta. 130, right	1	
-23	20443-00	C	BRACKET ASSEMBLY - Rudder pedal torque tube bearing, left	1	
	20443-01	C	BRACKET ASSEMBLY - Rudder pedal torque tube bearing, right	1	
	27111-00	Z	BRACKET ASSEMBLY - Rudder pedal torque tube bearing, left	1	39-84 and up
	27111-01	Z	BRACKET ASSEMBLY - Rudder pedal torque tube bearing, right	1	39-84 and up
-24	26860-00		CHANNEL - Fuselage side, Sta. 66 to Sta. 70, left	1	
	26860-01		CHANNEL - Fuselage side, Sta. 66 to Sta. 70, right	1	
-25	20600-50		CHANNEL - Fuselage, Sta. 49 to Sta. 66, left	1	
	20600-51		CHANNEL - Fuselage, Sta. 49 to Sta. 66, right	1	
-26	23820-08		CHANNEL - Sta. 78, left	1	
	23820-09		CHANNEL - Sta. 78, right	1	
-27	23820-10		CHANNEL - Sta. 61, left	1	
	23820-11		CHANNEL - Sta. 61, right	1	
-28	23820-12		CHANNEL - Sta. 54, left	1	
	23820-13		CHANNEL - Sta. 54, right	1	
-29	20601-05		GUSSET - Fuselage, Sta. 87 and Sta. 96	3	
-30	23660-04		CHANNEL - Fuselage, Sta. 96	1	
-31	23660-05		BULKHEAD - Fuselage, Sta. 96	1	
-32	22572-10		BULKHEAD ASSEMBLY - Fuselage, Sta. 70, left, forward	1	
	22572-11		BULKHEAD ASSEMBLY - Fuselage, Sta. 70, right, forward	1	
-32a	22572-12		BULKHEAD ASSEMBLY - Fuselage, Sta. 70, left, aft	1	
	22572-13		BULKHEAD ASSEMBLY - Fuselage, Sta. 70, right, aft	1	
-33	23602-00		BULKHEAD ASSEMBLY	1	
-34	21155-03		PLATE ASSEMBLY - Landing gear retraction	1	
-35	21953-00		BRACKET ASSEMBLY - Seat track support, left	1	
	21953-01		BRACKET ASSEMBLY - Seat track support, right	1	
-36	22257-00		PLATE ASSEMBLY - Fuel strainer access reinforcement	1	
-37	23603-00	Y	ANGLE ASSEMBLY - Circuit protector panel	1	30-2 to 30-1254 inclusive
	23603-04	YZ	ANGLE ASSEMBLY - Circuit protector panel	1	30-1255 and up, 39-1 and up

A - Used on PA-30 with serial numbers 30-2 to 30-852 inclusive, 30-854 to 30-901 inclusive.  
 B - Used on PA-30 with serial numbers 30-853, 30-902 and up, and PA-39 with serial numbers 39-1 and up  
 C - Used on PA-30 with serial numbers 30-2 and up, and PA-39 with serial numbers 39-1 to 39-83 inclusive.  
 Y - Used on PA-30 airplanes only.  
 Z - Used on PA-39 airplanes only

When ordering, always specify Part Number, Description and Serial Number of Aircraft



Figure and Index Number	Part Number	Code	NOMENCLATURE	No. Req.	SERIAL NUMBERS AFFECTED
10-38	23615-00		FITTING ASSEMBLY - Landing gear mount lower attachment, left	1	
	23615-01		FITTING ASSEMBLY - Landing gear mount lower attachment, right	1	
-39	23616-00		GUSSET - Fuselage	1	
	23616-01		GUSSET - Fuselage	1	
-40	23633-00		GUSSET - Fuselage	2	
-41	23618-00		FITTING ASSEMBLY - Landing gear mount upper attachment, left	1	
	23618-01		FITTING ASSEMBLY - Landing gear mount upper attachment, right	1	
-42	23643-00		GUSSET - Fuselage, Sta. 105, side left	1	
	23643-01		GUSSET - Fuselage, Sta. 105, side, right	1	
-43	26514-00	D	BRACKET ASSEMBLY - Landing gear safety lock	1	
-44	23697-05		COVER ASSEMBLY - Nose wheel	1	
-45	23697-02		COVER - Left	1	
	23697-03		COVER - Right	1	
-46	23697-04		PLATE - Nose wheel cover	1	
-47	24336-00		BRACKET ASSEMBLY - Panel attachment	2	
-48	23972-00		BRACKET ASSEMBLY - Landing gear retraction lever	2	
-49	23828-00		FAIRING - Control cable	2	
-50	20613-03		GUSSET PLATE - Sta. 66, left	1	
	20613-04		GUSSET PLATE - Sta. 66, right	1	
-51	22607-16		CHANNEL - Fuselage, Sta. 66 to Sta. 87, left	1	
	22607-22		CHANNEL - Fuselage, Sta. 66 to Sta. 87, right	1	
-52	25675-00	C	BRACKET - Pitch servo mounting	1	
	26622-00	B	BRACKET - Pitch servo mounting	1	
-53	23805-00	B	ANGLE - Shunt and fuse panel	1	
-54	20612-04	A	CHANNEL - Fuselage upper, Sta. 66, left	1	
	26513-02	B	CHANNEL ASSEMBLY - Fuselage upper, Sta. 66, left	1	
	20612-05		CHANNEL - Fuselage upper, Sta. 66, right	1	
-55	20604-12	A	CHANNEL ASSEMBLY - Fuselage upper, Sta. 70, left	1	
	26509-03	B	CHANNEL ASSEMBLY - Fuselage upper, Sta. 70, left	1	
	20604-10		CHANNEL ASSEMBLY - Fuselage upper, Sta. 70, right (with hinge brackets)	1	
-56	26578-00	B	BRACKET - Gasper attachment	2	
-57	25162-00		ANGLE ASSEMBLY - Left	1	
	25162-01		ANGLE ASSEMBLY - Right	1	
-58	20600-99		ANGLE ASSEMBLY - Right, Sta. 70.875 to Sta. 105.375	1	

A - Used on PA-30 with serial numbers 30-2 to 30-1716 inclusive, 30-1718 to 30-1744 inclusive.  
 B - Used on PA-30 with serial numbers 30-1717, 30-1745 and up, and PA-39 with serial numbers 39-1 and up.  
 C - Used on PA-30 with serial numbers 30-1255 to 30-1716 inclusive, 30-1718 to 30-1744 inclusive.  
 D - Used on PA-30 with serial numbers 30-1717, 30-1745 and up, and PA-39 with serial numbers 39-1 and up. Also used on PA-30 with serial numbers 30-2 to 30-1716, 30-1718 to 30-1744 incl. if Landing Gear Emergency Extension Security Installation Kit 760 627 has been installed per Service Spares Letter SP-325.

When ordering, always specify Part Number, Description and Serial Number of Aircraft

**1 C6**  
INTENTIONALLY LEFT BLANK

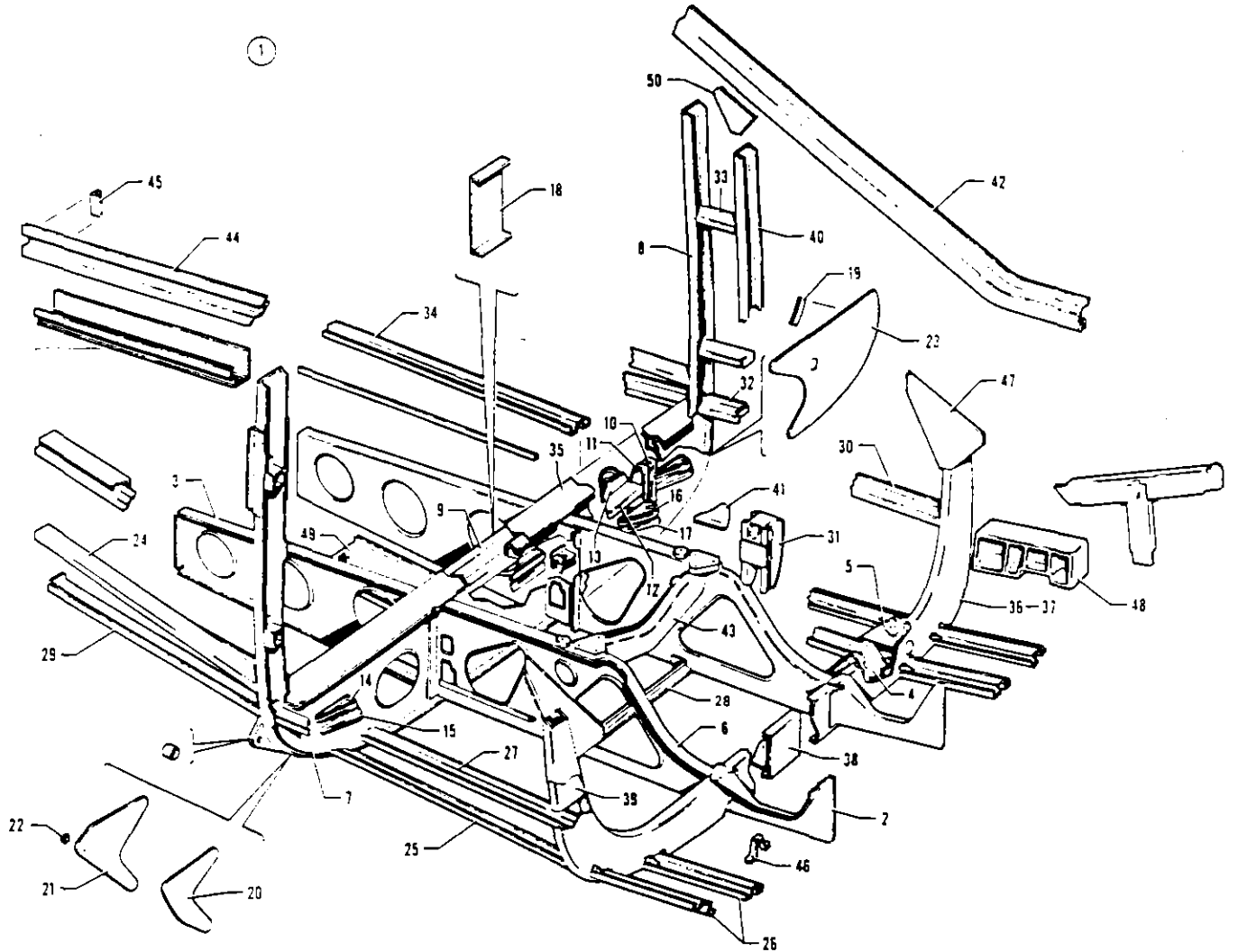

Figure 11. Fuselage Rear Frame Assembly  
(PA-30 with Serial Nos. 30-2 to 30-852, 30-854 to 30-901 inclusive)



Figure and Index Number	Part Number	Code	NOMENCLATURE	No. Req.	SERIAL NUMBERS AFFECTED
11-	22620		DRAWING - Frame Assembly, Fuselage, Rear		
-1	22620-00	B	FRAME ASSEMBLY - Fuselage, rear	1	30-2 to 30-589 inclusive
	22620-21		FRAME ASSEMBLY - Fuselage, rear	1	
-2	20455-00		BULKHEAD - Fuselage bottom, Sta. 105 to Sta. 113, left	1	
	20455-01		BULKHEAD - Fuselage bottom, Sta. 105 to Sta. 113, right	1	
-3	22562-00		BULKHEAD ASSEMBLY - Fuselage bottom, Sta. 136 to Sta. 157, left	1	
	22562-01		BULKHEAD ASSEMBLY - Fuselage bottom, Sta. 136 to Sta. 157, right	1	
-4	20477-00		BRACKET - Pulley, Sta. 113, center, left	1	
-5	20515-00		BRACKET - Pulley, Sta. 113, outboard, left	1	
	20516-00		BRACKET - Pulley, Sta. 113, inboard, left	1	
-6	20546-04		BULKHEAD ASSEMBLY - Fuselage bottom, Sta. 113 to Sta. 136, left	1	
	20546-05		BULKHEAD ASSEMBLY - Fuselage bottom, Sta. 113 to Sta. 136, right	1	
-7	22606-05		BULKHEAD ASSEMBLY - Fuselage, Sta. 136	1	
-8	20554-02		CHANNEL - Fuselage, Sta. 136, left	1	
	22606-03		CHANNEL - Fuselage, Sta. 136, right	1	
-9	20554-05		CHANNEL - Reinforcement	1	
-10	20442-02		BRACKET - Pulley, Sta. 136, rear, left	1	
-11	20442-03		BRACKET - Pulley, Sta. 136, rear, left	1	
-12	20497-00		BRACKET - Pulley, Sta. 136, rear, left	1	
-13	20498-00		BRACKET - Pulley, Sta. 136, rear, left	1	
-14	20504-02		BRACKET - Pulley, Sta. 136, front, left	1	
	20504-03		BRACKET - Pulley, Sta. 136, front, right	1	
-15	20504-04		BRACKET - Pulley, Sta. 136, front	2	
-16	20505-02		BRACKET - Pulley, Sta. 136, front, left	1	
-17	20505-03		BRACKET - Pulley, Sta. 136, front, left	1	
-18	20554-12	CHANNEL - Splice	1		
-19	20554-16	ANGLE - Left	1		
	20554-17	ANGLE - Right	1		
-20	23662-00	PLATE	2		
-21	23663-00	FITTING ASSEMBLY	2		
-22	80022-97	BUSHING - Rear spar attachment	1		
-23	23665-02	DOUBLER - Fuselage, Sta. 136, left	1		
	23664-02	DOUBLER - Fuselage, Sta. 136, right	1		
-24	22620-06	STRINGER - Fuselage bottom, Sta. 136 to Sta. 157, left	1		
	20600-75	STRINGER - Fuselage bottom, Sta. 136 to Sta. 157, right	1		

A - Used on PA-30 with serial numbers 30-2 to 30-852 inclusive, 30-854 to 30-901 inclusive.  
B - Used on PA-30 with serial numbers 30-590 to 30-852 inclusive, 30-854 to 30-901 inclusive.

When ordering, always specify Part Number, Description and Serial Number of Aircraft





Figure and Index Number	Part Number	Code	NOMENCLATURE	No. Req.	SERIAL NUMBERS AFFECTED
11-25	22020-10		STRINGER - Fuselage bottom, Sta. 113 to Sta. 136, left	1	
	22020-11		STRINGER - Fuselage bottom, Sta. 113 to Sta. 136, right	1	
-26	20000-50		STRINGER CHANNEL - Fuselage bottom, Sta. 105 to Sta. 113	4	
-27	20000-55		STRINGER CHANNEL - Fuselage bottom, Sta. 113 to Sta. 136, left	1	
	20000-59		STRINGER CHANNEL - Fuselage bottom, Sta. 113 to Sta. 136, right	1	
-28	20000-101		STRINGER ASSEMBLY - Fuselage, Sta. 124	1	
-29	20000-132		STRINGER ASSEMBLY - Fuselage, Sta. 136 to Sta. 157, left	1	
	20000-131		STRINGER ASSEMBLY - Fuselage, Sta. 136 to Sta. 157, right	1	
-30	22620-04	B	STRINGER - Fuselage side, Sta. 113 to Sta. 136, left	1	30-2 to 30-589 inclusive
	22620-23		STRINGER - Fuselage side, Sta. 113 to Sta. 136, left	1	
	22620-05		STRINGER - Fuselage side, Sta. 113 to Sta. 136, right	1	30-2 to 30-589 inclusive
	22620-24	B	STRINGER - Fuselage side, Sta. 113 to Sta. 136, right	1	
-31	20490-00		BRACKET ASSEMBLY - Rear seat support	1	
-32	22020-14		STRINGER ASSEMBLY - Fuselage, Sta. 132 to Sta. 136, left	1	
	22020-15		STRINGER ASSEMBLY - Fuselage, Sta. 132 to Sta. 136, right	1	
-33	22004-00		CHANNEL - Fuselage, Sta. 132 to Sta. 136, right bottom	1	
	22004-01		CHANNEL - Fuselage, Sta. 132 to Sta. 136, right top, left top and bottom	3	
-34	22020-08		STRINGER - Fuselage bottom, Sta. 136 to Sta. 157, left	1	
	22020-09		STRINGER - Fuselage bottom, Sta. 136 to Sta. 157, right	1	
-35	20554-20		STRIP ASSEMBLY - Bulkhead, Sta. 136	1	
-36	22015-04		BULKHEAD ASSEMBLY - Fuselage, Sta. 113	1	
-37	22015-02		CHANNEL - Left	1	
	22015-03		CHANNEL - Right	1	
-38	22015-05		PLATE - Splice	1	
-39	20010-04		DOUBLER - Left	1	
	20010-05		DOUBLER - Right	1	
-40	22000-02		BULKHEAD - Fuselage, Sta. 132, left	1	
	22000-03		BULKHEAD - Fuselage, Sta. 132, right	1	
-41	22537-00		GUSSET - Fuselage, Sta. 132	2	
-42	22232-03		CHANNEL - Fuselage, Sta. 49 to Sta. 130, left	1	
	20000-21		CHANNEL - Fuselage, Sta. 49 to Sta. 130, right	1	
-43	20445-00		BULKHEAD - Seat support, Sta. 123	1	
-44	20000-22		CHANNEL - Fuselage, Sta. 136 to Sta. 157, left	1	
	20000-23		CHANNEL - Fuselage, Sta. 136 to Sta. 157, right	1	

A - Used on PA-30 with serial numbers 30-2 to 30-852 inclusive. 30-854 to 30-901 inclusive.  
 B - Used on PA-30 with serial numbers 30-590 to 30-852 inclusive. 30-854 to 30-901 inclusive.

When ordering, always specify Part Number, Description and Serial Number of Aircraft

FUSELAGE REAR FRAME ASSEMBLY  
(See Code "A")



SECTION II  
Fuselage Group

Figure and Index Number	Part Number	Code	NOMENCLATURE	No. Req	SERIAL NUMBERS AFFECTED
11-45	20c4c-00		ANGLE - Fuselage channel attachment, Sta. 157	1	
-46	2132s-02		BRACKET - Radio cable clamp	2	
	2132s-03		BRACKET - Radio cable clamp	1	
-47	20c1c-06		GUSSET - Bulkhead, Sta. 113, left	1	
	20c1c-07		GUSSET - Bulkhead, Sta. 113, right	1	
-48	20411-00		FITTING - Main spar top attachment, left	1	
	20411-01		FITTING - Main spar top attachment, right	1	
-49	30304-00		BRACKET ASSEMBLY - Antenna mounting	1	
-50	2258c-00		GUSSET - Fuselage bulkhead	2	
			<p>A - Used on PA-30 with serial numbers 30-2 to 30-852 inclusive. 30-854 to 30-901 inclusive.</p>		

When ordering, always specify Part Number, Description and Serial Number of Aircraft

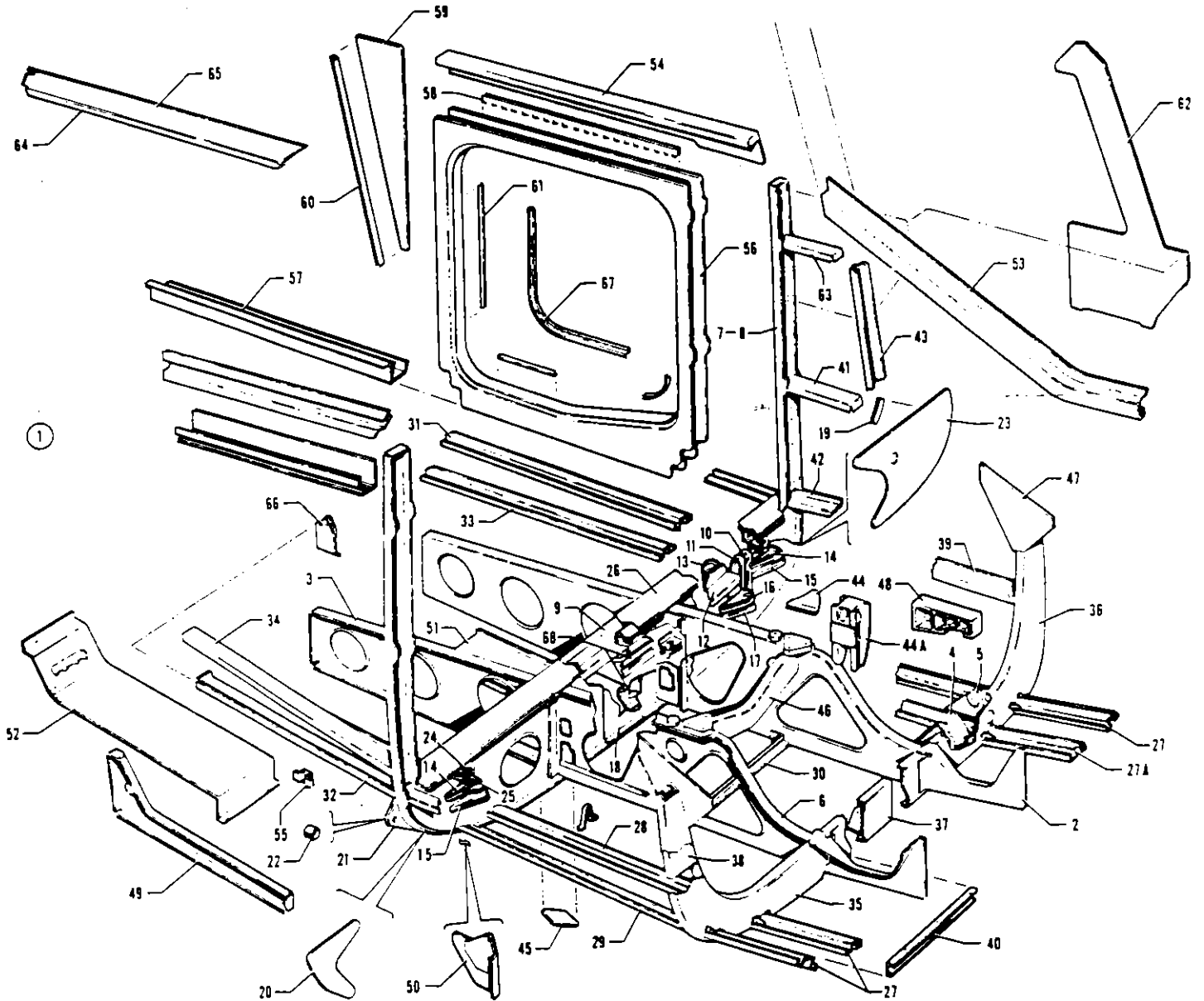

Figure 11A. Fuselage Rear Frame Assembly  
 (PA-30 with Serial Nos. 30-853, 30-902 and up)  
 (PA-39 with Serial Nos. 39-1 and up)



Figure and Index Number	Part Number	Code	NOMENCLATURE	No. Req.	SERIAL NUMBERS AFFECTED
11A-	25333		DRAWING - Frame Assembly, Fuselage, Rear		
-1	25333-00	C	FRAME ASSEMBLY - Fuselage, rear	1	
	25333-17	D	FRAME ASSEMBLY - Fuselage, rear	1	
-2	20455-00		BULKHEAD - Fuselage bottom, Sta. 105 to Sta. 113, left	1	
	20455-01		BULKHEAD - Fuselage bottom, Sta. 105 to Sta. 113, right	1	
-3	22562-00		BULKHEAD ASSEMBLY - Fuselage bottom, Sta. 136 to Sta. 157, left	1	
	22562-01		BULKHEAD ASSEMBLY - Fuselage bottom, Sta. 136 to Sta. 157, right	1	
-4	20477-00		BRACKET - Pulley, Sta. 113, center, left	1	
-5	20515-00		BRACKET - Pulley, Sta. 113, outboard, left	1	
	20516-00		BRACKET - Pulley, Sta. 113, inboard, left	1	
-6	25256-00	C	BULKHEAD ASSEMBLY - Fuselage bottom, Sta. 113 to Sta. 136, left	1	
	26614-00	D	BULKHEAD ASSEMBLY - Fuselage bottom, Sta. 113 to Sta. 136, left	1	
	25256-01		BULKHEAD ASSEMBLY - Fuselage bottom, Sta. 113 to Sta. 136, right	1	
-7	25320-04	Y	BULKHEAD ASSEMBLY - Fuselage, Sta. 136, lower	1	30-853, 30-902 to 30-1254
	25320-05	B	BULKHEAD ASSEMBLY - Fuselage, Sta. 136, lower	1	
	25320-09	D	BULKHEAD ASSEMBLY - Fuselage, Sta. 136, lower	1	
-8	25320-10	Y	CHANNEL - Fuselage, Sta. 136, left	1	30-853, 30-902 to 30-1254
	25320-02	YZ	CHANNEL - Fuselage, Sta. 136, left	1	30-1255 and up, 39-1 and up
	25320-03		CHANNEL - Fuselage, Sta. 136, right	1	
-9	25320-06		CHANNEL - Reinforcement	1	
-10	20442-02		BRACKET - Pulley, Sta. 136, rear, left	1	
-11	20442-03		BRACKET - Pulley, Sta. 136, rear, left	1	
-12	20497-00		BRACKET - Pulley, Sta. 136, rear, left	1	
-13	20498-00		BRACKET - Pulley, Sta. 136, rear, left	1	
-14	20504-02		BRACKET - Pulley, Sta. 136, front, left	1	
	20504-03		BRACKET - Pulley, Sta. 136, front, right	1	
-15	20504-04		BRACKET - Pulley, Sta. 136, front	2	
-16	20505-02		BRACKET - Pulley, Sta. 136, front, left	1	
-17	20505-03		BRACKET - Pulley, Sta. 136, front, left	1	
-18	20554-12		CHANNEL - Splice	1	
-19	20554-16		ANGLE - Left	1	
	20554-17		ANGLE - Right	1	
-20	23662-00		PLATE	2	
-21	23663-00		FITTING ASSEMBLY	2	
-22	80022-07		BUSHING - Rear spar attachment	1	

A - Used on PA-30 with serial numbers 30-853, 30-902 and up, and PA-39 with serial numbers 39-1 and up.  
 B - Used on PA-30 with serial numbers 30-1255 to 30-1716 inclusive, 30-1718 to 30-1744 inclusive.  
 C - Used on PA-30 with serial numbers 30-853, 30-902 to 30-1716 inclusive, 30-1718 to 30-1744 inclusive.  
 D - Used on PA-30 with serial numbers 30-1717, 30-1745 and up, and PA-39 with serial numbers 39-1 and up.  
 Y - Used on PA-30 airplanes only.  
 Z - Used on PA-39 airplanes only.

When ordering, always specify Part Number, Description and Serial Number of Aircraft



Figure and Index Number	Part Number	Code	NOMENCLATURE	No. Req.	SERIAL NUMBERS AFFECTED
11A-23	23003-02		DOUBLER - Fuselage, Sta. 136, left	1	
	23004-02		DOUBLER - Fuselage, Sta. 136, left	1	
-24	25315-02		BRACKET - Sta. 136, front, left	1	
	25315-03		BRACKET - Sta. 136, front, right	1	
-25	25315-04		BRACKET - Sta. 136, front, left	1	
	25315-05		BRACKET - Sta. 136, front, right	1	
-26	25320-05		STRIP - Bulkhead, Sta. 136	1	
-27	20600-50		STRINGER - Fuselage bottom, Sta. 105 to Sta. 113	3	
-27a	26103-00		STRINGER - Fuselage bottom, Sta. 105 to Sta. 113	1	
-28	20600-55		STRINGER - Fuselage bottom, Sta. 113 to Sta. 136, left	1	
	20600-59		STRINGER - Fuselage bottom, Sta. 113 to Sta. 136, right	1	
-29	25333-04		STRINGER - Fuselage bottom, Sta. 113 to Sta. 136, left	1	
	25333-05		STRINGER - Fuselage bottom, Sta. 113 to Sta. 136, right	1	
-30	20600-70		STRINGER - Fuselage bottom, Sta. 122	1	
-31	25333-02		CHANNEL - Fuselage, Sta. 136 to Sta. 157, bottom, left	1	
	25333-03		CHANNEL - Fuselage, Sta. 136 to Sta. 157, bottom, right	1	
-32	25333-12		CHANNEL - Sta. 136 to Sta. 157, right	1	
-33	22e20-05		STRINGER - Fuselage bottom, Sta. 136 to Sta. 157, left	1	
	22e20-09		STRINGER - Fuselage bottom, Sta. 136 to Sta. 157, right	1	
-34	20600-75		CHANNEL - Fuselage bottom, Sta. 136 to Sta. 157, right	1	
-35	22015-04	B	BULKHEAD ASSEMBLY - Fuselage, Sta. 113	1	
	22015-05	C	BULKHEAD ASSEMBLY - Fuselage, Sta. 113	1	
-36	22015-02		CHANNEL - Fuselage, Sta. 113, left	1	
	22015-03		CHANNEL - Fuselage, Sta. 113, right	1	
-37	22015-05		PLATE - Splice	1	
-38	20016-04		DOUBLER - Left	1	
	20016-05		DOUBLER - Right	1	
-39	25310-00		STRINGER - Fuselage side, Sta. 113 to Sta. 136, left	1	
	25310-01		STRINGER - Fuselage side, Sta. 113 to Sta. 136, right	1	
-40	25313-00		CHANNEL ASSEMBLY - Fuselage stiffener, left	1	
	25313-01		CHANNEL ASSEMBLY - Fuselage stiffener, right	1	
-41	25292-02		CHANNEL - Fuselage, left	1	
	25292-03		CHANNEL - Fuselage, right	1	
-42	25274-00		STRINGER ASSEMBLY - Fuselage, left	1	
	25274-01		STRINGER ASSEMBLY - Fuselage, right	1	

A - Used on PA-30 with serial numbers 30-853, 30-902 and up, and PA-39 with serial numbers 39-1 and up.  
 B - Used on PA-30 with serial numbers 30-853, 30-902 to 30-1716 inclusive, 30-1718 to 30-1744 inclusive.  
 C - Used on PA-30 with serial numbers 30-1717, 30-1745 and up, and PA-39 with serial numbers 39-1 and up.

When ordering, always specify Part Number, Description and Serial Number of Aircraft



Figure and Index Number	Part Number	Code	NOMENCLATURE	No. Req.	SERIAL NUMBERS AFFECTED
11A-43	25306-02		BULKHEAD - Sta. 130, left	1	
	25306-03		BULKHEAD - Sta. 130, right	1	
-44	22587-00		GUSSET - Fuselage bulkhead	2	
-44a	25315-00		BRACKET ASSEMBLY - Seat support, center, left	1	
	25315-04		BRACKET ASSEMBLY - Seat support, center, right	1	
-45	25319-00	D	GUSSET - Reinforcement	2	
-46	20445-00		BULKHEAD - Support, Sta. 123	1	
-47	20616-06		GUSSET - Bulkhead, Sta. 113, left	1	
	20616-07		GUSSET - Bulkhead, Sta. 113, right	1	
-48	20411-00		FITTING - Main spar top attachment, left	1	
	20411-01		FITTING - Main spar top attachment, right	1	
-49	25328-01		CHANNEL - Cabin exhaust duct, left	1	
	25328-00		CHANNEL - Cabin exhaust duct, right	1	
-50	25354-00		BRACKET ASSEMBLY - Center seat outboard belt, left	1	
	25354-01		BRACKET ASSEMBLY - Center seat outboard belt, right	1	
-51	25578-00		BRACKET ASSEMBLY - Antenna mounting	1	
-52	25357-00		COVER ASSEMBLY - Cabin air exhaust duct	1	
-53	25383-12		CHANNEL - Fuselage, Sta. 49 to Sta. 130, left	1	
	25383-13		CHANNEL - Fuselage, Sta. 49 to Sta. 130, right	1	
-54	25299-00		CHANNEL - Fuselage, left	1	
	25299-01		CHANNEL - Fuselage, right	1	
-55	21250-00		CLIP - Flap fairing attachment, left	1	
	21250-01		CLIP - Flap fairing attachment, right	1	
-56	25300-02		FRAME - Baggage door, outer	1	
	25300-03		FRAME - Baggage door, inner	1	
-57	25300-06		CHANNEL ASSEMBLY - Baggage door	1	
-58	30406-01		HINGE - Baggage door	1	
-59	25374-02		PLATE - Baggage door	1	
-60	25375-00		ANGLE - Baggage door	1	
-61	25243-03		STRIP - Baggage door moulding seal, top and front	2	
	25243-04		STRIP - Baggage door moulding seal, rear	1	
	25243-02		STRIP - Baggage door moulding seal, bottom	2	
	25244-00		STRIP - Baggage door moulding seal, corner	4	
-62	25306-08		GUSSET - Bulkhead, Sta. 130, left	1	
	25306-09		GUSSET - Bulkhead, Sta. 130, right	1	
-63	25292-04		CHANNEL - Sta. 129 to Sta. 136, left	1	
	25292-05		CHANNEL - Sta. 129 to Sta. 136, right	1	
-64	25843-02		CHANNEL - Fuselage support, left	1	
	25843-03		CHANNEL - Fuselage support, right	1	
-65	25341-04		CHANNEL - Fuselage support, left	1	
	25341-05		CHANNEL - Fuselage support, right	1	
-66	25353-00		BRACKET ASSEMBLY - Outboard belt, rear seat, left	1	
	25353-01		BRACKET ASSEMBLY - Outboard belt, rear seat, right	1	
-67	23183-00		MOULDING - Baggage door	8	
-68	25657-00	B	BRACKET - Roll servo mounting	2	
	26645-00	C	BRACKET - Roll servo mounting, lower	1	
	26646-00	C	BRACKET - Roll servo mounting, upper	1	

A - Used on PA-30 with serial numbers 30-853, 30-902 and up, and PA-39 with serial numbers 39-1 and up.  
 B - Used on PA-30 with serial numbers 30-1255 to 30-1716 inclusive, 30-1718 to 30-1744 inclusive.  
 C - Used on PA-30 with serial numbers 30-1717, 30-1745 and up, and PA-39 with serial numbers 39-1 and up.  
 D - Used on PA-30 with serial numbers 30-853, 30-902 to 30-1716 inclusive, 30-1718 to 30-1744 inclusive.

When ordering, always specify Part Number, Description and Serial Number of Aircraft

**1 C15**

**INTENTIONALLY LEFT BLANK**

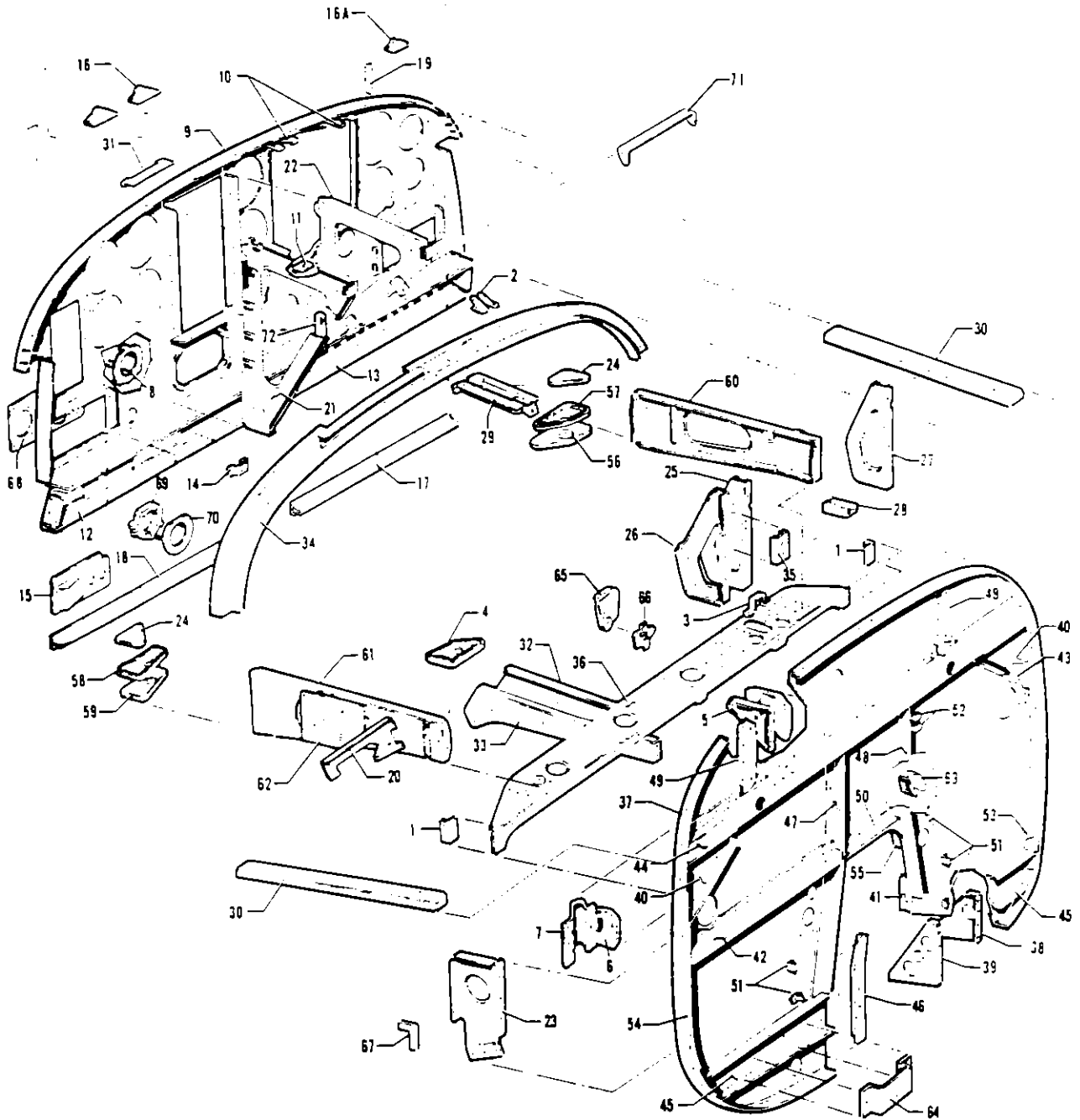

Figure 11B. Fuselage Firewall Assembly





Figure and Index Number	Part Number	Code	NOMENCLATURE	No. Req	SERIAL NUMBERS AFFECTED
11B-	23770	Y	DRAWING - Bulkhead and Instrument Assembly		30-2 to 30-1700 inclusive
	26339	Y	DRAWING - Bulkhead and Instrument Assembly		30-1701 to 30-1716 inclusive.
	26355	B	DRAWING - Bulkhead and Instrument Assembly		30-1718 to 30-1744 inclusive
-1	20388-12		ANGLE	2	
-2	20610-06		ANGLE - LH	1	
	20610-07		ANGLE - RH	1	
-3	20924-00		GUARD - Pulley	1	
-4	20929-00		BRACKET - Stabilator pulley	1	
-5	20930-00		BRACKET - Stabilator pulley, LH	1	
	20930-01		BRACKET - Stabilator pulley, RH	1	
-6	20935-00		BRACKET ASSEMBLY - Stabilator pulley	1	
-7	20936-00		BRACKET - Stabilator pulley	1	
-8	21471-00	Y	BRACKET ASSEMBLY - Control shaft roller	2	30-2 to 30-1701 inclusive
-9	23648-00	AY	PANEL ASSEMBLY - Instrument	1	30-2 to 30-824 inclusive
	25256-00	Y	PANEL ASSEMBLY - Instrument	1	30-825 to 30-1254 inclusive
	25672-00	Y	PANEL ASSEMBLY - Instrument	1	30-1255 to 30-1400 inclusive
	25794-00	C	PANEL ASSEMBLY - Instrument	1	
	26489-00	Y	PANEL ASSEMBLY - Instrument	1	30-1717, 30-1745 to 30-1780
	26490-03	E	PANEL ASSEMBLY - Instrument	1	
	27277-03	Z	PANEL ASSEMBLY - Instrument	1	39-146 and up
-10	19530-00	D	BRACKET - Gyro panel mounting	2	
-11	22050-00	D	BRACKET ASSEMBLY - Gyro panel mounting	1	
-12	23648-03	D	PANEL - Instrument, RH	1	
	26442-00	S	PANEL ASSEMBLY - Switch and circuit breaker, RH	1	
-13	23648-04	D	PANEL - Instrument, LH	1	
	26444-00	F	PANEL ASSEMBLY - Switch, LH	1	
	26444-03	Z	PANEL ASSEMBLY - Switch, LH	1	39-146 and up
-14	23905-00	D	BRACKET - Flap switch support	1	
-15	26427-00	B	BRACKET - Heater air control	1	
-16	26445-00	S	BRACKET - Shock mount	2	
-10a	26445-00	F	BRACKET - Shock mount	1	
	27275-00	Z	BRACKET - Shock mount	1	39-146 and up

A - If Kit 756 909 has been installed, order part for PA-30 with serial numbers 30-825 to 30-1254 inclusive.  
 B - Used on PA-30 with serial numbers 30-1717, 30-1745 and up, and PA-39 with serial numbers 39-1 and up.  
 C - Used on PA-30 with serial numbers 30-1401 to 30-1716 inclusive, 30-1718 to 30-1744 inclusive.  
 D - Used on PA-30 with serial numbers 30-2 to 30-1716 inclusive, 30-1718 to 30-1744 inclusive.  
 E - Used on PA-30 with serial numbers 30-1781 and up, and PA-39 with serial numbers 39-1 to 39-145 incl.  
 F - Used on PA-30 with serial numbers 30-1717, 30-1745 and up, and PA-39 with serial numbers 39-1 to 39-145 inclusive.  
 Y - Used on PA-30 airplanes only.  
 Z - Used on PA-39 airplanes only.

When ordering, always specify Part Number, Description and Serial Number of Aircraft



Figure and Index Number	Part Number	Code	NOMENCLATURE	No. Req.	SERIAL NUMBERS AFFECTED
11B-17	26494-02	B	STRIP ASSEMBLY - Instrument panel cover retainer, LH	1	
-16	26494-03	B	STRIP ASSEMBLY - Instrument panel cover retainer, RH	1	
-19	27279-00	Z	BRACKET - Panel reinforcement	1	39-146 and up
-20	32254-00	YZ	BRACKET - Altitude selector mounting	1	30-1401 and up, 39-1 and up
-21	22191-03	D	BRACKET ASSEMBLY - Radio support, right	1	
	26467-00	Y	BRACKET ASSEMBLY - Radio support, right	1	30-1717, 30-1745 to 30-1780
	26810-00	A	BRACKET ASSEMBLY - Radio support, right	1	
	27275-00	Z	BRACKET ASSEMBLY - Radio support, right	1	39-146 and up
-22	23400-00	D	BRACKET ASSEMBLY - Radio support, left	1	
	26388-00	Y	BRACKET ASSEMBLY - Radio support, left	1	30-1717, 30-1745 to 30-1780
	26813-00	CYZ	BRACKET ASSEMBLY - Radio support, left	1	
	26813-03	Z	BRACKET ASSEMBLY - Radio support, left	1	39-89 to 39-145 inclusive
	27276-00	Z	BRACKET ASSEMBLY - Radio support, left	1	39-146 and up
-23	24318-00	E	BRACKET ASSEMBLY - Rudder pedal center bearing	1	
	27115-00	Z	BRACKET ASSEMBLY - Rudder pedal center bearing	1	39-84 and up
-24	22054-00		BRACKET ASSEMBLY - Gyro panel mounting	2	
-25	22208-02	E	BRACKET - Brake cylinder, center	1	
	27108-02	Z	BRACKET - Brake cylinder, center	1	39-84 and up
-26	22208-03	E	BRACKET - Brake cylinder, right	1	
	27108-03	Z	BRACKET - Brake cylinder, right	1	39-84 and up
-27	22208-04	E	BRACKET - Brake cylinder, left	1	
	27108-04	Z	BRACKET - Brake cylinder, left	1	39-84 and up
-28	22209-00		CHANNEL - Brake cylinder bracket stiffener	1	
-29	22223-03		CHANNEL ASSEMBLY - Fuselage stiffener	1	
-30	26250-00		CHANNEL ASSEMBLY - Fuselage, LH	1	
	23635-01		CHANNEL - Fuselage, RH	1	
-31	24080-00		HINGE	1	
-32	23707-00	E	BULKHEAD - Quadrant support	1	
	27109-00	Z	BULKHEAD - Quadrant support	1	39-84 and up
-33	24054-00		BULKHEAD - Quadrant support	1	
-34	23644-03		BULKHEAD ASSEMBLY - Sta. 57	1	
-35	22200-00		SUPPORT - Brake hose	2	
-36	22564-00		CHANNEL ASSEMBLY - Pulley support	1	

- A - Used on PA-30 with serial numbers 30-1781 and up, and PA-39 with serial numbers 39-1 to 39-145 inclusive.
- B - Used on PA-30 with serial numbers 30-1717, 30-1745 and up, and PA-39 with serial numbers 39-1 and up.
- C - Used on PA-30 with serial numbers 30-1781 and up, and PA-39 with serial numbers 39-1 to 39-88 inclusive.
- D - Used on PA-30 with serial numbers 30-2 to 30-1716 inclusive, 30-1718 to 30-1744 inclusive.
- E - Used on PA-30 with serial numbers 30-2 and up, and PA-39 with serial numbers 39-1 to 39-83 inclusive.
- Y - Used on PA-30 airplanes only.
- Z - Used on PA-39 airplanes only.

When ordering, always specify Part Number, Description and Serial Number of Aircraft



Figure and Index Number	Part Number	Code	NOMENCLATURE	No. Req	SERIAL NUMBERS AFFECTED
11B-37	23669-00	C	BULKHEAD ASSEMBLY - Fuselage, Sta. 49	1	
	23669-09	B	BULKHEAD ASSEMBLY - Fuselage, Sta. 49	1	
	26482-00	A	BULKHEAD ASSEMBLY - Fuselage, Sta. 49	1	
	26482-04	Z	BULKHEAD ASSEMBLY - Fuselage, Sta. 49	1	39-84 and up
-38	20434-00		BRACKET ASSEMBLY - Pulley	1	
-39	20435-00		BRACKET ASSEMBLY - Pulley	1	
-40	20588-05		GUSSET - RH	1	
	20588-06		GUSSET - LH	1	
-41	20588-10	Y	ANGLE - LH	1	30-2 to 30-987 inclusive
	23623-00	YZ	ANGLE ASSEMBLY - LH	1	30-988 and up, 39-1 and up
-42	23978-00		CHANNEL ASSEMBLY - Fuselage bulkhead stiffener, RH	1	
-43	20566-15		PLATE	2	
-44	22259-07		CHANNEL ASSEMBLY	1	
-45	22576-00		CHANNEL - Firewall reinforcement, LH	1	
	22576-01		CHANNEL - Firewall reinforcement, RH	1	
-46	23625-00	Y	ANGLE - Fuselage bulkhead, RH	1	30-2 to 30-987 inclusive
	23624-00	YZ	ANGLE ASSEMBLY - Fuselage bulkhead, RH	1	30-988 and up, 39-1 and up
-47	23637-00		ANGLE - Fuselage bulkhead, RH	1	
-48	23667-00		ANGLE - Fuselage bulkhead, LH	1	
-49	23824-00		ANGLE - Electrical accessory shelf attachment, right	1	
	23825-00		ANGLE - Electrical accessory shelf attachment, left	1	
-50	23908-00		BRACKET ASSEMBLY - Landing gear mount cover attachment	1	
-51	23909-00		BRACKET ASSEMBLY - Landing gear mount cover attachment	5	
-52	406439		ANGLE - Bracket (A6264-82-3)	2	
-53	23669-04		ANGLE - LH, Sta. 49	1	
	23669-06		ANGLE - RH, Sta. 49	1	
-54	23669-03		ANGLE - LH, Sta. 49	1	
	23669-05		ANGLE - RH, Sta. 49	1	
-55	23669-07		ANGLE - LH, Sta. 49	1	
-56	20919-00		BRACKET - Stabilator pulley	1	
-57	20920-00		BRACKET - Stabilator pulley	1	
-58	22183-00	D	BRACKET - Stabilator pulley	1	
	26387-00	E	BRACKET - Stabilator pulley	1	
-59	22184-00	D	BRACKET - Stabilator pulley	1	
	26383-00	E	BRACKET - Stabilator pulley	1	

A - Used on PA-30 with serial numbers 30-1717, 30-1745 and up, and PA-39 with serial numbers 39-1 to 39-83 inclusive.  
 B - Used on PA-30 with serial numbers 30-853, 30-902 to 30-1716 inclusive, 30-1718 to 30-1744 inclusive.  
 C - Used on PA-30 with serial numbers 30-2 to 30-852 inclusive, 30-854 to 30-901 inclusive.  
 D - Used on PA-30 with serial numbers 30-2 to 30-1716 inclusive, 30-1718 to 30-1744 inclusive.  
 E - Used on PA-30 with serial numbers 30-1717, 30-1745 and up, and PA-39 with serial numbers 39-1 and up.  
 Y - Used on PA-30 airplanes only.  
 Z - Used on PA-39 airplanes only.

When ordering, always specify Part Number, Description and Serial Number of Aircraft



Figure and Index Number	Part Number	Code	NOMENCLATURE	No. Req.	SERIAL NUMBERS AFFECTED
11B-60	22211-04		BULKHEAD ASSEMBLY - Fuselage left longitudinal	1	30-2 and up, 39-1 to 39-119
	22211-06		BULKHEAD ASSEMBLY - Fuselage left longitudinal	1	39-120 and up
-61	22213-00	AY	BULKHEAD ASSEMBLY - Fuselage right longitudinal	1	302- to 30-824 inclusive
	22213-04	C	BULKHEAD ASSEMBLY - Fuselage right longitudinal	1	
-62	26794-00	BC	BRACKET ASSEMBLY - Audio amplifier	1	
-63	23632-00		CLIP - Fuselage bulkhead, LH	1	
	23632-01		CLIP - Fuselage bulkhead, RH	1	
-64	23765-00		BRACKET - Heater fuel valve	1	
-65	24314-00		BRACKET - Rudder trim pulley, rear	1	
-66	24315-00		BRACKET ASSEMBLY - Rudder trim pulley, front	1	
-67	24310-00		BLOCK - Rudder cable rub	1	
-68	25255-00	BYZ	PLATE ASSEMBLY - Instrument panel	1	31-853 and up, 39-1 and up
-69	42536-00	YZ	COLLAR - Control shift	2	30-1701 and up, 39-1 and up
-70	26161-00	YZ	PLATE ASSEMBLY - Control shift collar	2	30-1701 and up, 39-1 and up
-71	27283-00	Z	BRACKET - Radio support	3	39-146 and up
-72	25670-00	D	ANGLE ASSEMBLY - AutoPilot	1	

A - If Kit 756 909 has been installed, order part for PA-30 with serial numbers 30-825 and up, and PA-39 with serial numbers 39-1 and up.  
 B - Used on PA-30 with serial numbers 30-2 to 30-824 inclusive if Kit 756 909 has been installed.  
 C - Used on PA-30 with serial numbers 30-825 and up, and PA-39 with serial numbers 39-1 and up.  
 D - Used on PA-30 with serial numbers 30-1401 to 30-1716 inclusive, 30-1718 to 30-1744 inclusive.  
 Y - Used on PA-30 airplanes only.  
 Z - Used on PA-39 airplanes only.

When ordering, always specify Part Number, Description and Serial Number of Aircraft

**1 C21**

**INTENTIONALLY LEFT BLANK**

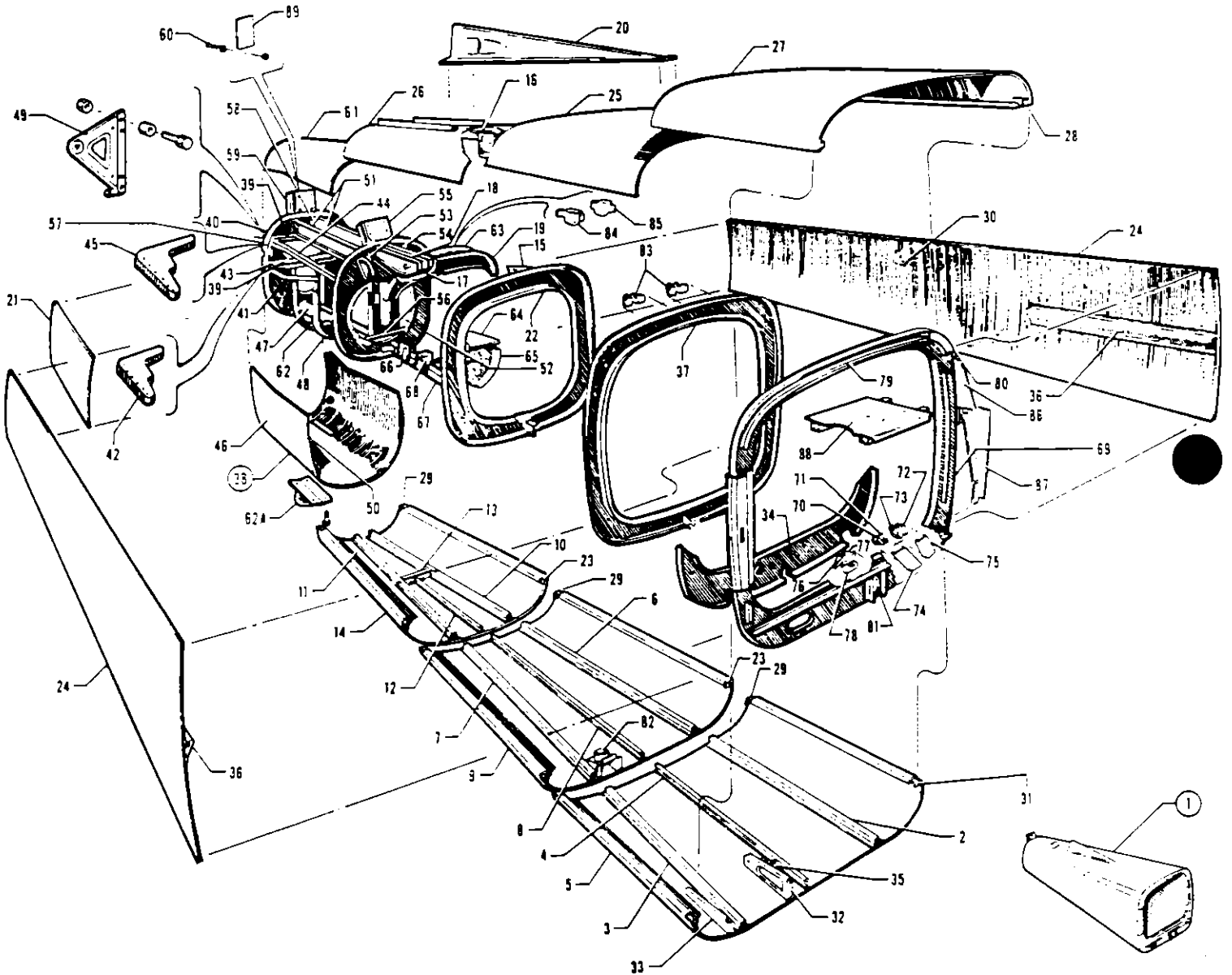

Figure 12. Fuselage Aft Section



Figure and Index Number	Part Number	Code	NOMENCLATURE	No. Req.	SERIAL NUMBERS AFFECTED
12-	24285	A	DRAWING - Fuselage Aft Section		
	25384	B	DRAWING - Fuselage Aft Section		
-1	24285-00	A	FUSELAGE ASSEMBLY - Aft section	1	39-84 and up
	25384-00	C	FUSELAGE ASSEMBLY - Aft section	1	
	25384-04	Z	FUSELAGE ASSEMBLY - Aft section	1	
-2	22573-12		CHANNEL - Fuselage, LH	1	
-3	22573-13		CHANNEL - Fuselage, RH	1	
-4	22573-20		STRINGER ASSEMBLY	1	
-5	22233-02	A	SKIN - Fuselage	1	
	25384-02	B	SKIN - Fuselage	1	
-6	22573-17		CHANNEL ASSEMBLY - Fuselage, LH	1	
-7	22573-18		CHANNEL ASSEMBLY - Fuselage, RH	1	
-8	22573-19		STRINGER ASSEMBLY - Fuselage	1	
-9	20500-03		SKIN - Fuselage	1	
-10	22573-21		CHANNEL ASSEMBLY - Fuselage, LH	1	
-11	22573-22		CHANNEL ASSEMBLY - Fuselage, RH	1	
-12	22573-23		STRINGER ASSEMBLY - Fuselage	1	
-13	20500-15		BULKHEAD - Fuselage (Sta. 226.75)	1	
-14	20500-04		SKIN - Fuselage	1	
-15	17952-00		PLATE - Whip antenna mounting	1	
-16	24292-00		BOX ASSEMBLY - Air distributing	1	
-17	22536-00		BRACKET - Balance weight, upper bumper	1	
-18	22565-00		BRACKET - Stabilator pulley, LH	1	
	22565-01		BRACKET - Stabilator pulley, RH	1	
-19	20500-53		BULKHEAD	1	
-20	24259-00		FIN ASSEMBLY - Dorsal	1	
-21	20432-00		PLATE ASSEMBLY - Fuselage access cover	1	
-22	20452-00		BULKHEAD ASSEMBLY - Fuselage, Sta. 212	1	
-23	20453-00		ANGLE - Fuselage stringer attachment, LH	2	
	20453-01		ANGLE - Fuselage stringer attachment, RH	2	
-24	22233-04		SKIN - Fuselage, LH	1	
	22233-05		SKIN - Fuselage, RH	1	
-25	20500-36		SKIN ASSEMBLY - Fuselage	1	
-26	24288-03		SKIN ASSEMBLY - Fuselage	1	
-27	20500-37		SKIN ASSEMBLY - Fuselage	1	
-28	20548-02		ANGLE - Stringer attachment, LH	1	
	20548-03		ANGLE - Stringer attachment, RH	1	
-29	20548-04		ANGLE - Stringer attachment, LH	3	
	20548-05		ANGLE - Stringer attachment, RH	3	
-30	23558-00		FITTING - Static line vent	2	
-31	21865-01		ANGLE - Stringer attachment, LH	1	
	21865-00		ANGLE - Stringer attachment, RH	1	
-32	22159-00	A	BRACKET ASSEMBLY - Inboard battery box	1	
-33	22190-00	A	BRACKET ASSEMBLY - Outboard battery box	1	

A - Used on PA-30 with serial numbers 30-2 to 30-852 inclusive. 30-854 to 30-901 inclusive.  
 B - Used on PA-30 with serial numbers 30-853, 30-902 and up, and PA-39 with serial numbers 39-1 and up.  
 C - Used on PA-30 with serial numbers 30-853, 30-902 and up, and PA-39 with serial numbers 39-1 to 39-83 inclusive.  
 Z - Used on PA-39 airplanes only.

When ordering, always specify Part Number, Description and Serial Number of Aircraft



Figure and Index Number	Part Number	Code	NOMENCLATURE	No. Req.	SERIAL NUMBERS AFFECTED
12-34	22235-00		BULKHEAD - Fuselage, Sta. 165	1	
-35	22236-00	A	TUBE ASSEMBLY - Battery vent	1	
-36	22240-04	A	CHANNEL ASSEMBLY - Radio shelf support, LH	1	
	25304-04	B	CHANNEL ASSEMBLY - Radio shelf support, LH	1	
	22240-05	A	CHANNEL ASSEMBLY - Radio shelf support, RH	1	
	25304-05	B	CHANNEL ASSEMBLY - Radio shelf support, RH	1	
-37	22246-00		BULKHEAD ASSEMBLY - Fuselage, Sta. 184	1	
-38	22574-11		SKIN ASSEMBLY - Fuselage aft section	1	
-39	22574-07		ANGLE ASSEMBLY - Fuselage aft section, upper	1	
	22574-04		ANGLE ASSEMBLY - Fuselage aft section, lower	1	
-40	20500-31		ANGLE	1	
-41	20500-28		ANGLE - LH	1	
	20500-29		ANGLE - RH	1	
-42	20420-00		FITTING - Stabilator torque tube bearing, lower, LH	1	
	20420-01		FITTING - Stabilator torque tube bearing, lower, RH	1	
-43	22574-08		ANGLE	1	
-44	20500-26		ANGLE - LH	1	
	20500-27		ANGLE - RH	1	
-45	20419-00		FITTING - Stabilator torque tube bearing, upper, LH	1	
	20419-01		FITTING - Stabilator torque tube bearing, upper, RH	1	
-46	22574-02		SKIN	1	
-47	22574-03		CHANNEL	1	
-48	22550-00		BULKHEAD - Fuselage, Sta. 246, LH	1	
	22550-01		BULKHEAD - Fuselage, Sta. 246, RH	1	
-49	22883-00		BRACKET ASSEMBLY - Tab drum support, LH	1	
	22883-01		BRACKET ASSEMBLY - Tab drum support, RH	1	
-50	20988-00		SPACER - Tail skid	2	
-51	20428-00		BULKHEAD - Fuselage aft section, top, LH	1	
	20428-01		BULKHEAD - Fuselage aft section, top, RH	1	
-52	22904-00		BULKHEAD ASSEMBLY - Fuselage, Sta. 239	1	
-53	20409-02		BRACKET - Rudder cable pulley, RH	1	
	20409-03		BRACKET - Rudder cable pulley, RH	1	
-54	20410-02		BRACKET - Rudder cable pulley, LH	1	
	20410-03		BRACKET - Rudder cable pulley, LH	1	
-55	22903-00		CHANNEL ASSEMBLY - Fin attachment	1	
-56	20475-04		BULKHEAD ASSEMBLY - Fuselage, Sta. 239	1	
-57	27559-00		BULKHEAD ASSEMBLY - Sta. 258	1	
-58	20479-07		ANGLE	2	

A - Used on PA-30 with serial numbers 30-2 to 30-852 inclusive, 30-854 to 30-901 inclusive.  
 B - Used on PA-30 with serial numbers 30-853, 30-902 and up, and PA-39 with serial numbers 39-1 and up.

When ordering, always specify Part Number, Description and Serial Number of Aircraft





Figure and Index Number	Part Number	Code	NOMENCLATURE	No. Req.	SERIAL NUMBERS AFFECTED
12-59	27323-00	C	BRACKET ASSEMBLY - Fin attachment	1	
-60	411 532	C	SCREW - (MS35207-263)	1	
	407 674	C	WASHER - (AN960-C10)	1	
	404 887	C	NUT - (MS20365-1032C)	1	
-61	20500-11		SKIN	1	
-62	22549-00		BULKHEAD - Fuselage, Sta. 252, LH	1	
	22549-01		BULKHEAD - Fuselage, Sta. 252, RH	1	
-62a	17667-00		SKID ASSEMBLY - Tail	1	
-63	24326-00		BULKHEAD - Fuselage, Sta. 228, LH	1	
-64	24316-00		GUSSET - Rudder bungee support	1	
-65	24317-00		BULKHEAD - Rudder bungee support	1	
-66	20774-00		BRACKET - Stabilator control cable, lower pulley, LH	1	
	20774-01		BRACKET - Stabilator control cable, lower pulley, RH	1	
-67	20778-00		CHANNEL - Fuselage, reinforcement	1	
-68	22877-00		BRACKET ASSEMBLY - Lower bumper	1	
-69	22555-00	B	BULKHEAD ASSEMBLY - Fuselage, Sta. 157	1	
	25310-00	A	BULKHEAD ASSEMBLY - Fuselage, Sta. 157	1	
-70	20413-00		BRACKET - Inboard rudder cable pulley	1	
-71	20414-00		BRACKET - Inboard rudder cable pulley	1	
-72	20415-00		BRACKET - Outboard rudder cable pulley	1	
-73	20416-00		BRACKET - Outboard rudder cable pulley	1	
-74	20422-00		CHANNEL - Inboard rudder cable pulley bracket	1	
-75	20423-00		CHANNEL - Outboard rudder cable pulley bracket	1	
-76	20424-00		BRACKET - Stabilator cable pulley	1	
-77	20425-00		BRACKET - Stabilator cable pulley	1	
-78	20426-00		BRACKET - Stabilator cable pulley	1	
-79	22263-03		ANGLE	1	
-80	22263-04		PLATE	1	
-81	25308-00	A	BRACKET - Rear seat belt attachment	1	
-82	25366-00	A	BOX ASSEMBLY - Cabin air exhaust	1	
-83	25398-00	A	BRACKET - Pulley	1	
	25398-01	A	BRACKET - Pulley	1	
-84	24327-00		BRACKET - Rudder trim cable pulley, inboard	1	
-85	24328-00		BRACKET - Rudder trim cable pulley, outboard	1	
-86	25343-00	A	PLATE - Fuselage reinforcement, left	1	
	25343-01	A	PLATE - Fuselage reinforcement, right	1	
-87	25554-00	A	PLATE ASSEMBLY - Cockpit rear panel attachment, left	1	
	25564-00	A	PLATE ASSEMBLY - Cockpit rear panel attachment, right	1	
-88	25788-03		SHELF ASSEMBLY - Radio support	1	
-89	27561-00	C	SHIM - Fin spar attachment	1	

A - Used on PA-30 with serial numbers 30-853, 30-902 and up, and PA-39 with serial numbers 39-1 and up.  
 B - Used on PA-30 with serial numbers 30-2 to 30-852 inclusive, 30-854 to 30-901 inclusive.  
 C - Used on PA-30 with serial numbers 30-2 to 30-2000 inclusive, and PA-39 with serial numbers 39-2 to 39-155 inclusive if fin attachment bracket installation kit 760 783 has been installed per Service Letter 679.

When ordering, always specify Part Number, Description and Serial Number of Aircraft

**102**  
INTENTIONALLY LEFT BLANK

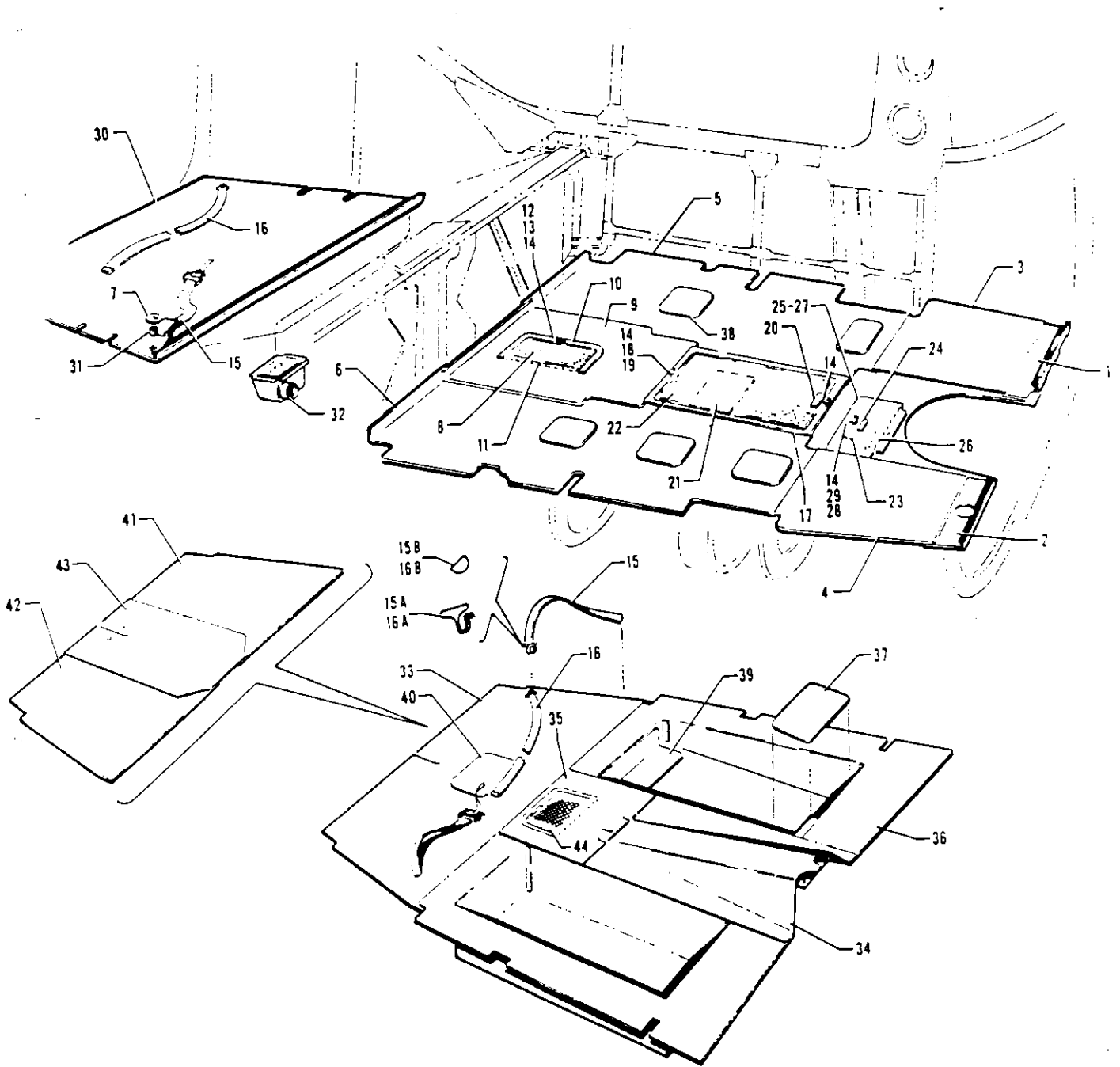

Figure 13. Floorboard Installation



Figure and Index Number	Part Number	Code	NOMENCLATURE	No. Req.	SERIAL NUMBERS AFFECTED
13-	23680 25494 26450	B G A	DRAWING - Fuselage Assembly DRAWING - Fuselage Assembly DRAWING - Fuselage Assembly		
-1	23748-00		FLOORBOARD ASSEMBLY - Front, LH	1	
-2	21558-00	H	FLOORBOARD ASSEMBLY - Front, RH	1	
	21558-04	A	FLOORBOARD ASSEMBLY - Front, RH	1	
-3	24103-00		PLATE ASSEMBLY - Floorboard, LH	1	
-4	24103-01		PLATE ASSEMBLY - Floorboard, RH	1	
-5	24104-00	H	FLOORBOARD ASSEMBLY - Outboard, LH	1	
	24104-04	A	FLOORBOARD ASSEMBLY - Outboard, LH	1	
-6	24106-00		FLOORBOARD ASSEMBLY - Outboard, RH	1	
-7	80122-07		WASHER	2	
-8	23763-02	Y	CARPET ASSEMBLY - Red	1	30-2 to 30-101 inclusive
	23763-03	Y	CARPET ASSEMBLY - Blue	1	30-2 to 30-132 inclusive
	23763-04	Y	CARPET ASSEMBLY - Brown	1	30-2 to 30-106 inclusive
	23763-11	C	CARPET ASSEMBLY - Red	1	
	23763-12	D	CARPET ASSEMBLY - Blue	1	
	23763-13	E	CARPET ASSEMBLY - Brown	1	
	25491-02	F	CARPET ASSEMBLY - Red	1	
	25491-04	F	CARPET ASSEMBLY - Blue	1	
	25491-06	F	CARPET ASSEMBLY - Brown	1	
	25491-08	F	CARPET ASSEMBLY - Gold	1	
	25491-18	F	CARPET ASSEMBLY - Black	1	
-9	23773-00		FLOORBOARD ASSEMBLY - Center	1	
-10	23771-00		DOOR ASSEMBLY - Fuel selector valve access	1	
-11	23771-03		HINGE	1	
-12	494 060		WASHER	1	
-13	487 668		STUD	1	
-14	484 342		CAMLOC RECEPTACLE	4	
-15	17870-08	B	STRAP ASSEMBLY - Baggage tie down, RH (buckle end)	1	
	25543-00	F	STRAP ASSEMBLY - Baggage tie down, RH (buckle end)	1	
-15a	25379-00	F	LINK - Baggage tie down attachment	1	
-15b	25380-00	F	LATCH - Baggage tie down attachment	1	

A - Used on PA-30 with serial numbers 30-1717, 30-1745 and up, and PA-39 with serial numbers 39-1 and up.  
 B - Used on PA-30 with serial numbers 30-2 to 30-852 inclusive, and 30-854 to 30-901 inclusive.  
 C - Used on PA-30 with serial numbers 30-102 to 30-852 inclusive, and 30-854 to 30-901 inclusive.  
 D - Used on PA-30 with serial numbers 30-133 to 30-852 inclusive, and 30-854 to 30-901 inclusive.  
 E - Used on PA-30 with serial numbers 30-107 to 30-852 inclusive, and 30-854 to 30-901 inclusive.  
 F - Used on PA-30 with serial numbers 30-853, 30-902 and up, and PA-39 with serial numbers 39-1 and up.  
 G - Used on PA-30 with serial numbers 30-853, 30-902 to 30-1716 inclusive, 30-1718 to 30-1744 inclusive.  
 H - Used on PA-30 with serial numbers 30-2 to 30-1716 inclusive, 30-1718 to 30-1744 inclusive.  
 Y - Used on PA-30 airplanes only.

When ordering, always specify Part Number, Description and Serial Number of Aircraft



Figure and Index Number	Part Number	Code	NOMENCLATURE	No. Req.	SERIAL NUMBERS AFFECTED
13-16	17871-10		STRAP ASSEMBLY - Baggage tie down, LH (tip end)	1	
	17871-06	H	STRAP ASSEMBLY - Baggage tie down, LH (tip end)	1	
	25544-02	DHK	STRAP ASSEMBLY - Baggage tie down, LH (tip end)	1	
-16a	25379-00	DHK	LINK - Baggage tie down attachment	1	
-16b	25380-00	DHK	LATCH - Baggage tie down attachment	1	
-17	23768-05		DOOR - Landing gear release access	1	
-18	494 060		WASHER	2	
-19	487 668		STUD	2	
-20	21225-00		PLACARD - Emergency gear extension	1	
-21	24143-00	LY	PLACARD - Emergency gear extension	1	30-2 to 30-694 inclusive
	24143-02	LY	PLACARD - Emergency gear extension	1	30-695 to 30-1716 inclusive, 30-1718 to 30-1744 inclusive
	26499-00	G	PLACARD - Emergency gear extension	1	
-22	23767-02	Y	CARPET ASSEMBLY - Red	1	30-2 to 30-101 inclusive
	23767-03	Y	CARPET ASSEMBLY - Blue	1	30-2 to 30-132 inclusive
	23767-04	Y	CARPET ASSEMBLY - Brown	1	30-2 to 30-106 inclusive
	23767-11	E	CARPET ASSEMBLY - Red	1	
	23767-12	A	CARPET ASSEMBLY - Blue	1	
	23767-13	B	CARPET ASSEMBLY - Brown	1	
	25493-02	F	CARPET ASSEMBLY - Red	1	
	25493-04		CARPET ASSEMBLY - Blue	1	
	25493-06	F	CARPET ASSEMBLY - Brown	1	
	25493-08		CARPET ASSEMBLY - Gold	1	
	25493-10		CARPET ASSEMBLY - Black	1	
-23	23821-02	Y	CARPET ASSEMBLY - Red	1	30-2 to 30-101 inclusive
	23821-03	Y	CARPET ASSEMBLY - Blue	1	30-2 to 30-132 inclusive
	23821-04	Y	CARPET ASSEMBLY - Brown	1	30-2 to 30-106 inclusive
	23821-11	C	CARPET ASSEMBLY - Red	1	
	23821-12	A	CARPET ASSEMBLY - Blue	1	
	23821-13	B	CARPET ASSEMBLY - Brown	1	
	25491-10	F	CARPET ASSEMBLY - Red	1	

A - Used on PA-30 with serial numbers 30-133 to 30-852 inclusive, 30-854 to 30-901 inclusive.  
 B - Used on PA-30 with serial numbers 30-107 to 30-852 inclusive, 30-854 to 30-901 inclusive.  
 C - Used on PA-30 with serial numbers 30-102 to 30-852 inclusive, 30-854 to 30-901 inclusive.  
 D - Optional equipment.  
 E - Used on PA-30 with serial numbers 30-102 to 30-852 inclusive, 30-854 to 30-901 inclusive, 30-1717, 30-1745 and up, and PA-39 with serial numbers 39-1 and up.  
 F - Used on PA-30 with serial numbers 30-853, 30-902 to 30-1716 inclusive, 30-1718 to 30-1744 inclusive.  
 G - Used on PA-30 with serial numbers 30-1717, 30-1745 and up, and PA-39 with serial numbers 39-1 and up.  
 H - Used on PA-30 with serial numbers 30-853, 30-902 and up, and PA-39 with serial numbers 39-1 and up.  
 J - Used on PA-30 with serial numbers 30-2 to 30-852 inclusive, 30-854 to 30-901 inclusive.  
 K - Used when fifth and sixth seats are installed.  
 L - Order part no. 26499-00 if Landing Gear Emergency Extension Security Installation Kit 760 627 has been installed per Service Spares Letter SP-325.  
 Y - Used on PA-30 airplanes only.

When ordering, always specify Part Number, Description and Serial Number of Aircraft



Figure and Index Number	Part Number	Code	NOMENCLATURE	No. Req.	SERIAL NUMBERS AFFECTED
13-23	25491-12	D	CARPET ASSEMBLY - Blue	1	
	25491-14	B	CARPET ASSEMBLY - Brown	1	
	25491-16	D	CARPET ASSEMBLY - Gold	1	
	25491-20	D	CARPET ASSEMBLY - Black	1	
	25491-32	H	CARPET ASSEMBLY - Red	1	
-24	24116-00	A	PLACARD - Fuselage door panel	1	
	26657-00	C	PLACARD - Fuselage door panel	1	
-25	23597-00		DOOR ASSEMBLY - Circuit breaker access (without light socket)	1	
	23597-06	A	DOOR ASSEMBLY - Circuit breaker access (with light socket)	1	
-26	23597-03		HINGE ASSEMBLY	1	
-27	23597-02		DOOR	1	
-28	494 060		WASHER	1	
-29	487 668	E	STUD - (26S13-A13)	1	
	487 747	F	STUD - (2600-10)	1	
-30	20524-07	Y	FLOORBOARD ASSEMBLY - Baggage compartment	1	30-2 to 30-589 inclusive
	24817-00	Y	FLOORBOARD ASSEMBLY - Baggage compartment	1	30-590 to 30-852 inclusive, 30-854 to 30-901 inclusive
-31	14175-45		BUSHING	2	
-32	24812-00	Y	TAKE-OFF ASSEMBLY - Cabin air exhaust	1	30-590 to 30-852 inclusive, 30-854 to 30-901 inclusive
-33	25403-00	Y	FLOORBOARD ASSEMBLY - Rear	1	30-853, 30-902 to 30-1188
-34	25373-02	D	FLOORBOARD - Center, rear	1	
-35	25373-03	Y	FLOORBOARD ASSEMBLY - Center, rear	1	30-853, 30-902 to 30-1552
	26119-00	YZ	FLOORBOARD ASSEMBLY - Center, rear	1	30-1553 and up, 39-1 and
-36	25378-00	D	FLOORBOARD ASSEMBLY - Rear, LH	1	
	26147-00	D	FLOORBOARD ASSEMBLY - Rear, RH	1	
-37	25605-00	D	PLATE - Access	1	
-38	22628-00		PLATE - Access	6	
-39	25604-00	D	PLATE - Access	1	
-40	25692-00	Y	PLATE - Access	1	30-853, 30-902 to 30-1188
-41	25742-00	YZ	FLOORBOARD ASSEMBLY - Rear, left	1	30-1189 and up, 39-1 and up
-42	25740-00	YZ	FLOORBOARD ASSEMBLY - Rear, right	1	30-1189 and up, 39-1 and up
-43	25741-00	YZ	FLOORBOARD ASSEMBLY - Rear, center	1	30-1189 and up, 39-1 and up

A - Used on PA-30 with serial numbers 30-2 to 30-1716 inclusive, 30-1718 to 30-1744 inclusive.  
 B - Used on PA-30 with serial numbers 30-853, 30-902 to 30-1716 inclusive, 30-1718 to 30-1744 inclusive.  
 C - Used on PA-30 with serial numbers 30-1717, 30-1745 and up, and PA-39 with serial numbers 39-1 and up.  
 D - Used on PA-30 with serial numbers 30-853, 30-902 and up, and PA-39 with serial numbers 39-1 and up.  
 E - Used on PA-30 with serial numbers 30-2 to 30-1716 inclusive, 30-1718 to 30-1744 inclusive, and PA-39 with serial numbers 39-128 and up.  
 F - Used on PA-30 with serial numbers 30-1717, 30-1745 and up, and PA-39 with serial numbers 39-1 to 39-127 inclusive.  
 H - Used on PA-30 with serial numbers 30-1717, 30-1745 and up, and PA-39 with serial numbers 39-1 and up.  
 Y - Used on PA-30 airplanes only.  
 Z - Used on PA-39 airplanes only.

When ordering, always specify Part Number, Description and Serial Number of Aircraft



Figure and Index Number	Part Number	Code	NOMENCLATURE	No. Req.	SERIAL NUMBERS AFFECTED
13-44	26130-04	AY	DOOR ASSEMBLY - Servo access, red carpet	1	
	26130-05	YZ	DOOR ASSEMBLY - Servo access, blue carpet	1	30-1553 and up, 39-1 and up
	26130-06	A	DOOR ASSEMBLY - Servo access, brown carpet	1	
	26130-07	YZ	DOOR ASSEMBLY - Servo access, gold carpet	1	30-1553 and up, 39-1 and up
	26130-08	YZ	DOOR ASSEMBLY - Servo access, black carpet	1	30-1553 and up, 39-1 and up
	26130-09	B	DOOR ASSEMBLY - Servo access, red carpet	1	
<p>A - Used on PA-30 with serial numbers 30-1553 to 30-1716 inclusive, 30-1718 to 30-1744 inclusive.                      B - Used on PA-30 with serial numbers 30-1717, 30-1745 and up, and PA-39 with serial numbers 39-1 and up.                      Y - Used on PA-30 airplanes only.                      Z - Used on PA-39 airplanes only.</p>					

When ordering, always specify Part Number, Description and Serial Number of Aircraft

ADDED: FEBRUARY 1977

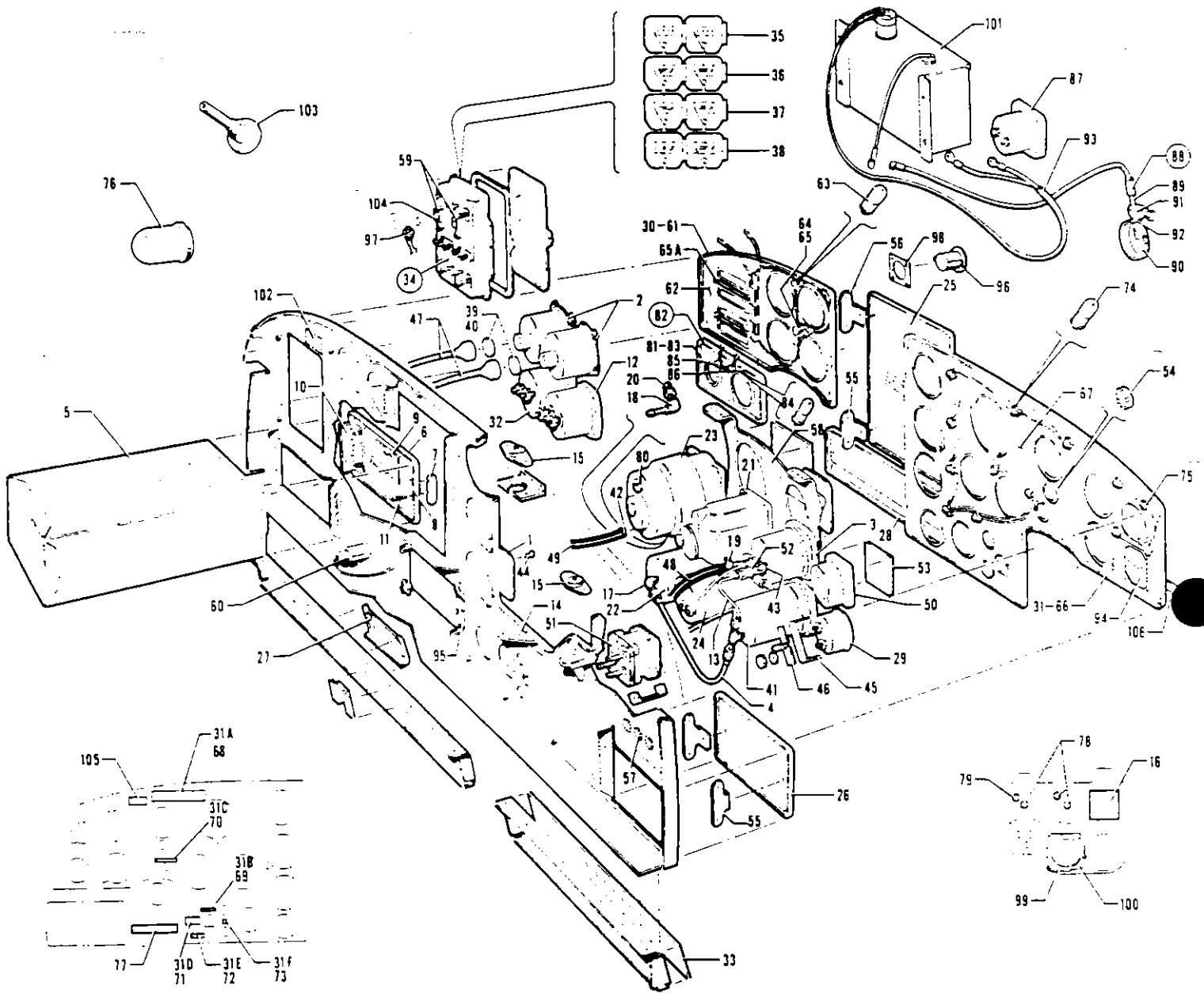

Figure 14. Instrument Panel Installation  
 (PA-30 with Serial Nos. 30-2 to 30-1716 inclusive, 30-1718 to 30-1744 inclusive)



PIPER PARTS CATALOG

Figure and Index Number	Part Number	Code	NOMENCLATURE	No. Req.	SERIAL NUMBERS AFFECTED
14-	23965		DRAWING - Instruments Installation		
	23966		DRAWING - Instruments Installation (Advanced)		
	24230		DRAWING - Glar Ban Lights Installation		
-1	11199-06		COVER - Plate	6	
	11199-07		COVER - Plate	3	
-2	450 646		INSTRUMENT - Tachometer	2	
	25700-02		INSTRUMENT - Dual tachometer (550 704)	1	
-3	30353-20	G	INSTRUMENT - True airspeed indicator	1	
-4	20650-07		LINE ASSEMBLY - Static instrument air	1	
-5	19540-06		COMPARTMENT ASSEMBLY - Glove	1	30-2 to 30-824 inclusive
	19540-09	D	COMPARTMENT ASSEMBLY - Glove	1	30-2 to 30-824 inclusive
-6	19543-02		DOOR ASSEMBLY - Glove compartment	1	30-2 to 30-824 inclusive
-7	20590-00		* HANDLE	1	30-2 to 30-824 inclusive
-8	20599-00		* PLATE	1	30-2 to 30-824 inclusive
-9	19541-02		* DOOR	1	30-2 to 30-824 inclusive
-10	19542-02		* HINGE ASSEMBLY	1	30-2 to 30-824 inclusive
-11	487 545		* STUD - Ball	1	30-2 to 30-824 inclusive
-12	19697-03		GAUGE ASSEMBLY - Manifold pressure	1	
	19697-06	H	GAUGE ASSEMBLY - Manifold pressure	1	
-13	20650-05		LINE ASSEMBLY - Static instrument air	1	
-14	22055-00		BRACKET ASSEMBLY - Gyro panel mounting	2	
-15	475 126		* MOUNTING	1	
-16	11203-02	C	PLATE ASSEMBLY - Cover	1	
-17	458 893		ELBOW - (AN822-3D)	1	
-18	458 929		ELBOW - (AN842-4D)	1	30-2 to 30-685 inclusive
	458 948		ELBOW - (1K1-4-4) Gyro horizon	1	30-686 to 30-1655 inclusive
-19	458 945		ELBOW - (1K1-4-6) Gyros	2	
	458 946	B	ELBOW - (1K1-2-4) Directional Gyro	1	
-20	453 616		REDUCER - (AN912-1D)	1	30-2 to 30-685 inclusive
-21	550 647	F	INSTRUMENT - Directional Gyro (31699-00)	1	30-2 to 30-1655 inclusive
	755 427	E	INSTRUMENT - Directional gyro, 3 inch	1	
-22	550 684		INSTRUMENT - Rate of climb (0-4000 FT./MIN.)	1	
-23	550 646	F	INSTRUMENT - Gyro horizon (31698-00)	1	30-2 to 30-1655 inclusive
	755 428	E	INSTRUMENT - Gyro horizon, 3 inch	1	
-24	450 788		INSTRUMENT - Turn and bank (R.C. Allen A2475-2)	1	
	550 782		INSTRUMENT - Pictorial turn and bank (Mitchell 52D69)	1	

- A - Used on PA-30 with serial numbers 30-2 to 30-1716 inclusive. 30-1718 to 30-1744 inclusive.
- B - Used when 3 inch gyros are installed.
- C - Used when Omni Coupler is not installed.
- D - Used when Dual Brake has been installed.
- E - Used on PA-30 with serial numbers 30-1656 to 30-1716 inclusive. 30-1718 to 30-1744 inclusive.
- F - No longer available.
- G - Order Airspeed Indicator, Part No. 30353-18 if counter-rotating right engine is installed.
- H - Used on Turbocharged Aircraft.

When ordering, always specify Part Number, Description and Serial Number of Aircraft

PIPER PARTS CATALOG

Figure and Index Number	Part Number	Code	NOMENCLATURE	No. Req.	SERIAL NUMBERS AFFECTED
14-25	22341-00		COVER - Instrument panel cover	1	
-26	22462-02		COVER - Instrument panel cover	1	
-27	23378-00		COVER - Instrument panel cover	1	
-28	23545-00		COVER - Instrument panel cover	1	
-29	23167-00		INDICATOR - Flap position	1	
-30	23607-00	C	COVER - Instrument panel, right	1	
	25547-02		COVER - Instrument panel, right	1	30-853, 30-902 to 30-1400
	25783-02	G	COVER - Instrument panel, right	1	
-31	24206-00		COVER ASSEMBLY - Instrument panel, left	1	30-2 to 30-704 inclusive
	24206-02	F	COVER ASSEMBLY - Instrument panel, left	1	
	25557-02		COVER ASSEMBLY - Instrument panel, left	1	30-853, 30-902 to 30-1400
	25785-02		COVER ASSEMBLY - Instrument panel, left	1	30-1401 to 30-1655 inclusive
	25004-03	B C	COVER ASSEMBLY - Instrument panel, left	1	
	25577-02	B	COVER ASSEMBLY - Instrument panel, left	1	30-853, 30-902 to 30-1400
	25796-02	B.G	COVER ASSEMBLY - Instrument panel, left	1	
-31a	27198-00		* PLACARD - Operating practices recommended by the manufacturer	1	
	27130-00	J	* PLACARD - Operating practices recommended by the manufacturer	1	
-31b	24934-00	H	* PLACARD - Gear up	1	
-31c	24936-00	H	* PLACARD - Stall warning	1	
-31d	24939-00	H	* PLACARD - Maximum gear down	1	
-31e	24940-00	H	* PLACARD - Gear down	1	
-31f	24960-00		* PLACARD - Off position	1	30-594 to 30-704 inclusive
-32	24536-00	D	GAUGE ASSEMBLY - Fuel flow	1	
-33	23968-00		PLACARD - Instrument panel	1	
-34	764 431		INSTRUMENT CLUSTER REPLACEMENT KIT	1	
-35	755 499	K	* INSTRUMENT - Fuel quantity	2	
-36	765 003	K	* INSTRUMENT - Oil pressure	2	
-37	765 005	K	* INSTRUMENT - Oil temperature	2	
-38	765 006	K	* INSTRUMENT - Cylinder head temperature	2	
-39	80122-81		WASHER	2	
-40	80122-83		WASHER	AR	
-41	32281-03		INSTRUMENT - Altimeter, sensitive (scale in inches of mercury)	1	
	32281-04	E	INSTRUMENT - Altimeter, sensitive (scale in millibars)	1	

- A - Used on PA-30 with serial numbers 30-2 to 30-1716 inclusive. 30-1718 to 30-1744 inclusive.
- B - Used when 3 inch gyros are installed.
- C - Used on PA-30 with serial numbers 30-2 to 30-852 inclusive. 30-854 to 30-901 inclusive.
- D - Not used when Turbocharger is installed. Refer to RaJay Corporation Parts Catalog.
- E - Optional equipment.
- F - Used on PA-30 with serial numbers 30-705 to 30-852 inclusive. 30-854 to 30-901 inclusive.
- G - Used on PA-30 with serial numbers 30-1401 to 30-1716 inclusive. 30-1718 to 30-1744 inclusive.
- H - Used on PA-30 with serial numbers 30-594 to 30-1716 inclusive. 30-1718 to 30-1744 inclusive.
- J - Used on PA-30 with counter-rotating right engine.
- K - Used with Rochester Gauge Instrument Cluster Assembly only. If A. C. Spark Plug instruments are installed, order Instrument Cluster Replacement Kit 764 431 which contains a new Rochester Gauge Instrument Cluster Assembly complete with all instruments.

When ordering, always specify Part Number, Description and Serial Number of Aircraft

INSTRUMENT PANEL INSTALLATION  
(See Code "A")



SECTION 11  
Fuselage Group

Figure and Index Number	Part Number	Code	NOMENCLATURE	No. Req.	SERIAL NUMBERS AFFECTED
14-42	454 832		CLAMP - Hose #10	2	
-43	451 854		ADAPTER	1	30-2 to 30-335 inclusive
-44	487 394		STUD - Rivet	10	
-45	487 570		STRAP - Mounting	1	
-46	487 350		SEPARATOR - Terminal	1	
-47	486 383		SHAFT ASSEMBLY - Tachometer (146" long)	2	
-48	61541-20		HOSE	1	
-49	61541-21		HOSE	1	
-50	450 689		INSTRUMENT - Clock	1	
-51	550 606		INDICATOR - Suction gauge	1	
-52	488 310		TEE	1	
-53	11203-02		COVER - Plate	2	
-54	17962-04		PLUG BUTTON	1	
-55	22344-00		CLIP - Cover plate	4	
-56	22345-00		CLIP - Cover plate	2	
-57	453 662		PLUG BUTTON - Dull black (BS48137)	3	
-58	22056-00	C	PANEL ASSEMBLY - Gyro insert	1	
	22056-03		PANEL ASSEMBLY - Gyro insert	1	30-853, 30-902 to 30-1655
	24999-00	BC	PANEL ASSEMBLY - Gyro insert	1	
	24999-03	B	PANEL ASSEMBLY - Gyro insert	1	30-853, 30-902 to 30-971
	24999-05	B	PANEL ASSEMBLY - Gyro insert	1	30-972 to 30-1254 inclusive
	25713-00	B	PANEL ASSEMBLY - Gyro insert	1	30-1255 to 30-1655 inclusive
	26320-00	F	PANEL ASSEMBLY - Gyro insert	1	
-59	30234-00		CAPACITOR ASSEMBLY - Instrument cluster	2	
-60	19007-02		LIGHTER ASSEMBLY - Cigar	1	
-61	24216-00	CE	PANEL ASSEMBLY - Instrument panel right cover, Glar Ban	1	
	25566-00	E	PANEL ASSEMBLY - Instrument panel right cover, Glar Ban	1	30-853, 30-902 to 30-1400
	25784-00	EG	PANEL ASSEMBLY - Instrument panel right cover, Glar Ban	1	
-62	24211-00	CE	PANEL	1	
	25547-00	E	PANEL	1	30-853, 30-902 to 30-1400
	25783-00	EG	PANEL	1	
-63	472 037	CE	BULB - Indicator #330	8	
	472 037	DE	BULB - Indicator #330	6	
-64	484 326	CE	RECEPTACLE - (=GB-5952-3-LH-R)	2	
	484 326	DE	RECEPTACLE - (=GB-5952-3-LH-R)	4	
-65	484 327	CE	RECEPTACLE - (=GB-5952-3-RH-R)	6	
	484 327	DE	RECEPTACLE - (=GB-5952-3-RH-R)	2	
-65a	25021-00	DE	BOARD ASSEMBLY - Circuit, 3 lamp	2	

- A - Used on PA-30 with serial numbers 30-2 to 30-1716 inclusive, 30-1718 to 30-1744 inclusive.
- B - Used when 3 inch gyros are installed.
- C - Used on PA-30 with serial numbers 30-2 to 30-852 inclusive, 30-854 to 30-901 inclusive.
- D - Used on PA-30 with serial numbers 30-853, 30-902 to 30-1716 inclusive, 30-1718 to 30-1744 inclusive.
- E - Used when optional Glar Ban Lights are installed.
- F - Used on PA-30 with serial numbers 30-1656 to 30-1716 inclusive, 30-1718 to 30-1744 inclusive.
- G - Used on PA-30 with serial numbers 30-1401 to 30-1716 inclusive, 30-1718 to 30-1744 inclusive.

When ordering, always specify Part Number, Description and Serial Number of Aircraft



Figure and Index Number	Part Number	Code	NOMENCLATURE	No Req	SERIAL NUMBERS AFFECTED
14-00	24217-00	E	PANEL ASSEMBLY - Instrument panel left cover, Glar Ban	1	30-2 to 30-704 inclusive
	24217-03	DE	PANEL ASSEMBLY - Instrument panel left cover, Glar Ban	1	
	25575-00	E	PANEL ASSEMBLY - Instrument panel left cover, Glar Ban	1	30-853, 30-902 to 30-1400
	25786-00	E	PANEL ASSEMBLY - Instrument panel left cover, Glar Ban	1	30-1401 to 30-1655 inclusive
	24217-04	BCE	PANEL ASSEMBLY - Instrument panel left cover, Glar Ban	1	
	25575-02	BE	PANEL ASSEMBLY - Instrument panel left cover, Glar Ban	1	30-853, 30-902 to 30-1400
-67	24212-00	E	PANEL	1	30-2 to 30-704 inclusive
	24212-03	DE	PANEL	1	
	25557-03	E	PANEL	1	30-853, 30-902 to 30-1400
	25785-03	EG	PANEL	1	
	24992-03	BCE	PANEL	1	
	25577-03	BE	PANEL	1	30-853, 30-902 to 30-1400
-68	25796-03	EG	PANEL	1	
	27198-00		PLACARD - Operating practices recommended by the manufacturer	1	
	27130-00	K	PLACARD - Operating practices recommended by the manufacturer	1	
-69	24934-00	J	PLACARD - Gear up	1	
-70	24936-00	J	PLACARD - Stall warning	1	
-71	24939-00	J	PLACARD - Maximum gear down	1	
-72	24940-00	J	PLACARD - Gear down	1	
-73	24960-00		PLACARD - Off position	1	30-594 to 30-704 inclusive
-74	472 037	E	BULB - Indicator (#330)	13	
-75	484 326	CE	RECEPTACLE - (=GB-5952-3-LH-R)	13	
	484 328	EH	RECEPTACLE - (=GB-5952-3-LH-R)	4	
	484 327	EH	RECEPTACLE - (=GB-5952-3-RH-R)	9	
	450 739		COMPASS	1	
-77	24941-00	J	PLACARD - Parking brake	1	
-78	451 939		ADAPTER - (1K10-4-o)	3	
-79	558 913	B	ELBOW - (1K9-4-o) Directional gyro	1	
-80	24712-00		PLUG - Special, gyros (561 064)	3	30-2 to 30-1655 inclusive
	24712-02	BF	PLUG - Special, gyro horizon (561 212)	1	
<p>A - Used on PA-30 with serial numbers 30-2 to 30-1716 inclusive. 30-1718 to 30-1744 inclusive.</p> <p>B - Used when 3 inch gyros are installed.</p> <p>C - Used on PA-30 with serial numbers 30-2 to 30-852 inclusive. 30-854 to 30-901 inclusive.</p> <p>D - Used on PA-30 with serial numbers 30-705 to 30-852 inclusive. 30-854 to 30-901 inclusive.</p> <p>E - Used when optional Glar Ban lights are installed.</p> <p>F - Used on PA-30 with serial numbers 30-1656 to 30-1716 inclusive, 30-1718 to 30-1744 inclusive.</p> <p>G - Used on PA-30 with serial numbers 30-1401 to 30-1716 inclusive, 30-1718 to 30-1744 inclusive.</p> <p>H - Used on PA-30 with serial numbers 30-853, 30-902 to 30-1716 inclusive, 30-1718 to 30-1744 inclusive.</p> <p>J - Used on PA-30 with serial numbers 30-594 to 30-1716 inclusive, 30-1718 to 30-1744 inclusive.</p> <p>K - Used on PA-30 with counter-rotating right engine.</p>					

When ordering, always specify Part Number, Description and Serial Number of Aircraft

PIPER PARTS CATALOG

Figure and Index Number	Part Number	Code	NOMENCLATURE	No. Req.	SERIAL NUMBERS AFFECTED
14-81	25276-00	F	PANEL - Instrument panel cover	1	
-82	25278-00	E,F,G	PANEL ASSEMBLY - Instrument panel cover	1	
-83	25277-00	E,F,G	* PANEL - Instrument panel cover	1	
-84	472 037	E,F,G	* BULB - Indicator (330)	2	
-85	484 326	E,F,G	* RECEPTACLE - (GB-5952-3-LH-R)	1	
-86	484 327	E,F,G	* RECEPTACLE - (GB-5952-3-RH-R)	1	
-87	752 119	B	GAUGE ASSEMBLY - Mixture control indicator	1	
	751 914	C	GAUGE ASSEMBLY - Mixture control indicator	1	
-88	756 907		THERMOCOUPLE ASSEMBLY - (With mounting kit)	2	
-89	756 307		* THERMOCOUPLE - (Less mounting kit)	1	
-90	753 948		* CLAMP - Thermocouple probe attachment	1	
-91	753 949		* CLAMP ASSEMBLY - Thermocouple probe attachment	1	
-92	756 256		* MOUNTING SLEEVE - Thermocouple probe attachment	1	
-93	753 213		WIRE ASSEMBLY - Mixture control gauge	2	
-94	25793-02		PLATE - Cover	1	
-95	25684-00	D	BRACKET - Cover panel attachment	1	
-96	25701-00		METER ASSEMBLY - Hour (550 703)	1	
-97	487 905		SWITCH - Pressure (M-4006-4)	1	
-98	25702-00		PLATE - Hour meter mounting	1	
-99	26272-00		PLATE - Trim (Mitchell turn and bank)	1	
-100	26273-00		PLATE ASSEMBLY - Mounting (Mitchell turn and bank)	1	
-101	751 291		AMPLIFIER ASSEMBLY - Mixture control gauge	1	
-102	31709-00		PLACARD - Icing conditions warning, heated windshield	1	
-103	99479-02	V	GAUGE - Air temperature	1	
-104	484 348		REDUCER - (AN919-OD)	2	
-105	27132-00		PLACARD - Stall and airspeed limitations	1	
	19950-00	H	PLACARD - Stall and airspeed limitations	1	
-106	80379-02		PLACARD - Warning, fuel	1	

- A - Used on PA-30 with serial numbers 30-2 to 30-1716 inclusive. 30-1718 to 30-1744 inclusive.
- B - Used if Mixture Control Gauge Amplifier is not installed. Part is no longer available. Complete Piper Mixture Control Indicator Kit 550 758 may be ordered as a replacement.
- C - Used if Mixture Control Gauge Amplifier is installed.
- D - Used on PA-30 with serial numbers 30-1255 to 30-1716 inclusive. 30-1718 to 30-1744 inclusive.
- E - Used when optional Glar Ban Lights are installed.
- F - Used on PA-30 with serial numbers 30-825 to 30-852 inclusive. 30-854 to 30-901 inclusive.
- G - Used on PA-30 with serial numbers 30-2 to 30-824 inclusive if Kit 756 090 has been installed.
- H - Used on PA-30 with counter-rotating right engine.
- V - These parts must be ordered from Service Spares Department, Piper Aircraft Corporation, Vero Beach, Florida.

When ordering, always specify Part Number, Description and Serial Number of Aircraft

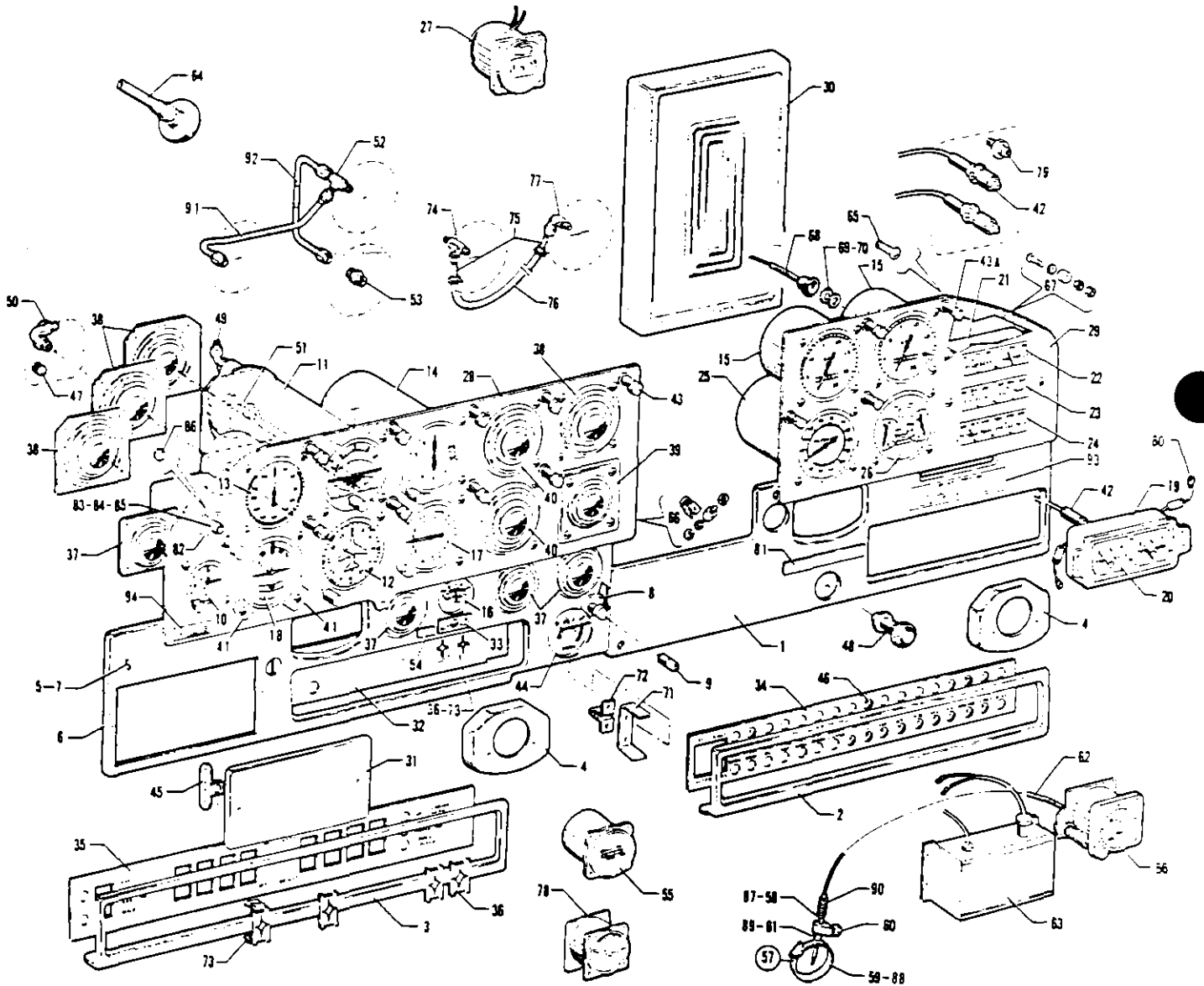

Figure 14A. Instrument Panel Installation  
 (PA-30 with Serial Nos. 30-1717, 30-1745 and up)  
 (PA-39 with Serial Nos. 39-1 and up)

INSTRUMENT PANEL INSTALLATION  
(See Code "A")



SECTION II  
Fuselage Group

Figure and Index Number	Part Number	Code	NOMENCLATURE	No. Req.	SERIAL NUMBERS AFFECTED	
14A-	26703	Y	DRAWING - Instruments Installation		30-1717, 30-1745 to 30-1780 30-1781 and up, 39-1 and up	
	26867	YZ	DRAWING - Instruments Installation			
	26757		DRAWING - Instruments Installation (Advanced)			
	26708	Y	DRAWING - Glar Ban Lights Installation		30-1717, 30-1745 to 30-1780 30-1781 and up, 39-1 and up	
	26871	YZ	DRAWING - Glar Ban Lights Installation			
-1	26398-02		COVER - Instrument panel, right, red	1		
	26398-03		COVER - Instrument panel, right, blue	1		
	26398-04		COVER - Instrument panel, right, black	1		
	26398-05		COVER - Instrument panel, right, beige	1		
	26398-06		COVER - Instrument panel, right, white	1		
	26398-12	C	COVER - Instrument panel, right, red	1		
	26398-13	C	COVER - Instrument panel, right, blue	1		
	26398-14	C	COVER - Instrument panel, right, black	1		
	26398-15	C	COVER - Instrument panel, right, beige	1		
	26398-16	C	COVER - Instrument panel, right, white	1		
	26398-17	B	COVER - Instrument panel, right, red	1		
	26398-18	B	COVER - Instrument panel, right, blue	1		
	26398-19	B	COVER - Instrument panel, right, black	1		
	26398-20	B	COVER - Instrument panel, right, beige	1		
	26398-21	B	COVER - Instrument panel, right, white	1		
	-2	26428-02		COVER - Circuit breaker panel, beige	1	
		26428-03		COVER - Circuit breaker panel, black	1	
		26428-04		COVER - Circuit breaker panel, white	1	
	-3	26511-02		COVER - Switch panel, beige	1	
		26511-03		COVER - Switch panel, black	1	
		26511-04		COVER - Switch panel, white	1	
-4	26523-02		COVER - Control wheel shaft, white	2		
	26523-03		COVER - Control wheel shaft, blue	2		
	26523-04		COVER - Control wheel shaft, red	2		
	26523-05		COVER - Control wheel shaft, beige	2		
	26523-06		COVER - Control wheel shaft, black	2		
-5	26563-05	Y	COVER - Instrument panel, left, red	1	30-1717, 30-1745 to 30-1780	
	26563-11	Y	COVER - Instrument panel, left, blue	1		
	26563-17	Y	COVER - Instrument panel, left, black	1	30-1717, 30-1745 to 30-1780	
	26563-23	Y	COVER - Instrument panel, left, beige	1		
	26563-29	Y	COVER - Instrument panel, left, white	1	30-1717, 30-1745 to 30-1780	
	26820-04	YZ	COVER - Instrument panel, left, red	1		
	26820-08	YZ	COVER - Instrument panel, left, blue	1	30-1781 and up, 39-1 and up	
	26820-12	YZ	COVER - Instrument panel, left, black	1		
	26820-1c	YZ	COVER - Instrument panel, left, beige	1	30-1781 and up, 39-1 and up	
	26820-20	YZ	COVER - Instrument panel, left, white	1		

A - Used on PA-30 with serial numbers 30-1717, 30-1745 and up, and PA-39 with serial numbers 39-1 and up.  
 B - Used when AltiMatic III or AltiMatic IIIB-1 is installed.  
 C - Used when AutoControl III is installed.  
 Y - Used on PA-30 airplanes only.  
 Z - Used on PA-39 airplanes only.

When ordering, always specify Part Number, Description and Serial Number of Aircraft

PIPER PARTS CATALOG

Figure and Index Number	Part Number	Code	NOMENCLATURE	No. Req.	SERIAL NUMBERS AFFECTED	
14A-6	26692-02	B.Y	COVER ASSEMBLY - Instrument panel, Glar Ban, left, red	1	30-1717, 30-1745 to 30-1780	
	26692-04	B.Y	COVER ASSEMBLY - Instrument panel, Glar Ban, left, blue	1	30-1717, 30-1745 to 30-1780	
	26692-06	B.Y	COVER ASSEMBLY - Instrument panel, Glar Ban, left, black	1	30-1717, 30-1745 to 30-1780	
	26692-08	B.Y	COVER ASSEMBLY - Instrument panel, Glar Ban, left, beige	1	30-1717, 30-1745 to 30-1780	
	26692-10	B.Y	COVER ASSEMBLY - Instrument panel, Glar Ban, left, white	1	30-1717, 30-1745 to 30-1780	
	26692-12	B.C	COVER ASSEMBLY - Instrument panel, Glar Ban, left, red	1		
	26692-13	B.C	COVER ASSEMBLY - Instrument panel, Glar Ban, left, blue	1		
	26692-14	B.C	COVER ASSEMBLY - Instrument panel, Glar Ban, left, black	1		
	26692-15	B.C	COVER ASSEMBLY - Instrument panel, Glar Ban, left, beige	1		
	26692-16	B.C	COVER ASSEMBLY - Instrument panel, Glar Ban, left, white	1		
	27035-07	B.Z	COVER ASSEMBLY - Instrument panel, Glar Ban, left, red	1	39-7 and up	
	27035-08	B.Z	COVER ASSEMBLY - Instrument panel, Glar Ban, left, blue	1	39-7 and up	
	27035-09	B.Z	COVER ASSEMBLY - Instrument panel, Glar Ban, left, black	1	39-7 and up	
	27035-10	B.Z	COVER ASSEMBLY - Instrument panel, Glar Ban, left, beige	1	39-7 and up	
	27035-11	B.Z	COVER ASSEMBLY - Instrument panel, Glar Ban, left, white	1	39-7 and up	
	-7	26563-04	B.Y	* COVER - Instrument panel, left, red	1	30-1717, 30-1745 to 30-1780
		26563-10	B.Y	* COVER - Instrument panel, left, blue	1	30-1717, 30-1745 to 30-1780
		26563-16	B.Y	* COVER - Instrument panel, left, black	1	30-1717, 30-1745 to 30-1780
		26563-22	B.Y	* COVER - Instrument panel, left, beige	1	30-1717, 30-1745 to 30-1780
26563-28		B.Y	* COVER - Instrument panel, left, white	1	30-1717, 30-1745 to 30-1780	
26820-05		B.Y.Z	* COVER - Instrument panel, left, red	1	30-1781 and up, 39-1 and up	
26820-09		B.Y.Z	* COVER - Instrument panel, left, blue	1	30-1781 and up, 39-1 and up	
26820-13		B.Y.Z	* COVER - Instrument panel, left, black	1	30-1781 and up, 39-1 and up	
26820-17		B.Y.Z	* COVER - Instrument panel, left, beige	1	30-1781 and up, 39-1 and up	
26820-21		B.Y.Z	* COVER - Instrument panel, left, white	1	30-1781 and up, 39-1 and up	
-8	484 278	B	* RECEPTACLE - ( GB-5952-3RH-CW)	4		
-9	472 054	B	* BULB - Indicator ( 330)	4		
-10	450 706		INSTRUMENT - Clock	1		
-11	755 428		INSTRUMENT - Gyro horizon, 3 inch	1		
-12	755 427		INSTRUMENT - Directional gyro, 3 inch	1		
-13	30353-20	D.Y	INSTRUMENT - True airspeed indicator	1		
	30353-18	Z	INSTRUMENT - True airspeed indicator	1		
-14	32281-03		INSTRUMENT - Altimeter, sensitive (Scale in inches of mercury)	1		
	32281-04		INSTRUMENT - Altimeter, sensitive (Scale in millibars)	1		
-15	450 646		INSTRUMENT - Tachometer assembly (13621-04)	2		
	25700-02		INSTRUMENT - Dual tachometer assembly (550 704)	1		
-16	23857-00		INSTRUMENT - Ammeter	1		
-17	550 684		INSTRUMENT - Rate of climb (0-4000 FT./MIN.)	1		
-18	450 788		INSTRUMENT - Turn and bank (R.C. Allen A2475-2)	1		
	32737-02	Y	INSTRUMENT - Pictorial turn and bank (Mitchell) (550 790)	1		
	32737-04	Z	INSTRUMENT - Pictorial turn and bank (Mitchell) (550 588)	1		
-19	28625-05		CLUSTER ASSEMBLY - Instrument (Rochester Gauge)	1		
-20	755 499	E	* GAUGE ASSEMBLY - Fuel quantity	2		

- A - Used on PA-30 with serial numbers 30-1717, 30-1745 and up, and PA-39 with serial numbers 39-1 and up.
- B - Used when Glar Ban lights are installed.
- C - Used on PA-30 with serial numbers 30-1781 and up, and PA-39 with serial numbers 39-1 to 39-6 inclusive.
- D - Order Part No. 30353-18 if counter-rotating right engine is installed.
- E - Used with Rochester Gauge Instrument Cluster Assembly only. If A. C. Spark Plug instruments are installed, order complete instrument cluster assembly as a replacement.
- Y - Used on PA-30 airplanes only.
- Z - Used on PA-39 airplanes only.

When ordering, always specify Part Number, Description and Serial Number of Aircraft



## PIPER PARTS CATALOG

Figure and Index Number	Part Number	Code	NOMENCLATURE	No. Req.	SERIAL NUMBERS AFFECTED
14A-21	764 432		INSTRUMENT CLUSTER REPLACEMENT KIT	1	
-22	765 003	N	* GAUGE ASSEMBLY - Oil pressure	2	
-23	765 005	N	* GAUGE ASSEMBLY - Oil temperature	2	
-24	765 006	N	* GAUGE ASSEMBLY - Cylinder head temperature	2	
-25	19697-03		GAUGE ASSEMBLY - Manifold pressure	1	
	19697-06	F	GAUGE ASSEMBLY - Manifold pressure	1	
-26	26821-00	G	GAUGE - Dual fuel flow	1	
-27	550 804		COMPASS - (2350 DL4-CMB)	1	
-28	26362-04	Y	PANEL ASSEMBLY - Instrument panel, left	1	30-1717, 30-1745 to 30-1780
	26362-08	D.H.Y	PANEL ASSEMBLY - Instrument panel, left	1	30-1717, 30-1745 to 30-1780
	26362-09	J.Y	PANEL ASSEMBLY - Instrument panel, left	1	30-1717, 30-1745 to 30-1780
	26362-10	E	PANEL ASSEMBLY - Instrument panel, left	1	
	27030-02	Z	PANEL ASSEMBLY - Instrument panel, left	1	39-7 to 39-145 inclusive
	27030-02	L.Z	PANEL ASSEMBLY - Instrument panel, left	1	39-7 to 39-83 inclusive
	27030-03	L.Z	PANEL ASSEMBLY - Instrument panel, left	1	39-84 to 39-145 inclusive
	27288-00	Z	PANEL ASSEMBLY - Instrument panel, left	1	39-146 and up
-29	26469-02		PANEL - Instrument panel, right	1	
	26469-03	B	PANEL - Instrument panel, right	1	
-30	26779-00		PANEL - Instrument panel opening cover	1	
-31	22462-02	Y	PANEL - Instrument panel opening cover	1	30-1717, 30-1745 to 30-1780
-32	26423-00	K	PLACARD - Parking brake and map light	1	
	26422-00	C.K	PLACARD - Parking brake and autopilot selector (AutoControl)	1	
	26418-00	D.K	PLACARD - Parking brake and autopilot selector (AltiMatic)	1	
	26418-02		PLACARD - Parking brake and autopilot selector	1	39-146 and up
-33	26426-00	K.M	PLACARD - Alternator indicator	1	
	27268-00	M.Z	PLACARD - Alternator inoperative	1	39-146 and up

- A - Used on PA-30 with serial numbers 30-1717, 30-1745 and up, and PA-39 with serial numbers 39-1 and up.
- B - Used when Dual Tachometer is installed
- C - Used when AutoControl III and Radio Coupler are installed.
- D - Used when AltiMatic III is installed.
- E - Used on PA-30 with serial numbers 30-1781 and up, and PA-39 with serial numbers 39-1 to 39-6 inclusive.
- F - Used on Turbocharged Aircraft.
- G - Not used when Turbocharger is installed. Refer to RaJay Corporation Parts Catalog.
- H - Used when AutoControl III is installed.
- J - Used when AutoControl III or AltiMatic III with Glar Ban Lights is installed.
- K - Used on PA-30 with serial numbers 30-1717, 30-1745 and up, and PA-39 with serial numbers 39-1 to 39-145 inclusive.
- L - Used when AltiMatic III B is installed.
- M - Order Placard 33438-00 for PA-30 with serial numbers 30-1717, 30-1745 to 30-2000 inclusive, and PA-39 with serial numbers 39-1 to 39-145 inclusive, if Alternator Warning Light Installation Kit 760 744 has been installed.
- N - Used with Rochester Gauge Instrument Cluster Assembly only. If A. C. Spark Plug instruments are installed, order Instrument Cluster Replacement Kit 764 432 which contains a new Rochester Gauge Instrument Cluster Assembly complete with all instruments.
- Y - Used on PA-30 airplanes only.
- Z - Used on PA-39 airplanes only.

When ordering, always specify Part Number, Description and Serial Number of Aircraft

PIPER PARTS CATALOG

Figure and Index Number	Part Number	Code	NOMENCLATURE	No. Req.	SERIAL NUMBERS AFFECTED
14A-34	26534-00	Y	PLACARD - Circuit breaker panel	1	
	27051-00	Z	PLACARD - Circuit breaker panel	1	39-1 to 39-145 inclusive
	27051-03	Z	PLACARD - Circuit breaker panel	1	39-146 and up
-35	26543-00	D	PLACARD - Switch panel	1	
	27265-00	Z	PLACARD - Switch panel	1	39-146 and up
-36	32510-00		PLATE - Cover	7	
-37	41679-00		PLATE - Cover	4	
-38	41678-00		PLATE - Cover	5	
-39	43086-02	Y	PLATE - Cover	1	30-1717, 30-1745 to 30-1780
	41678-00	E	PLATE - Cover	1	
	41679-00	Z	PLATE - Cover	1	39-7 to 39-145 inclusive
	41678-00	Z	PLATE - Cover	1	39-146 and up
-40	41678-00	D	PLATE - Cover	2	
	52798-02	Z	PLATE - Cover	2	39-146 and up
-41	52826-05	Z	COVER - Instrument mounting	1	39-146 and up
-42	26753-00	C	BOLT LITE ASSEMBLY	3	
-43	472 776	C	BOLT LITE - (P-65-3-CW-14)	15	
-43a	757 877		* CAP ASSEMBLY - (Blue lens 5952-2CW)	1	
-44	23167-00		INDICATOR - Flap position	1	
-45	22344-00	Y	CLIP - Cover plate	2	30-1717, 30-1745 to 30-1780
-46	453 655		PLUG - Button (BS51051)	17	
-47	24712-02		PLUG - Directional gyro	1	
-48	472 653		LIGHTER - Cigar (60248)	1	
-49	558 937		ELBOW - Gyro horizon (1K46-1)	1	
-50	558 936		ELBOW - Directional gyro (1K45-1)	1	
-51	451 939		ADAPTER - Gyro horizon (1K10-4-6)	1	
-52	488 310		TEE - Rate of climb (AN826-3D)	1	
-53	476 647		NIPPLE - (AN816-3D)	1	
-54	31709-00		PLACARD - Icing conditions warning, heated windshield	1	
-55	32658-00	B	METER ASSEMBLY - Engine hour	1	
-56	751 914	F	GAUGE ASSEMBLY - Mixture control indicator (Delta)	1	
	32745-02		GAUGE ASSEMBLY - Mixture control indicator (Radair)	1	39-133 and up
-57	756 907	F	THERMOCOUPLE ASSEMBLY - (With mounting kit) (Delta)	2	
-58	756 307	F	* THERMOCOUPLE - (Less mounting kit) (Delta)	1	
-59	753 948	F	* CLAMP - Thermocouple probe attachment (Delta)	1	
-60	753 949	F	* CLAMP ASSEMBLY - Thermocouple probe attachment (Delta)	1	
-61	756 256	F	* MOUNTING SLEEVE - Thermocouple probe attachment (Delta)	1	

- A - Used on PA-30 with serial numbers 30-1717, 30-1745 and up, and PA-39 with serial numbers 39-1 and up.
- B - Used when Dual Tachometer is installed.
- C - Used when Glar Ban Lights are installed.
- D - Used on PA-30 with serial numbers 30-1717, 30-1745 and up, and PA-39 with serial numbers 39-1 to 39-145 inclusive
- E - Used on PA-30 with serial numbers 30-1781 and up, and PA-39 with serial numbers 39-1 to 39-6 inclusive.
- F - Used on PA-30 with serial numbers 30-2 and up, and PA-39 with serial numbers 39-1 to 39-132 inclusive.
- Y - Used on PA-30 airplanes only.
- Z - Used on PA-39 airplanes only.

When ordering, always specify Part Number, Description and Serial Number of Aircraft

**PIPER PARTS CATALOG**

Figure and Index Number	Part Number	Code	NOMENCLATURE	No Req	SERIAL NUMBERS AFFECTED
14A-62	753 213	C	WIRE ASSEMBLY - Mixture control gauge (Delta)	2	
	756 623		WIRE ASSEMBLY - Mixture control gauge (Radair)	2	39-133 and up
-63	751 291	C	AMPLIFIER ASSEMBLY - Mixture control gauge (Delta)	1	
-64	99479-02	V	GAUGE - Air temperature	1	
-65	26870-00		BUTTON - Plug	15	
-66	406 704		NUT - Cap. dull black (22-K1-82)	5	
	42034-00		STRAP - Ground	5	
	475 109		MOUNT - (J-7219-22)	5	
	407 134		WASHER - (AN960-8)	10	
	404 910		NUT - (MS20365-832C)	5	
-67	406 704		NUT - Cap. dull black (22-K1-82)	4	
	404 833		NUT - (MS20364-832C)	4	
	14843-113		BUSHING	4	
	407 134		WASHER - (AN936-A8)	4	
	415 538		SCREW - Machine (MS35206-248)	4	
-68	486 583		SHAFT ASSEMBLY - Tachometer (146" long)	2	
-69	80122-81		WASHER	2	
-70	80122-83		WASHER	AR	
-71	487 726		STRAP - Mounting (6460429)	1	
-72	487 350		SEPARATOR - Terminal (1515642)	1	
-73	453 424		BRACKET - Narrow snap in "F"	7	
-74	488 310		TEE - Dual altimeter (AN826-3D)	1	
-75	17881-04		LINE ASSEMBLY - Dual altimeter	2	
-76	83161-17		HOSE - Dual altimeter	1	
-77	458 893		ELBOW - Dual altimeter (AN822-3D)	1	
-78	550 606		INDICATOR - Suction gauge	1	
-79	484 346		REDUCER - (AN919-OD)	2	
-80	30234-00		CAPACITOR ASSEMBLY - Instrument cluster, right	1	
	30234-03		CAPACITOR ASSEMBLY - Instrument cluster, left	1	
-81	27198-00	Y	PLACARD - Operating practices recommended by the manufacturer	1	
	27130-00	B,Z	PLACARD - Operating practices recommended by the manufacturer	1	
-82	27178-00	Z	PLACARD - Pitch out of trim (581 681)	1	39-84 and up
-83	472 816	Z	LIGHT - Trim warning (800-1030-0333-504)	1	39-84 and up
-84	757 938	Z	* CAP ASSEMBLY - (800-0333-500)	1	39-84 and up
-85	472 037	Z	LAMP - (14V. 330)	1	39-84 and up
-86	453 865	Z	BUTTON - Plug (SS51338)	1	39-84 and up
-87	756 337		THERMOCOUPLE - Mixture control (Radair)	2	39-133 and up
-88	757 866		CLAMP - Mixture control (Radair)	2	39-133 and up
-89	751 294		ADAPTER ASSEMBLY - Mixture control (Radair)	2	39-133 and up
-90	756 273		SPACER - (Large) Mixture control (Radair)	22	39-133 and up
	756 274		SPACER - (Small) Mixture control (Radair)	22	39-133 and up
-91	26577-00		LINE ASSEMBLY - Static instrument air	1	
-92	26549-00		LINE ASSEMBLY - Static instrument air, rate of climb	1	
-93	27196-00	B	PLACARD - Operation (United Kingdom)	1	
-94	80379-02		PLACARD - Warning, fuel	1	

A - Used on PA-30 with serial numbers 30-1717, 30-1745 and up, and PA-39 with serial numbers 39-1 and up.  
 B - Used on PA-30 with counter-rotating right engine.  
 C - Used on PA-30 with serial numbers 30-2 and up, and PA-39 with serial numbers 39-1 to 39-132 inclusive.  
 V - These parts must be ordered from Service Spares Department, Piper Aircraft Corporation, Vero Beach, Florida.  
 Y - Used on PA-30 airplanes only.  
 Z - Used on PA-39 airplanes only.

When ordering, always specify Part Number, Description and Serial Number of Aircraft

**1 D20**  
INTENTIONALLY LEFT BLANK

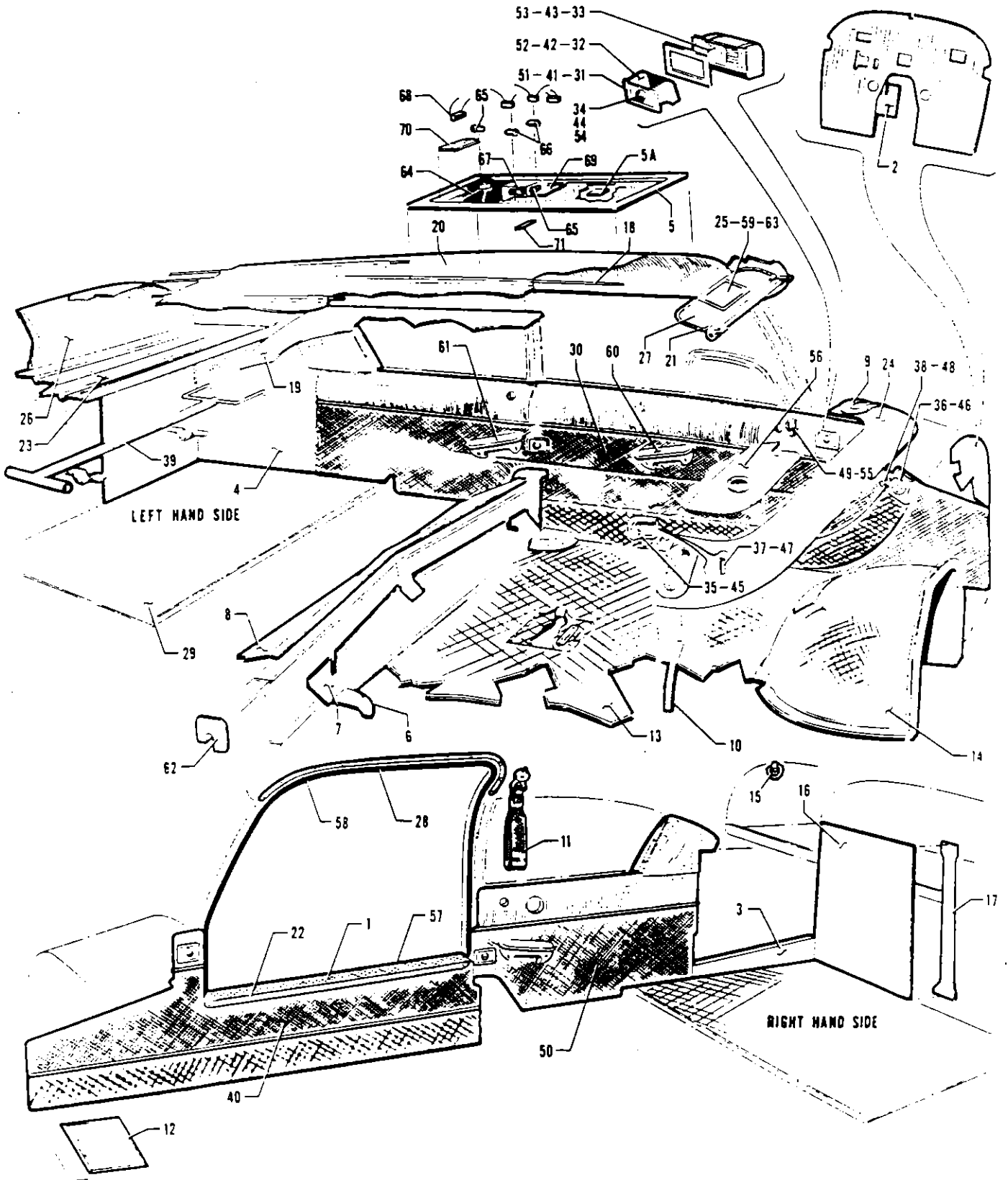

Figure 15. Cockpit Finishing Installation  
(PA-30 with Serial Nos. 30-2 to 30-852, 30-854 to 30-901 inclusive)

COCKPIT FINISHING INSTALLATION  
(See Code "A")



SECTION II  
Fuselage Group

Figure and Index Number	Part Number	Code	NOMENCLATURE	No. Req.	SERIAL NUMBERS AFFECTED
15-	23903		DRAWING - Finishing Installation Cockpit		
-1	20512-00		SILL - Door	1	
-2	20523-00		PLATE - Cable guard	1	
-3	20537-00		PANEL - Baggage compartment, RH	1	
-4	20575-00		PANEL - Baggage compartment, LH	1	
-5	24705-00		PANEL - Cabin light	1	
-5a	24945-00		PLACARD - Nose position	1	30-594 and up
-6	21007-00		PLATE - Fuel line cover, LH	1	
	21007-01		PLATE - Fuel line cover, RH	1	
-7	22340-03		PLATE ASSEMBLY - Front floor shield	1	
-8	23922-00		SKIRT ASSEMBLY - Rear floor	1	
-9	21336-00		PLATE - Instrument panel handhold	2	
-10	21373-00		STRIP - Cowl cover attachment, LH	1	
	21373-01		STRIP - Cowl cover attachment, RH	1	
-11	19927-02		LOOP ASSEMBLY - Assist, charcoal	1	
	19927-03		LOOP ASSEMBLY - Assist, brown	1	
-12	21525-02		PLATE - Heel, LH	1	
	21525-03		PLATE - Heel, RH	1	
-13	23864-02		CARPET - Floor, red	1	30-2 to 30-101 inclusive
	23864-03		CARPET - Floor, blue	1	30-2 to 30-132 inclusive
	23864-04		CARPET - Floor, brown	1	30-2 to 30-106 inclusive
	23864-11		CARPET - Floor, red	1	30-102 and up
	23864-12		CARPET - Floor, blue	1	30-133 and up
	23864-13		CARPET - Floor, brown	1	30-107 and up
-14	24075-02		CARPET - Nose wheel cover, red	1	30-2 to 30-101 inclusive
	24075-03		CARPET - Nose wheel cover, blue	1	30-2 to 30-132 inclusive
	24075-04		CARPET - Nose wheel cover, brown	1	30-2 to 30-106 inclusive
	24075-23		CARPET - Nose wheel cover, red	1	30-102 and up
	24075-24		CARPET - Nose wheel cover, blue	1	30-133 and up
	24075-25		CARPET - Nose wheel cover, brown	1	30-107 and up
-15	487 629		HANGER - Coat	1	
-16	21639-18		PANEL - Baggage compartment, rear, LH	1	
	21639-19		PANEL - Baggage compartment, rear, RH	1	
-17	21639-20		CHANNEL - Baggage compartment	1	
-18	23320-02		ROD - Threaded, 77-3/4"	1	
	23320-05		ROD - Threaded, 52.75"	1	
	23320-04		ROD - Threaded, 50-1/2"	2	
-19	23321-00		PLATE - Headlining support	1	
-20	23298-10	B	HEADLINING ASSEMBLY - Gray	1	
	23298-11	B	HEADLINING ASSEMBLY - Sand	1	
	23298-29		HEADLINING ASSEMBLY - Gray and white	1	30-491, 30-514 and up
	23298-32		HEADLINING ASSEMBLY - Sand and white	1	30-491, 30-514 and up
-21	21824-00		SUPPORT - Sun visor	4	
-22	24173-00		STRIP - Side panel retaining	1	
-23	22123-03		SHELF ASSEMBLY - Hat	1	
-24	22454-00		COVER - Cowl, black	1	
-25	25219-00		PLACARD - Alternate static source instruction	1	

A - Used on PA-30 with serial numbers 30-2 to 30-852 inclusive, 30-854 to 30-901 inclusive.

B - Used on PA-30 with serial numbers 30-2 to 30-490, 30-492 to 30-513 inclusive.

When ordering, always specify Part Number, Description and Serial Number of Aircraft

SECTION II  
Fuselage Group



COCKPIT FINISHING INSTALLATION  
(See Code "A")

Figure and Index Number	Part Number	Code	NOMENCLATURE	No. Req.	SERIAL NUMBERS AFFECTED
15-26	23398-00		PANEL ASSEMBLY - Hat shelf, rear, gray	1	30-2 to 30-681 inclusive
	23398-02		PANEL ASSEMBLY - Hat shelf, rear, sand	1	30-2 to 30-681 inclusive
	24893-03		PANEL ASSEMBLY - Hat shelf, rear, gray	1	30-682 and up
	24893-04		PANEL ASSEMBLY - Hat shelf, rear, sand	1	30-682 and up
-27	23040-08		VISOR ASSEMBLY - Gray	2	
	23040-09		VISOR ASSEMBLY - Sand	2	
-28	23269-03	B	TRIM STRIP ASSEMBLY - Door	1	
-29	23569-00		CARPET - Baggage compartment, black	1	30-2 to 30-589 inclusive
	23569-02		CARPET - Baggage compartment, black	1	30-590 and up
-30	23276-16		PANEL ASSEMBLY - Cockpit left side complete, sand	1	
	23276-18	C	PANEL ASSEMBLY - Cockpit left side complete	1	
-31	13950-00		PANEL - Ash box	2	
-32	453 141		ASH BOX	2	
-33	484 385		RETAINER - Ash box	2	
-34	471 075		KNOB - White	2	
-35	22289-00		OUTLET - Cabin heat	1	
-36	22334-00		VALVE - Cabin hot air outlet	1	
-37	22448-00		CLIP - Carpet retaining	1	
-38	471 077		KNOB - Black	1	
-39	18994-00		TOW BAR	1	
-40	23277-12		PANEL ASSEMBLY - Right front cockpit complete, sand	1	
	23277-19	C	PANEL ASSEMBLY - Right front cockpit complete	1	
-41	13950-00		PANEL - Ash box	1	
-42	453 141		ASH BOX	1	
-43	484 385		RETAINER - Ash box	1	
-44	471 075		KNOB - White	1	
-45	22289-00		OUTLET - Cabin heat	1	
-46	22334-00		VALVE - Cabin hot air outlet	1	
-47	22448-00		CLIP - Carpet retaining	1	
-48	471 077		KNOB - Black	1	
-49	23302-00		WASHER - Microphone retaining	1	
-50	23278-05		PANEL ASSEMBLY - Cockpit, rear right side complete, sand	1	
	23278-12	C	PANEL ASSEMBLY - Cockpit, rear right side complete	1	
-51	13950-00		PANEL - Ash box	1	
-52	453 141		ASH BOX	1	
-53	484 385		RETAINER - Ash box	1	
-54	471 075		KNOB - White	1	
-55	23303-00		HOLDER - Microphone (used with telephonics mike RS-38A)	1	
	453 415		BRACKET - Microphone (used with telex mike 66C)	1	
-56	22452-00		PANEL ASSEMBLY - Instrument access	1	
-57	23305-11		STRIP ASSEMBLY - Weather, tan (cloth)	1	30-2 to 30-101 inclusive
	25156-02		STRIP ASSEMBLY - Weather, tan (vinyl)	1	30-102 and up
	23305-34		STRIP ASSEMBLY - Weather, red (leather)	1	30-2 to 30-101 inclusive
	23305-36		STRIP ASSEMBLY - Weather, blue (leather)	1	30-2 to 30-101 inclusive
	23305-42		STRIP ASSEMBLY - Weather, red (vinyl)	1	30-102 and up
	23305-44		STRIP ASSEMBLY - Weather, blue (vinyl)	1	30-102 and up

A - Used on PA-30 with serial numbers 30-2 to 30-852 inclusive, 30-854 to 30-901 inclusive.  
 B - When ordering, specify color gray or sand.  
 C - When ordering, specify color red or blue.

When ordering, always specify Part Number, Description and Serial Number of Aircraft



Figure and Index Number	Part Number	Code	NOMENCLATURE	No. Req	SERIAL NUMBERS AFFECTED
15-58	23305-18		STRIP ASSEMBLY - Weather, tan (cloth)	1	30-2 to 30-101 inclusive
	25156-04		STRIP ASSEMBLY - Weather, tan (vinyl)	1	30-102 and up
	23305-35		STRIP ASSEMBLY - Weather, red (leather)	1	30-2 to 30-101 inclusive
	23305-37		STRIP ASSEMBLY - Weather, blue (leather)	1	30-2 to 30-101 inclusive
	23305-43		STRIP ASSEMBLY - Weather, red (vinyl)	1	30-102 and up
	23305-45		STRIP ASSEMBLY - Weather, blue (vinyl)	1	30-102 and up
-59	31109-00		PLACARD - Engine starting instructions (envelope type)	1	30-2 to 30-593 inclusive
	31391-00		PLACARD - Engine starting instructions	1	30-594 and up
	24849-00		PLACARD - Check list	1	30-594 and up
-60	23463-16		ARMREST ASSEMBLY - Front, sand	1	
	23463-17		ARMREST ASSEMBLY - Front, red	1	
	23463-18		ARMREST ASSEMBLY - Front, blue	1	
-61	23463-16		ARMREST ASSEMBLY - Rear, sand	2	30-2 to 30-589 inclusive
	23463-17		ARMREST ASSEMBLY - Rear, red	2	30-2 to 30-589 inclusive
	23463-18		ARMREST ASSEMBLY - Rear, blue	2	30-2 to 30-589 inclusive
	24953-00		ARMREST ASSEMBLY - Left, rear, red	1	30-590 and up
	24953-01		ARMREST ASSEMBLY - Right, rear, red	1	30-590 and up
	24953-02		ARMREST ASSEMBLY - Left, rear, blue	1	30-590 and up
	24953-05		ARMREST ASSEMBLY - Right, rear, blue	1	30-590 and up
	24953-08		ARMREST ASSEMBLY - Left, rear, sand	1	30-590 and up
	24953-09		ARMREST ASSEMBLY - Right, rear, sand	1	30-590 and up
-62	24967-00		COVER ASSEMBLY - Spar fitting, left, red	1	
	24967-01		COVER ASSEMBLY - Spar fitting, right, red	1	
	24967-05		COVER ASSEMBLY - Spar fitting, left, blue	1	
	24967-08		COVER ASSEMBLY - Spar fitting, right, blue	1	
	24967-18		COVER ASSEMBLY - Spar fitting, left, sand	1	
	24967-19		COVER ASSEMBLY - Spar fitting, right, sand	1	
-63	24935-00		SLEEVE ASSEMBLY - Sun visor placard	2	30-594 and up
-64	21879-00		SPEAKER ASSEMBLY	1	
-65	472 036		LAMP - (=89)	2	
-66	472 026		LAMP - (=90)	2	
-67	472 038		LAMP - (=93)	1	
-68	487 777		SWITCH - (=5518)	4	
-69	20635-02		PLATE - Plexiglas	1	
-70	20635-03		PLATE - Plexiglas	1	
-71	20635-04		PLATE - Plexiglas	1	

A - Used on PA-30 with serial numbers 30-2 to 30-852 inclusive, 30-854 to 30-901 inclusive.

When ordering, always specify Part Number, Description and Serial Number of Aircraft



**1E1**  
**INTENTIONALLY LEFT BLANK**

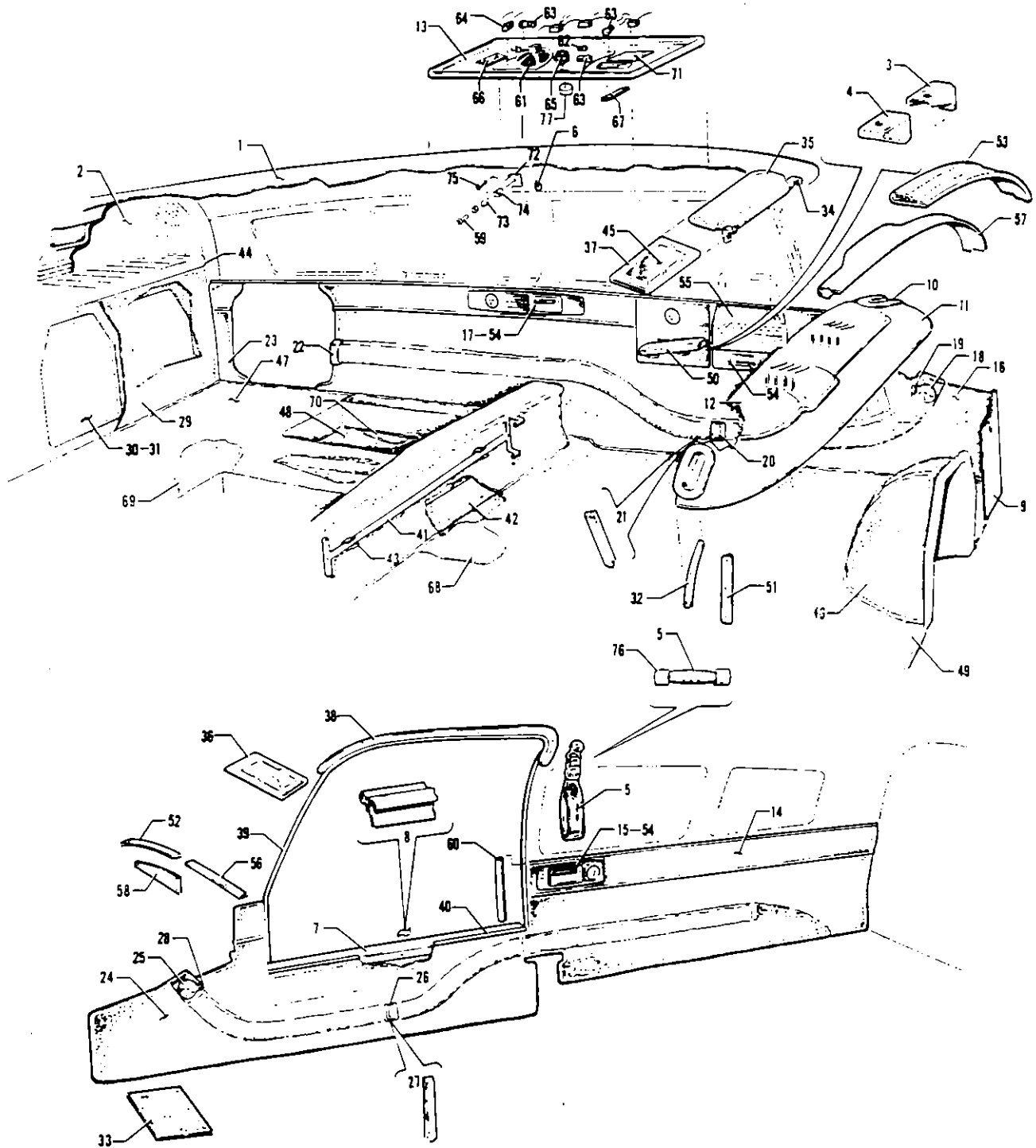

Figure 15A. Cockpit Finishing Installation  
 (PA-30 with Serial Nos. 30-853, 30-902 and up)  
 (PA-39 with Serial Nos. 39-1 and up)



Figure and Index Number	Part Number	Code	NOMENCLATURE	No Req	SERIAL NUMBERS AFFECTED
15A-	25523 - 26725	C B	DRAWING - Cockpit Finishing Installation DRAWING - Cockpit Finishing Installation		
-1	25419-00 26771-00	C B	HEADLINING ASSEMBLY HEADLINING ASSEMBLY	1 1	
-2	25365-00 26319-00 26676-04 26676-05	Y D B B	SHELF ASSEMBLY - Hat, beige SHELF ASSEMBLY - Hat, beige SHELF ASSEMBLY - Hat, beige SHELF ASSEMBLY - Hat, white	1 1 1 1	30-853, 30-902 to 30-165n
-3	25283-00		BRACKET ASSEMBLY - Armrest support	2	
-4	25281-00 25281-02 25281-03		COVER - Armrest support bracket, beige COVER - Armrest support bracket, black COVER - Armrest support bracket, white	2 2 2	
-5	19927-08 19927-09 44347-02 19927-10 44347-10	C F Z F Z	LOOP ASSEMBLY - Assist, beige LOOP ASSEMBLY - Assist, beige HANDLE ASSEMBLY - Assist, beige LOOP ASSEMBLY - Assist, white HANDLE ASSEMBLY - Assist, white	1 1 1 1 1	39-138 and up 39-138 and up
-6	565 446		HANGER - Coat (XP-96208)	2	
-7	20512-00		SILL - Door	1	
-8	24173-00		STRIP - Side panel, retaining	1	
-9	20523-00		PLATE - Cable guard	1	
-10	21336-00 26372-00 26372-01	C B B	PLATE - Handhold PLATE - Handhold, left PLATE - Handhold, right	2 1 1	
-11	22454-00 22454-02	C B	COVER - Cowl, black COVER - Cowl, black	1 1	
-12	22452-00 26330-00 26659-00	Y E B	PANEL ASSEMBLY - Instrument access, black PANEL ASSEMBLY - Instrument access, black PANEL ASSEMBLY - Instrument access, black	1 1 1	30-853, 30-902 to 30-1683
-13	24705-05 26637-02 26637-03 26637-04 26637-05	C Y Y Z Z	PANEL - Cabin light, beige PANEL - Cabin light, beige PANEL - Cabin light, white PANEL - Cabin light, beige PANEL - Cabin light, white	1 1 1 1 1	30-1717, 30-1745 and up 30-1717, 30-1745 and up 39-1 and up 39-1 and up

A - Used on PA-30 with serial numbers 30-853, 30-902 and up, and PA-39 with serial numbers 39-1 and up.  
 B - Used on PA-30 with serial numbers 30-1717, 30-1745 and up, and PA-39 with serial numbers 39-1 and up.  
 C - Used on PA-30 with serial numbers 30-853, 30-902 to 30-1716 inclusive, 30-1718 to 30-1744 inclusive.  
 D - Used on PA-30 with serial numbers 30-1657 to 30-1716 inclusive, 30-1718 to 30-1744 inclusive.  
 E - Used on PA-30 with serial numbers 30-1684 to 30-1716 inclusive, 30-1718 to 30-1744 inclusive.  
 F - Used on PA-30 with serial numbers 30-1717, 30-1745 and up, and PA-39 with serial numbers 39-1 to 39-137 inclusive.  
 Y - Used on PA-30 airplanes only.  
 Z - Used on PA-39 airplanes only.

When ordering, always specify Part Number, Description and Serial Number of Aircraft



Figure and Index Number	Part Number	Code	NOMENCLATURE	No. Req	SERIAL NUMBERS AFFECTED
15A-14	25475-00	CE	PANEL ASSEMBLY - Cockpit, rear, right	1	
	26541-00	BF	PANEL ASSEMBLY - Cockpit, rear, right	1	
-15	489 390	Y	ASH TRAY ASSEMBLY - (#2A17680)	1	30-853, 30-902 to 30-1552
	41609-00	D	ASH TRAY ASSEMBLY	1	
-16	25476-12	CE	PANEL ASSEMBLY - Cockpit, left	1	
	26696-00	BF	PANEL ASSEMBLY - Cockpit, left	1	
-17	489 390	Y	ASH TRAY ASSEMBLY - (#2A17680)	2	30-853, 30-902 to 30-1552
	41609-00	D	ASH TRAY ASSEMBLY	2	
-18	22334-00	C	VALVE - Hot air outlet	1	
	26374-00	F	VALVE - Hot air outlet	1	
-19	471 059		KNOB - (3001-SD)	1	
-20	25533-00	C	PLATE - Hot air outlet	1	
	26656-00	F	PLATE - Hot air outlet	1	
-21	22448-00	F	CLIP - Carpet retaining	1	
-22	25521-00		TRIM - Hot air duct	1	
-23	25477-03	CE	PANEL ASSEMBLY - Cockpit trim, left, rear	1	
	26694-00	BF	PANEL ASSEMBLY - Cockpit trim, left, rear	1	
-24	25498-02	CE	PANEL ASSEMBLY - Cockpit, right, front	1	
	26675-00	BF	PANEL ASSEMBLY - Cockpit, right, front	1	
-25	22334-00	C	VALVE - Hot air outlet	1	
	26374-01	F	VALVE - Hot air outlet	1	
-26	25533-00	C	PLATE - Hot air outlet	1	
	26656-00	F	PLATE - Hot air outlet	1	
-27	22448-00	F	CLIP - Carpet retaining	1	
-28	471 059		KNOB - (3001-SD)	1	
-29	25427-16	CE	PANEL ASSEMBLY - Cockpit, rear	1	
	26189-14	BF	PANEL ASSEMBLY - Cockpit, rear	1	
-30	25427-04	CE	PANEL ASSEMBLY - Insert, right	1	
-31	26189-13	BF	PANEL ASSEMBLY - Insert	2	
-32	21373-00	C	STRIP - Cowl cover attachment, left	1	
	21373-01	C	STRIP - Cowl cover attachment, right	1	
-33	21525-02		PLATE - Heel, left	1	
	21525-03		PLATE - Heel, right	1	
-34	21824-00		SUPPORT - Sun visor	4	
-35	23040-12	C	VISOR ASSEMBLY - Beige	2	
	23040-13	F	VISOR ASSEMBLY - Beige	2	
	23040-14	F	VISOR ASSEMBLY - White	2	

- A - Used on PA-30 with serial numbers 30-853, 30-902 and up, and PA-39 with serial numbers 39-1 and up.
- B - When ordering, specify color red, blue, gold, black or white.
- C - Used on PA-30 with serial numbers 30-853, 30-902 to 30-1716 inclusive, 30-1718 to 30-1744 inclusive.
- D - Used on PA-30 with serial numbers 30-1553 to 30-1716 inclusive, 30-1718 to 30-1744 inclusive.
- E - When ordering, specify color red, blue, brown, gold or black.
- F - Used on PA-30 with serial numbers 30-1717, 30-1745 and up, and PA-39 with serial numbers 39-1 and up.
- Y - Used on PA-30 airplanes only.

When ordering, always specify Part Number, Description and Serial Number of Aircraft



Figure and Index Number	Part Number	Code	NOMENCLATURE	No. Req	SERIAL NUMBERS AFFECTED
15A-36	24849-00	B	PLACARD - Check list	1	39-146 and up
	25698-00	BE	PLACARD - Check list	1	
	26886-00	F	PLACARD - Check list	1	
	27528-00	Z	PLACARD - Check list	1	
-37	24935-00		SLEEVE ASSEMBLY - Sun visor placard	2	
-38	23269-07	B	TRIM STRIP - Door	1	
	26756-02	D	TRIM STRIP - Door, beige	1	
	26756-03	D	TRIM STRIP - Door, white	1	
-39	23305-52	B	STRIP ASSEMBLY - Weather, white (vinyl)	1	
	25156-18	D	STRIP ASSEMBLY - Weather, beige	1	
	25156-20	D	STRIP ASSEMBLY - Weather, white	1	
-40	25156-06	B	STRIP ASSEMBLY - Weather, white	1	
	25156-22	D	STRIP ASSEMBLY - Weather, red	1	
	25156-24	D	STRIP ASSEMBLY - Weather, blue	1	
	25156-26	D	STRIP ASSEMBLY - Weather, white	1	
	25156-28	D	STRIP ASSEMBLY - Weather, black	1	
	25156-30	D	STRIP ASSEMBLY - Weather, gold	1	
-41	18994-06		BAR ASSEMBLY - Tow	1	
-42	25472-00		PLATE ASSEMBLY - Front floor shield	1	
-43	434 982		CLIP - (C4956-020-16)	2	
-44	25567-00		STRIP ASSEMBLY - Hat shelf retainer	1	
-45	31391-00	B	PLACARD - Engine starting instructions, left visor	1	
	26878-00	D	PLACARD - Engine starting instructions, right visor	1	
-46	24075-28	B	CARPET ASSEMBLY - Wheel cover, brown	1	
	24075-26	B	CARPET ASSEMBLY - Wheel cover, red	1	
	24075-23	D	CARPET ASSEMBLY - Wheel cover, red	1	
	24075-27		CARPET ASSEMBLY - Wheel cover, blue	1	
	24075-29		CARPET ASSEMBLY - Wheel cover, gold	1	
	24075-42		CARPET ASSEMBLY - Wheel cover, black	1	
-47	25478-02	Y	CARPET ASSEMBLY - Baggage compartment, red	1	30-853, 30-902 to 30-1552
	25478-06	Y	CARPET ASSEMBLY - Baggage compartment, blue	1	30-853, 30-902 to 30-1552
	25478-10	Y	CARPET ASSEMBLY - Baggage compartment, brown	1	30-853, 30-902 to 30-1552
	25478-14	Y	CARPET ASSEMBLY - Baggage compartment, gold	1	30-853, 30-902 to 30-1552
	25478-22	Y	CARPET ASSEMBLY - Baggage compartment, black	1	30-853, 30-902 to 30-1552
	25478-39	C	CARPET ASSEMBLY - Baggage compartment, brown	1	
	25478-37	C	CARPET ASSEMBLY - Baggage compartment, red	1	
	25478-47	D	CARPET ASSEMBLY - Baggage compartment, red	1	
	25478-38	YZ	CARPET ASSEMBLY - Baggage compartment, blue	1	30-1553 and up, 39-1 and up
	25478-40	YZ	CARPET ASSEMBLY - Baggage compartment, gold	1	30-1553 and up, 39-1 and up
	25478-41	YZ	CARPET ASSEMBLY - Baggage compartment, black	1	30-1553 and up, 39-1 and up

- A - Used on PA-30 with serial numbers 30-853, 30-902 and up, and PA-39 with serial numbers 39-1 and up.
- B - Used on PA-30 with serial numbers 30-853, 30-902 to 30-1716 inclusive, 30-1718 to 30-1744 inclusive.
- C - Used on PA-30 with serial numbers 30-1553 to 30-1716 inclusive, 30-1718 to 30-1744 inclusive.
- D - Used on PA-30 with serial numbers 30-1717, 30-1745 and up, and PA-39 with serial numbers 39-1 and up.
- E - Used if Turbocharger is installed.
- F - Used on PA-30 with serial numbers 30-1717, 30-1745 and up, and PA-39 with serial numbers 39-1 to 39-145 inclusive.
- Y - Used on PA-30 airplanes only.
- Z - Used on PA-39 airplanes only.

When ordering, always specify Part Number, Description and Serial Number of Aircraft



Figure and Index Number	Part Number	Code	NOMENCLATURE	No. Req	SERIAL NUMBERS AFFECTED
15A-48	25479-06	B	CARPET ASSEMBLY - Footwell, brown	2	
	25479-02	B	CARPET ASSEMBLY - Footwell, red	2	
	25479-17	C	CARPET ASSEMBLY - Footwell, red	2	
	25479-04		CARPET ASSEMBLY - Footwell, blue	2	
	25479-08		CARPET ASSEMBLY - Footwell, gold	2	
	25479-10		CARPET ASSEMBLY - Footwell, black	2	
-49	23864-16	B	CARPET ASSEMBLY - Floor, brown	1	
	23864-14	B	CARPET ASSEMBLY - Floor, red	1	
	23864-11		CARPET ASSEMBLY - Floor, red	1	
	23864-15		CARPET ASSEMBLY - Floor, blue	1	
	23864-17		CARPET ASSEMBLY - Floor, gold	1	
	23864-22		CARPET ASSEMBLY - Floor, black	1	
-50	25481-06	B	ARMREST ASSEMBLY - Front, left, brown	1	
	25481-02	B	ARMREST ASSEMBLY - Front, left, red	1	
	25481-24	C	ARMREST ASSEMBLY - Front, left, red (vinyl)	1	
	25481-28	C	ARMREST ASSEMBLY - Front, left, red (leather)	1	
	25481-04		ARMREST ASSEMBLY - Front, left, blue (vinyl)	1	
	25481-32	C	ARMREST ASSEMBLY - Front, left, blue (leather)	1	
	25481-36	C	ARMREST ASSEMBLY - Front, left, gold (vinyl)	1	
	25481-08		ARMREST ASSEMBLY - Front, left, gold (leather)	1	
	25481-20		ARMREST ASSEMBLY - Front, left, black (vinyl)	1	
	25481-40	C	ARMREST ASSEMBLY - Front, left, black (leather)	1	
-51	26768-00	C	STRIP - Side panel trim	2	
-52	26773-03	C	SPACER - Access panel	2	
-53	26616-00	C	COVER ASSEMBLY - Instrument panel trim	1	
-54	41609-00	C	ASH TRAY ASSEMBLY	3	
-55	26565-02	C	PANEL - Cover, beige	1	
	26565-03	C	PANEL - Cover, black	1	
	26565-04	C	PANEL - Cover, white	1	
-56	26773-00	C	SPACER - Access panel	1	
-57	26629-02	Y	PANEL ASSEMBLY - Instrument panel trim	1	30-1717, 30-1745 and up
	26629-04	DZ	PANEL ASSEMBLY - Instrument panel trim	1	39-1 and up
-58	26555-00	C	PLACARD - Operation limitations	1	
-59	411 234	Z	SCREW - (NAS222-15)	4	
	407 565	Z	WASHER - (AN960-416)	4	
-60	24173-02	C	STRIP - Side panel, retaining	1	
-61	21579-00		SPEAKER ASSEMBLY	1	
-62	472 026	Y	LAMP - (=90)	2	
-63	472 038		LAMP - (=93)	3	
-64	487 777	Y	SWITCH - (=5518)	4	
	487 777	Z	SWITCH - (=5518)	2	
-65	484 575	C	RHEOSTAT - (=36232)	1	
-66	20635-03		PLATE - Plexiglas	1	
-67	20635-04	B	PLATE - Plexiglas	1	
	20635-05		PLATE - Plexiglas	1	

A - Used on PA-30 with serial numbers 30-853, 30-902 and up, and PA-39 with serial numbers 39-1 and up.  
 B - Used on PA-30 with serial numbers 30-853, 30-902 to 30-1716 inclusive, 30-1718 to 30-1744 inclusive.  
 C - Used on PA-30 with serial numbers 30-1717, 30-1745 and up, and PA-39 with serial numbers 39-1 and up.  
 D - Used on PA-30 with counter-rotating right engine.  
 Y - Used on PA-30 airplanes only.  
 Z - Used on PA-39 airplanes only.

When ordering, always specify Part Number, Description and Serial Number of Aircraft



Figure and Index Number	Part Number	Code	NOMENCLATURE	No. Req.	SERIAL NUMBERS AFFECTED
15A-68	25694-00		COVER - Carpet, transparent, front	1	
-69	25696-02		COVER - Carpet, transparent, rear	1	
-70	25696-03		COVER - Carpet, transparent, footwell	2	
-71	20635-02		PLATE - Plexiglas	1	
-72	32884-00	Z	PLATE ASSEMBLY - Shoulder harness mounting	4	
-73	29999-10	Z	BUSHING - Shoulder harness plate	4	
-74	29999-11	Z	BUSHING - Shoulder harness plate	4	
-75	410 040	Z	SCREW - (MS24694-S52)	16	
-76	484 464	Z	RETAINER - Handle (383)	2	39-138 and up
-77	571 100	B	KNOB - Rheostat ( 5344-J)	1	

A - Used on PA-30 with serial numbers 30-853, 30-902 and up, and PA-39 with serial numbers 39-1 and up.  
 B - Used on PA-30 with serial numbers 30-1717, 30-1745 and up, and PA-39 with serial nos. 39-1 and up.  
 Z - Used on PA-39 airplanes only.

When ordering, always specify Part Number, Description and Serial Number of Aircraft

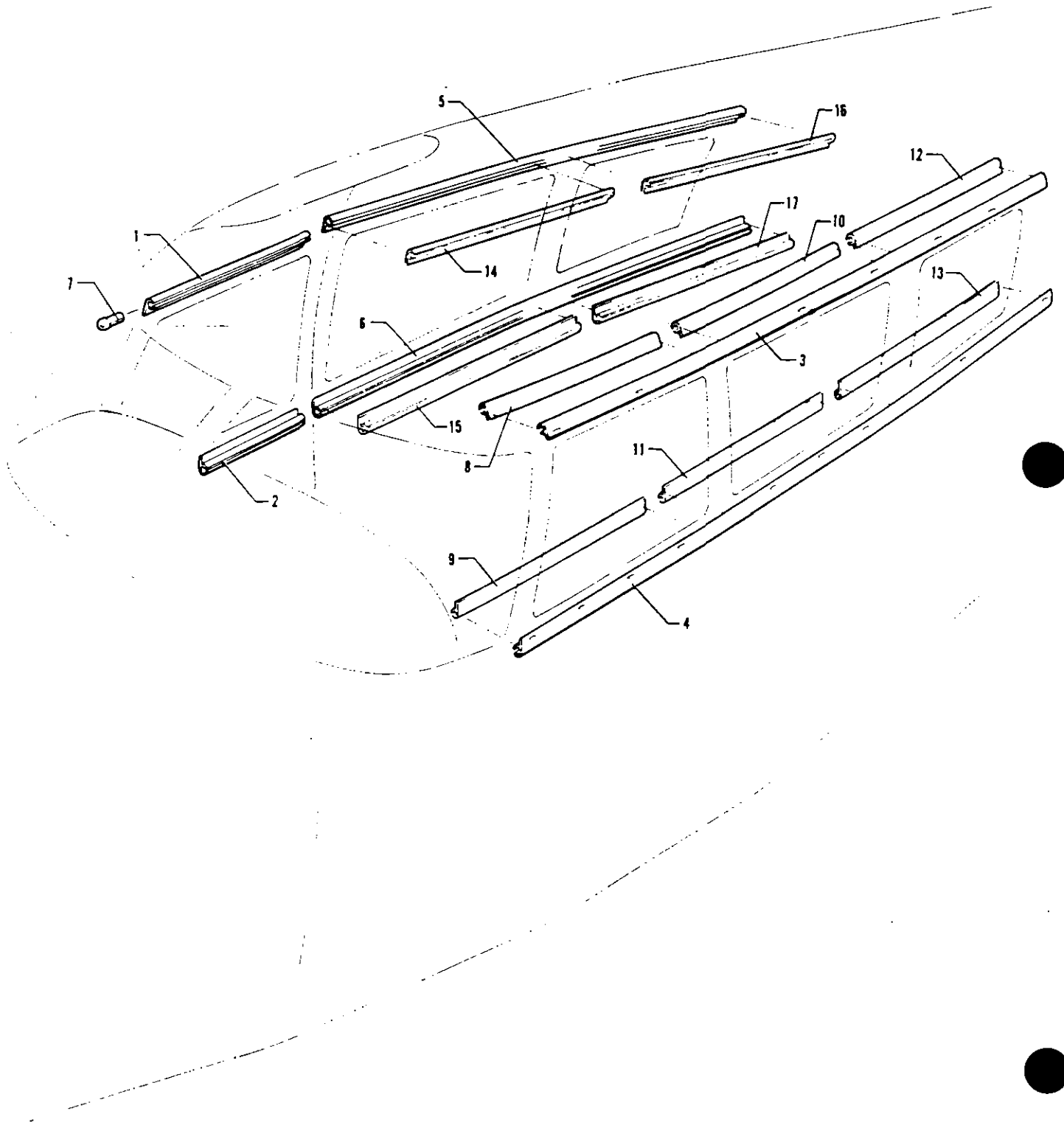

Figure 15B. Window Curtain Installation





Figure and Index Number	Part Number	Code	NOMENCLATURE	No. Req.	SERIAL NUMBERS AFFECTED
15B-	23311	A	DRAWING - Curtain Installation		
	25445	B	DRAWING - Curtain Installation		
	26775	C	DRAWING - Curtain Installation		
-1	24822-02	B	TRACK - Window curtain, right, front, top	1	
	32553-10	C	TRACK - Window curtain, right, front, top	1	
-2	24822-03	B	TRACK - Window curtain, right, front, bottom	1	
	32553-11	C	TRACK - Window curtain, right, front, bottom	1	
-3	24550-05	A	TRACK - Window curtain, left, top	1	
	25412-04	B	TRACK - Window curtain, left, top	1	
-4	24550-04	A	TRACK - Window curtain, left, bottom	1	
	25412-02	B	TRACK - Window curtain, left, bottom	1	
-5	24550-03	A	TRACK - Window, rear, right, top	1	
	25412-05	B	TRACK - Window, rear, right, top	1	
-6	24550-02	A	TRACK - Window, rear, right, bottom	1	
	25412-03	B	TRACK - Window, rear, right, bottom	1	
-7	19161-00	B	STOP - Curtain track	12	
-8	32553-12	C	TRACK - Window curtain, left, front, top	1	
-9	32553-24	C	TRACK - Window curtain, left, front, bottom	1	
-10	32553-16	C	TRACK - Window curtain, left, center, top	1	
-11	32553-13	C	TRACK - Window curtain, left, center, bottom	1	
-12	32553-17	C	TRACK - Window curtain, left, rear, top	1	
-13	32553-18	C	TRACK - Window curtain, left, rear, bottom	1	
-14	32553-14	C	TRACK - Window curtain, right, center, top	1	
-15	32553-15	C	TRACK - Window curtain, right, center, bottom	1	
-16	32553-20	C	TRACK - Window curtain, right, rear, top	1	
-17	32553-19	C	TRACK - Window curtain, right, rear, bottom	1	

A - Used on PA-30 with serial numbers 30-2 to 30-852 inclusive, 30-854 to 30-901 inclusive.  
 B - Used on PA-30 with serial numbers 30-853, 30-902 to 30-1716 inclusive, 30-1718 to 30-1744 inclusive.  
 C - Used on PA-30 with serial numbers 30-1717, 30-1745 and up, and PA-39 with serial numbers 39-1 and up.

Note: Individual curtains not available. See curtain kits on Optional Equipment Kit page.

When ordering, always specify Part Number, Description and Serial Number of Aircraft

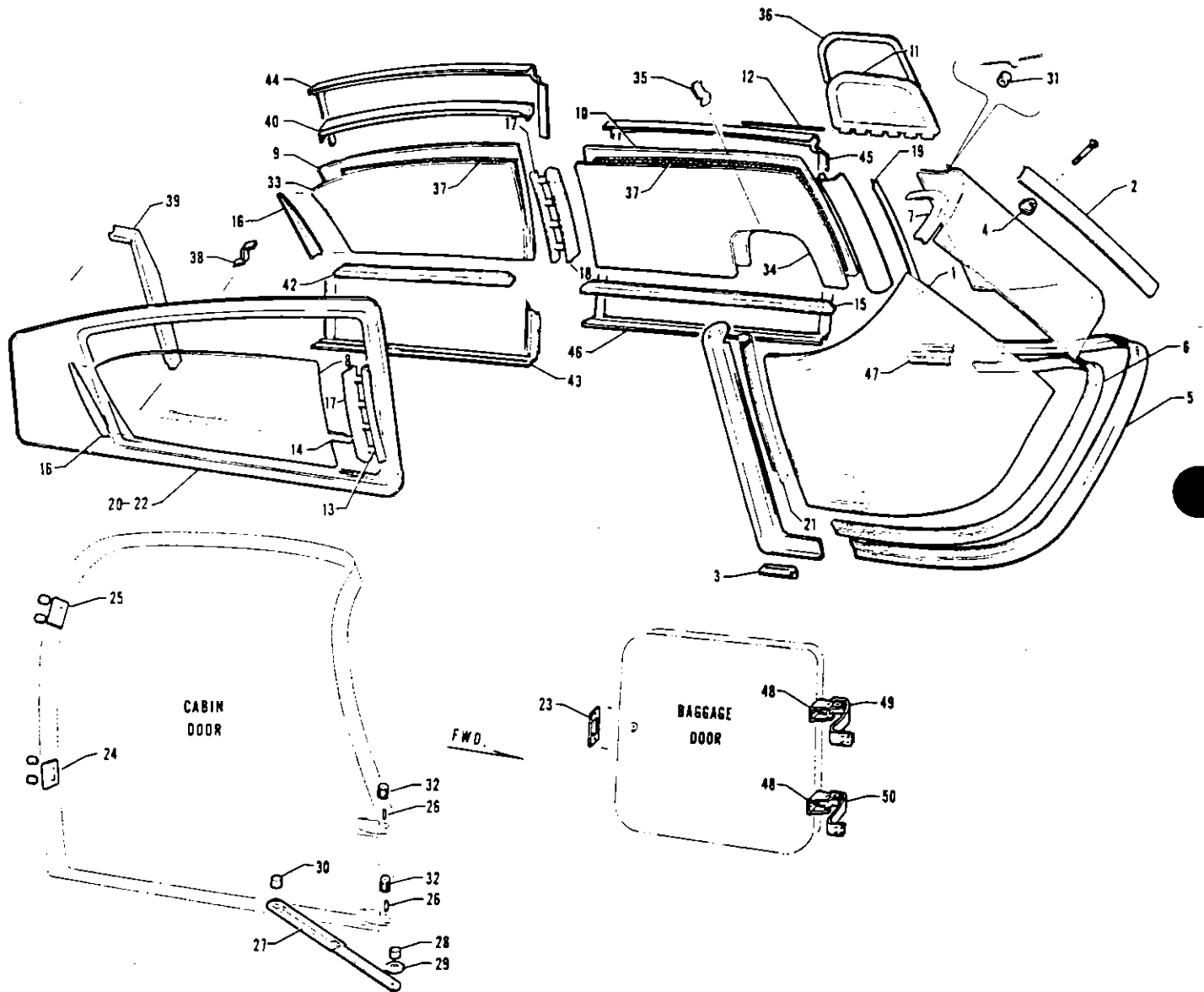

Figure 16. Enclosure Installation  
 (PA-30 with Serial Nos. 30-2 to 30-852, 30-854 to 30-901 inclusive)



Figure and Index Number	Part Number	Code	NOMENCLATURE	No. Req.	SERIAL NUMBERS AFFECTED
16-	24044 20677 24076		DRAWING - Window Installation DRAWING - Windshield Installation DRAWING - Fuselage Assembly		
-1	20677-10 20677-09		WINDSHIELD ASSEMBLY - Left WINDSHIELD ASSEMBLY - Right	1 1	
-2	20715-00		TRIM STRIP - Windshield, center	1	
-3	20719-00		TRIM STRIP - Windshield, left	1	
	20719-01		TRIM STRIP - Windshield, right	1	
-4	18359-00 406 701		NUT - Tubular NUT - Cap	5 5	
-5	20677-08		COLLAR - Windshield, outside	1	
-6	20677-05		COLLAR - Windshield, inside	1	
-7	20677-06 20677-07		ANGLE - Windshield, top, left ANGLE - Windshield, top, right	1 1	
-8	20672-01		WINDOW - Rear, right	1	
-9	20672-00		WINDOW - Rear, left	1	
-10	20676-00		WINDOW - Front, left	1	
-11	21027-00		WINDOW ASSEMBLY - Storm	1	
-12	21025-04		PIN - Storm window hinge	1	
-13	14843-10		BUSHING	8	
-14	20669-04		ANGLE - Left rear window, bottom	1	
	20669-03		ANGLE - Right rear window, bottom	1	
-15	21914-02		TRIM STRIP - Window, bottom	1	
-16	20669-10 20669-09		ANGLE - Left rear window, rear ANGLE - Right rear window, rear	1 1	
-17	23128-04 23128-02		ANGLE - Left rear window, front ANGLE - Right rear window, front	1 1	
-18	23128-03		ANGLE - Left front window, rear	1	
-19	20669-08		ANGLE - Left front window, front	1	
-20	23313-02 23313-03 23313-05 23313-06		MOULDING - Window, right rear, brown MOULDING - Window, right rear, charcoal MOULDING - Window, right rear, brown MOULDING - Window, right rear, charcoal	1 1 1 1	30-2 to 30-261 inclusive 30-2 to 30-261 inclusive 30-262 and up 30-262 and up
-21	23314-02 23314-03		MOULDING - Window, right front, charcoal MOULDING - Window, right front, brown	1 1	
-22	23315-02 23315-03 23315-05 23315-06		MOULDING - Window, left side, charcoal MOULDING - Window, left side, brown MOULDING - Window, left side, charcoal MOULDING - Window, left side, brown	1 1 1 1	30-2 to 30-261 inclusive 30-2 to 30-261 inclusive 30-262 and up 30-262 and up
-23	24218-00		PLATE - Baggage door latch striker	1	
-24	22609-00		PLATE - Cabin door latch striker, lower	1	
-25	22616-00		PLATE - Cabin door latch striker, upper	1	
-26	20830-00		HINGE - Door pin	2	
-27	760 503	B	KIT - Cabin door holder replacement	1	

A - Used on PA-30 with serial numbers 30-2 to 30-853 inclusive, 30-854 to 30-901 inclusive.

B - If existing door holder incorporates a nylon sliding block, order door holder 27072-02.

When ordering, always specify Part Number, Description and Serial Number of Aircraft

## PIPER PARTS CATALOG

Figure and Index Number	Part Number	Code	NOMENCLATURE	No. Req.	SERIAL NUMBERS AFFECTED
16-28	14843-89		BUSHING - Door holder, length 3/16"	1	
	39994-11		BUSHING - Door holder, length 3/32"	1	
-29	14843-78		BUSHING - Door holder, length 13/64"	1	
-30	86102-27		BUSHING - Door holder, length 9/32"	1	
	39994-11		BUSHING - Door holder, length 3/32"	1	
-31	14843-99		BUSHING - Windshield spacer	6	
-32	21741-00		BUSHING - Serrated door hinge, eccentric	2	
	21741-02		BUSHING - Serrated door hinge, concentric	2	
-33	20672-02		WINDOW ASSEMBLY - Rear inside	2	
-34	24020-00		WINDOW - Front inside, left	1	
-35	24019-00		CLIP - Window attachment, inside	4	
-36	24042-00		STRIP - Window retainer, storm window	1	
-37	85512-12		STRIP - Left front inside window spacer 98"	1	
	85512-13		STRIP - Left and right rear inside window spacer 80"	2	
-38	23287-00		CLIP - Stringer support, left	1	
	23287-01		CLIP - Stringer support, right	1	
-39	23289-00		STRINGER - Window moulding, rear, LH	1	30-2 to 30-261 inclusive
	23289-01		STRINGER - Window moulding, rear, RH	1	30-2 to 30-261 inclusive
-40	23290-00		STRINGER - Window moulding, rear, top, LH	1	30-2 to 30-261 inclusive
	23290-01		STRINGER - Window moulding, rear, top, RH	1	30-2 to 30-261 inclusive
-41	23297-02		STRINGER - Window moulding, front, bottom, LH	1	30-2 to 30-261 inclusive
-42	23297-03		STRINGER - Window moulding, rear, bottom, LH	1	30-2 to 30-261 inclusive
	23297-04		STRINGER - Window moulding, rear, bottom, RH	1	30-2 to 30-261 inclusive
-43	23291-02		STRIP - Window moulding, rear, bottom, LH	1	
	23291-03		STRIP - Window moulding, rear, bottom, RH	1	
-44	23291-04		STRIP - Window moulding, rear, top, LH	1	
	23291-05		STRIP - Window moulding, rear, top, RH	1	
-45	23293-02		STRIP - Window moulding, front, top, LH	1	
-46	23293-03		STRIP - Window moulding, front, bottom, LH	1	
-47	23295-03		STRIP - Windshield moulding	2	
-48	22556-00		BRACKET - Baggage door hinge	2	
-49	22552-02		HINGE ASSEMBLY - Baggage door, top	1	
-50	22552-03		HINGE - Baggage door, bottom	1	
<p>A - Used on PA-30 with serial numbers 30-2 to 30-852 inclusive, 30-854 to 30-901 inclusive.</p>					

When ordering, always specify Part Number, Description and Serial Number of Aircraft

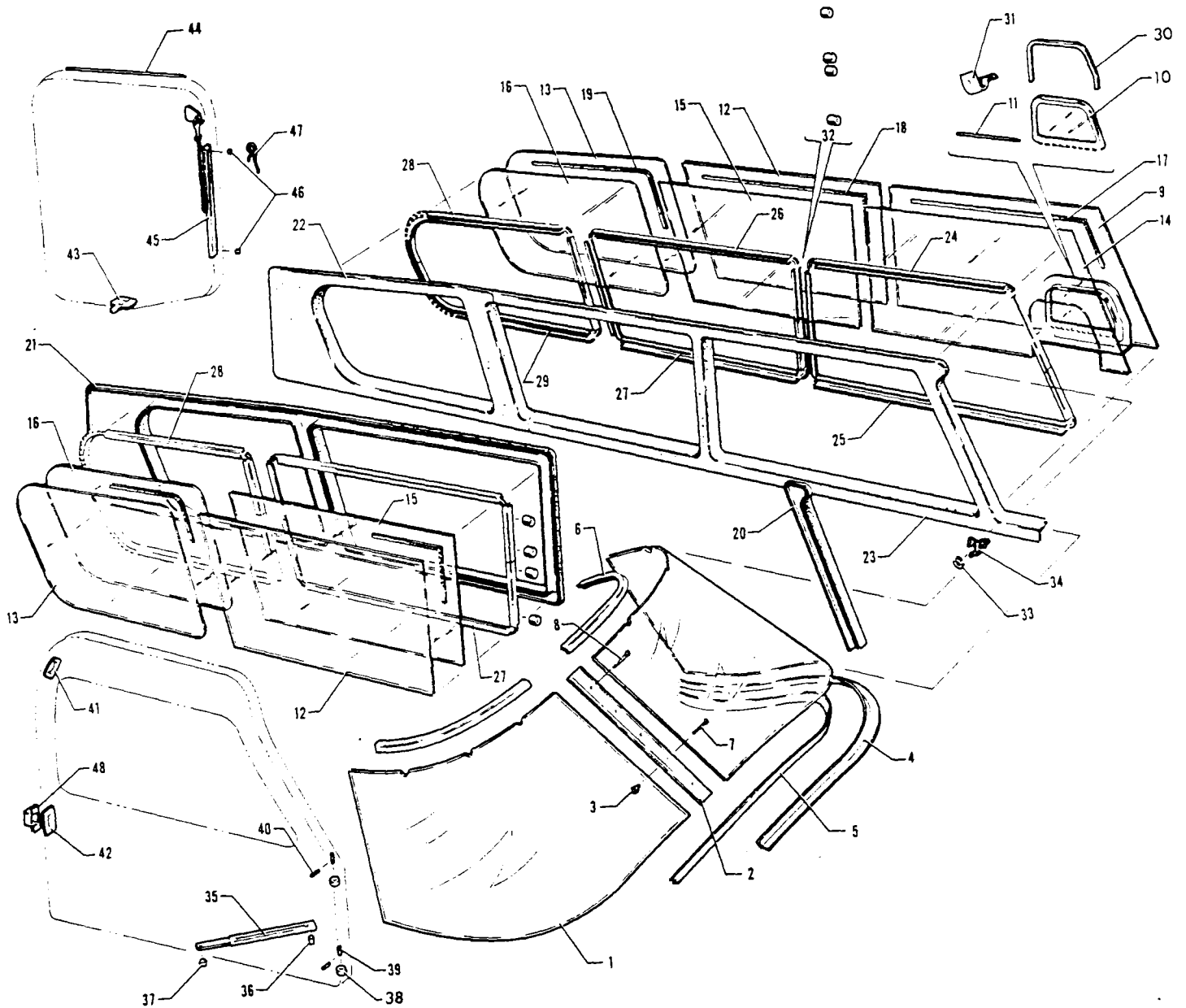

Figure 16A. Enclosure Installation  
(PA-30 with Serial Nos. 30-853, 30-902 and up)  
(PA-39 with Serial Nos. 39-1 and up)

SECTION II  
Fuselage Group



ENCLOSURE INSTALLATION  
(See Code "A")

Figure and Index Number	Part Number	Code	NOMENCLATURE	No. Req	SERIAL NUMBERS AFFECTED
16A-	25530	B	DRAWING - Fuselage (Complete)		
	26726	C	DRAWING - Fuselage (Complete)		
	20677		DRAWING - Windshield Installation		
	25440	B	DRAWING - Window Installation		
	26782	C	DRAWING - Window Installation		
-1	20677-10	Y	WINDSHIELD ASSEMBLY - Left	1	30-853, 30-902 to 30-1701
	20677-14	YZ	WINDSHIELD ASSEMBLY - Left	1	30-1702 and up, 39-1 and up
	20677-09	Y	WINDSHIELD ASSEMBLY - Right	1	30-853, 30-902 to 30-1701
	20677-13	YZ	WINDSHIELD ASSEMBLY - Right	1	30-1702 and up, 39-1 and up
-2	20715-00		TREM STRIP - Windshield, center	1	
-3	18359-00		NUT - Tubular	5	
	406 701		NUT - Cap	5	
-4	20677-08		COLLAR - Windshield, outside	1	
-5	20677-05		COLLAR - Windshield, inside	1	
-6	20677-06		ANGLE - Windshield, top, left	1	
	20677-07		ANGLE - Windshield, top, right	1	
-7	415 266		SCREW - Center (used with tubular nut)	3	
	415 270		SCREW - Center (used with cap nut)	3	
-8	415 264		SCREW - Upper and lower (used with tubular nut)	2	
	415 266		SCREW - Upper and lower (used with cap nut)	2	
-9	20676-03		WINDOW - Front, left, outer	1	
-10	21027-00		WINDOW ASSEMBLY - Storm	1	
-11	21025-04		PIN - Storm window hinge	1	
-12	25496-02		WINDOW - Center, left, outer	1	
	25496-03		WINDOW - Center, right, outer	1	
-13	25497-02		WINDOW - Rear, left, outer	1	
	25497-03		WINDOW - Rear, right, outer	1	
-14	24020-00		WINDOW - Front, left, inner	1	
-15	25496-04		WINDOW - Center, inner	2	
-16	25497-04		WINDOW - Rear, inner	2	
-17	85512-12		STRIP - Window spacer, front, left	1	
-18	85512-20		STRIP - Window spacer, center	2	
-19	85512-21		STRIP - Window spacer, rear	2	
-20	23314-06		MOULDING - Window, front, right, beige	1	
	23314-07	C	MOULDING - Window, front, right, white	1	
-21	25416-00	B	MOULDING ASSEMBLY - Window, front, right, beige	1	
	26710-06	C	MOULDING ASSEMBLY - Window, front, right, beige	1	
	26710-07	C	MOULDING ASSEMBLY - Window, front, right, white	1	
-22	25417-00	B	MOULDING - Window, rear, left, beige	1	
	26718-02	C	MOULDING - Window, rear, left, beige	1	
	26718-03	C	MOULDING - Window, rear, left, white	1	
-23	25418-00	B	MOULDING - Window, front, left, beige	1	
	26668-02	C	MOULDING - Window, front, left, beige	1	
	26668-03	C	MOULDING - Window, front, left, white	1	
			A - Used on PA-30 with serial numbers 30-853, 30-902 and up, and PA-39 with serial numbers 39-1 and up.		
			B - Used on PA-30 with serial numbers 30-853, 30-902 to 30-1716 inclusive, 30-1718 to 30-1744 inclusive.		
			C - Used on PA-30 with serial numbers 30-1717, 30-1745 and up, and PA-39 with serial numbers 39-1 and up.		
			Y - Used on PA-30 airplanes only.		
			Z - Used on PA-39 airplanes only.		

When ordering, always specify Part Number, Description and Serial Number of Aircraft



Figure and Index Number	Part Number	Code	NOMENCLATURE	No. Req.	SERIAL NUMBERS AFFECTED
16A-24	23293-02		STRIP - Front window retaining, upper, left	1	
-25	23293-03		STRIP - Front window retaining, lower, left	1	
-26	25414-02		STRIP - Center window retaining, upper, left	1	
	25414-03		STRIP - Center window retaining, upper, right	1	
-27	25414-04		STRIP - Center window retaining, lower, left	1	
	25414-05		STRIP - Center window retaining, lower, right	1	
-28	25415-02		STRIP - Rear window retaining, upper, left	1	
	25415-03		STRIP - Rear window retaining, upper, right	1	
-29	25415-04		STRIP - Rear window retaining, lower, left	1	
	25415-05		STRIP - Rear window retaining, lower, right	1	
-30	24042-00		STRIP - Window retainer, storm window	1	
-31	24019-00		CLIP - Storm window strip	4	
-32	14843-10	Y	BUSHING - Spacer	8	30-853, 30-902 to 30-95n
-33	23302-00		WASHER - Retaining, microphone holder	1	
-34	23303-00		HOLDER - Microphone (Used with Telephonics Mike RS-38A)	1	
	453 415		BRACKET - Microphone (Used with Telex Mike 66C)	1	
-35	760 503	BC	KIT - Cabin door holder replacement	1	
	27072-02	Z	HOLDER ASSEMBLY - Cabin door (with nylon sliding block)	1	39-48 and up
-36	86102-27		BUSHING - Door holder, front, length 9/32"	1	
	39994-11		BUSHING - Door holder, front, length 3/32"	1	
-37	14843-78		BUSHING - Door holder, rear, length 13/64"	1	
	39994-11		BUSHING - Door holder, rear, length 3/32"	1	
-38	21741-00		BUSHING - Serrated, door hinge, off center	2	
	21741-02		BUSHING - Serrated, door hinge, not off center	2	
-39	20830-00		PIN - Cabin door hinge	2	
-40	480 688		PIN - Roll door hinge (59-012-062-0500)	2	
-41	22616-00		PLATE - Cabin door auxiliary latch striker	1	
-42	22609-00		PLATE - Cabin door latch striker	1	
-43	25463-00		PLATE - Baggage door latch striker	1	
-44	81761-58		PIN - Baggage door hinge	1	
-45	30355-00		CHANNEL - Baggage door holder guide	1	
-46	01402-51		BUSHING - Baggage door guide channel	2	
-47	25330-00		SPRING - Baggage door holder retainer	1	
-48	22608-00		RECEPTACLE ASSEMBLY - Cabin door latch	1	

A - Used on PA-30 with serial numbers 30-853, 30-902 and up, and PA-39 with serial numbers 39-1 and up.  
 B - Used on PA-30 with serial numbers 30-853, 30-902 and up, and PA-39 with serial numbers 39-1 to 39-47 inclusive.  
 C - If existing door holder incorporates a nylon sliding block, order door holder 27072-02.  
 Y - Used on PA-30 airplanes only.  
 Z - Used on PA-39 airplanes only.

When ordering, always specify Part Number, Description and Serial Number of Aircraft

**1 E16**

**INTENTIONALLY LEFT BLANK**



# PIPER PARTS CATALOG

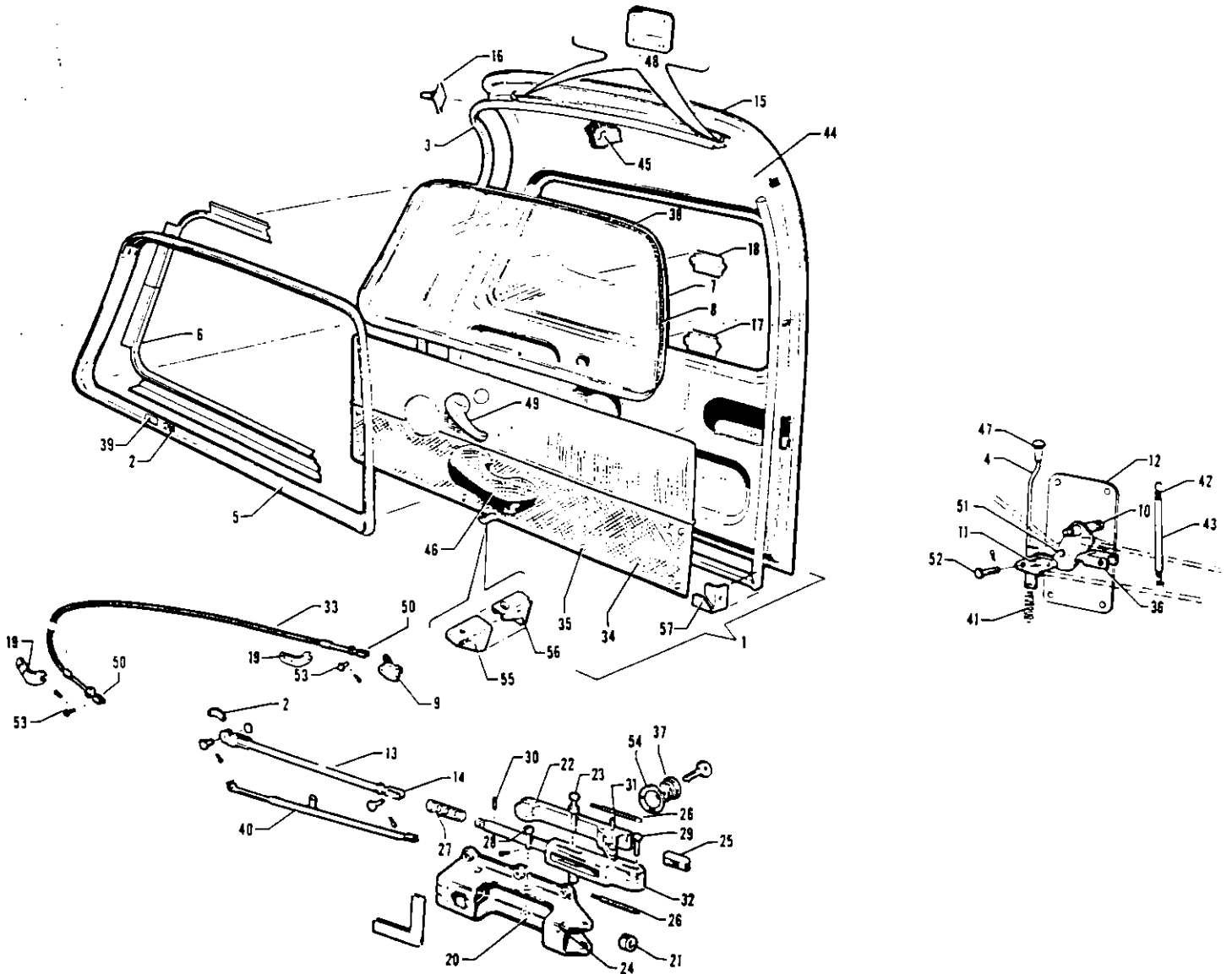

Figure 17. Cabin Door

REVISED: MAY 1980

1E17

PA-30  
PA-36



Figure and Index Number	Part Number	Code	NOMENCLATURE	No. Req.	SERIAL NUMBERS AFFECTED
17-1	23885-00	BC	DOOR ASSEMBLY - Cabin (complete)	1	
	25524-00	DE	DOOR ASSEMBLY - Cabin (complete)	1	
	26687-00	FH	DOOR ASSEMBLY - Cabin (complete)	1	
-2	19941-00		PLACARD - Door lock	1	
-3	19063-02		MOULDING - Door seal	12	
-4	23350-03		ROD ASSEMBLY - Door lock release	1	
-5	23308-02	C	WINDOW MOULDING - Charcoal	1	
	23308-03	C	WINDOW MOULDING - Brown	1	
	23308-06	E	WINDOW MOULDING - Beige	1	
	26677-02	H	WINDOW MOULDING - Beige	1	
	26677-03	H	WINDOW MOULDING - White	1	
-6	23294-02		STRIP - Window retaining, bottom	1	
	23294-03		STRIP - Window retaining, top	1	
-7	20923-11		WINDOW - Cabin door, outside	1	
-8	24117-00		WINDOW - Cabin door, inside	1	
-9	22615-00		ARM ASSEMBLY - Door lock	1	
-10	23340-00	Y	SHAFT ASSEMBLY - Inside door handle	1	30-2 to 30-170 inclusive, 30-172 to 30-241 inclusive
	23346-04	G	SHAFT ASSEMBLY - Inside door handle	1	
	26781-00	H	SHAFT ASSEMBLY - Inside door handle	1	
-11	23353-00	Y	SHAFT ASSEMBLY - Door latch plate	1	30-2 to 30-170 inclusive, 30-172 to 30-241 inclusive
	23353-04	YZ	SHAFT ASSEMBLY - Door latch plate	1	30-171, 30-242 and up, 39-1 and up
-12	23349-00	A	PLATE - Door handle shaft retainer	1	
	23349-02	H	PLATE - Door handle shaft retainer	1	
-13	23354-00		TUBE ASSEMBLY - Door latch	1	
-14	16514-00		CLEVIS	1	
	404 322		NUT - (AN310-4R)	1	
-15	23360-06	A	DOOR ASSEMBLY - Cabin	1	
	23360-09	H	DOOR ASSEMBLY - Cabin	1	
-16	20742-00		PIN ASSEMBLY - Door retainer	1	
-17	20629-00		HINGE - Cabin door, lower	1	
-18	20629-01		HINGE - Cabin door, upper	1	
-19	22653-00		CLIP - Door latch cable	2	

- A - Used on PA-30 with serial numbers 30-2 to 30-1716 inclusive. 30-1718 to 30-1744 inclusive.
- B - When ordering, specify color red, blue or brown.
- C - Used on PA-30 with serial numbers 30-2 to 30-852 inclusive, 30-854 to 30-901 inclusive.
- D - When ordering, specify color red, blue, brown, gold or black.
- E - Used on PA-30 with serial numbers 30-852, 30-902 to 30-1716 inclusive, 30-1718 to 30-1744 inclusive.
- F - When ordering, specify color red, blue, white, black or gold.
- G - Used on PA-30 with serial numbers 30-171, 30-242 to 30-1710 inclusive, 30-1718 to 30-1744 inclusive.
- H - Used on PA-30 with serial numbers 30-1717, 30-1745 and up. and PA-39 with serial numbers 39-1 and up.
- Y - Used on PA-30 airplanes only.
- Z - Used on PA-39 airplanes only.

When ordering, always specify Part Number, Description and Serial Number of Aircraft



Figure and Index Number	Part Number	Code	NOMENCLATURE	No. Req.	SERIAL NUMBERS AFFECTED
17-20	22840-02		LATCH ASSEMBLY - Door	1	
-21	14976-08		BUSHING	2	
-22	22641-00		HANDLE	1	
-23	22676-00		PIN	1	
-24	22839-00		HOUSING ASSEMBLY	1	
-25	60054-14		LINK	5	
-26	83302-47		SPRING	2	
-27	83302-48		SPRING	1	
-28	424 182		PIN - Flat head (AN393-27)	1	
-29	424 184		PIN - Flat head (AN393-31)	1	
-30	480 706		PIN - Roll	2	
-31	480 683		PIN - Roll	1	
-32	22679-04		LATCH	1	
-33	22860-02		CABLE ASSEMBLY - Flexible push-pull control	1	
-34	23270-09	A	PANEL ASSEMBLY - Door trim, sand	1	
	23270-14	AE	PANEL ASSEMBLY - Door trim	1	
	25510-00	BD	PANEL ASSEMBLY - Door trim	1	
	26679-00	FG	PANEL ASSEMBLY - Door trim	1	
-35	460 027		FASTENER	7	
-36	23552-00	C	STOP ASSEMBLY - Door handle	1	
-37	30426-06	Y	KIT ASSEMBLY - Cabin and baggage door locks	1	30-2 to 30-754 inclusive
	25163-05	YZ	KIT ASSEMBLY - Cabin and baggage door locks	1	30-755 and up, 39-1 and up
-38	85512-14		STRIP - Sponge rubber 83"	1	
-39	23240-00		PLACARD - Door lock	1	
-40	23356-00		ROD ASSEMBLY - External lock release	1	
-41	83302-53		SPRING - Coil	1	
-42	83302-53		SPRING - Coil	1	
-43	90797-90		SLEEVE	1	
-44	21995-05	A	COVER - Door trim, sand	1	
	21995-06	A	COVER - Door trim, gray	1	
	21995-08	B	COVER - Door trim, beige	1	
	21995-09	G	COVER - Door trim, beige	1	
	21995-10	G	COVER - Door trim, white	1	
-45	23355-00		PAD - Door trim cover	1	

- A - Used on PA-30 with serial numbers 30-2 to 30-852 inclusive, 30-854 to 30-901 inclusive.
- B - Used on PA-30 with serial numbers 30-853, 30-902 to 30-1716 inclusive, 30-1718 to 30-1744 inclusive.
- C - Used on PA-30 with serial numbers 30-2 to 30-1716 inclusive, 30-1718 to 30-1744 inclusive.
- D - When ordering specify color red, blue, brown, gold or black.
- E - When ordering specify color red or blue.
- F - When ordering specify color red, blue, white, black or gold.
- G - Used on PA-30 with serial numbers 30-1717, 30-1745 and up. and PA-39 with serial numbers 39-1 and up.
- Y - Used on PA-30 airplanes only.
- Z - Used on PA-39 airplanes only.

When ordering, always specify Part Number, Description and Serial Number of Aircraft



Figure and Index Number	Part Number	Code	NOMENCLATURE	No. Req	SERIAL NUMBERS AFFECTED
17-46	23463-10	A	ARMREST ASSEMBLY - Vinyl, sand	1	
	23463-11	A	ARMREST ASSEMBLY - Vinyl, red	1	
	23463-12	A	ARMREST ASSEMBLY - Vinyl, blue	1	
	25481-03	B	ARMREST ASSEMBLY - Vinyl, red	1	
	25481-07	B	ARMREST ASSEMBLY - Vinyl, brown	1	
	25481-09	E	ARMREST ASSEMBLY - Leather, gold	1	
	25481-05	E	ARMREST ASSEMBLY - Vinyl, blue	1	
	25481-31	D	ARMREST ASSEMBLY - Leather, blue	1	
	25481-23	D	ARMREST ASSEMBLY - Vinyl, red	1	
	25481-27	D	ARMREST ASSEMBLY - Leather, red	1	
	25481-35	D	ARMREST ASSEMBLY - Vinyl, gold	1	
	25481-19	E	ARMREST ASSEMBLY - Vinyl, black	1	
	25481-39	E	ARMREST ASSEMBLY - Leather, black	1	
-47	471 091		KNOB - Door lock, tan	1	
	471 092		KNOB - Door lock, gray	1	
-48	11199-06		PLATE - Cover	2	
-49	464 022	C	HANDLE - Door, inside	1	
	464 031	D	HANDLE - Door, inside	1	
-50	554 757		CLEVIS - (MS35812-1)	2	
-51	424 176		PIN - Flat head (MS20392-1C15)	1	
	407 564		WASHER - (AN960-10)	1	
	424 051		PIN - Cotter (MS24665-132)	1	
-52	424 144		PIN - Flat head (MS20392-2C15)	1	
	407 562		WASHER - (AN960-6)	1	
	424 051		PIN - Cotter (MS24665-132)	1	
-53	424 176		PIN - Flat head (MS20392-2C15)	2	
-54	25590-00	E	WASHER - Door lock	1	
-55	25281-00	E	COVER - Armrest support bracket, beige	2	
	25281-02		COVER - Armrest support bracket, black	2	
	25281-03	D	COVER - Armrest support bracket, white	2	
-56	25283-00	E	BRACKET ASSEMBLY - Armrest support	2	
-57	24164-00		BRACKET - Door trim reinforcing	2	

- A - Used on PA-30 with serial numbers 30-2 to 30-852 inclusive. 30-354 to 30-901 inclusive.
- B - Used on PA-30 with serial numbers 30-853, 30-902 to 30-1716 inclusive. 30-1718 to 30-1744 inclusive.
- C - Used on PA-30 with serial numbers 30-2 to 30-1716 inclusive. 30-1718 to 30-1744 inclusive.
- D - Used on PA-30 with serial numbers 30-1717, 30-1745 and up, and PA-39 with serial numbers 39-1 and up.
- E - Used on PA-30 with serial numbers 30-853, 30-902 and up, and PA-39 with serial numbers 39-1 and up.

When ordering, always specify Part Number, Description and Serial Number of Aircraft

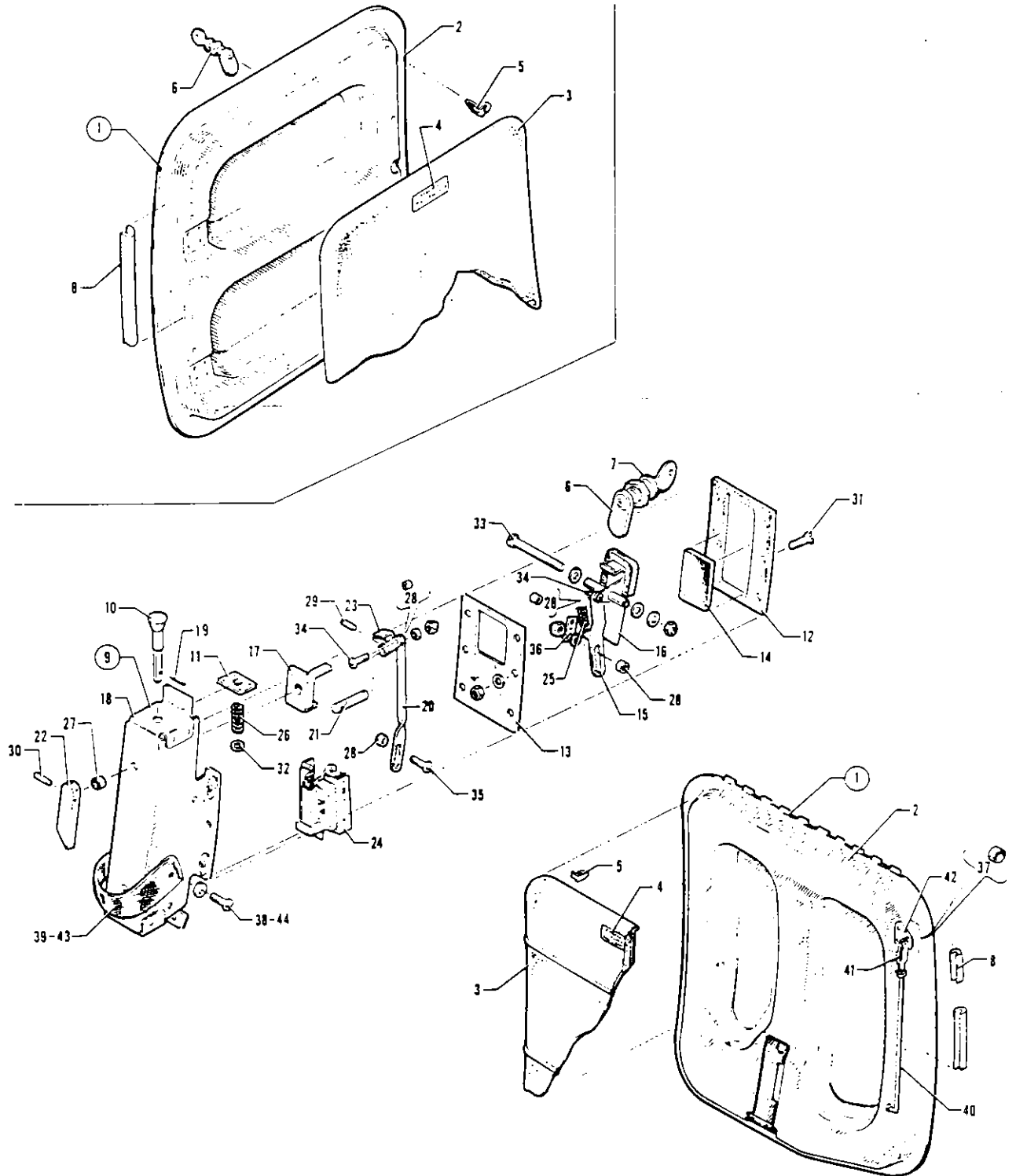

Figure 17A. Baggage Compartment Door Assembly

REVISED: FEBRUARY 1977

1E21

PA-30  
PA-39

PIPER PARTS CATALOG

Figure and Index Number	Part Number	Code	NOMENCLATURE	No. Req.	SERIAL NUMBERS AFFECTED
17A-1	23184-00	A	DOOR ASSEMBLY - Baggage compartment (complete)	1	
	25509-02	CG	DOOR ASSEMBLY - Baggage compartment (complete)	1	
	26724-00	BH	DOOR ASSEMBLY - Baggage compartment (complete)	1	
-2	22570-00	A	* DOOR ASSEMBLY - Baggage compartment	1	
	25506-00	J	* DOOR ASSEMBLY - Baggage compartment	1	
-3	23900-00	A	* PANEL ASSEMBLY - Baggage compartment door	1	
	25508-00	CG	* PANEL ASSEMBLY - Baggage compartment door	1	
	26758-00	BH	* PANEL ASSEMBLY - Baggage compartment door	1	
-4	24031-00	A	* * PLACARD - Baggage door (maximum weight)	1	
	25541-00	J	* * PLACARD - Baggage door (emergency exit)	1	
-5	460 027		* * FASTENER - Baggage door	14	
-6	30426-06	Y	* KIT ASSEMBLY - Cabin and baggage door locks	1	30-2 to 30-741 inclusive
	25163-05	YZ	* KIT ASSEMBLY - Cabin and baggage door locks	1	30-742 and up, 39-1 and up
-7	25590-00	J	* WASHER - Door lock trim	1	
-8	23183-00		* MOULDING - Baggage door seal	8'	
-9	25489-00	J	* LATCH ASSEMBLY - Baggage door (complete)	1	
-10	25782-00	FK	* * KNOB - Door lock (2 1/4" long)	1	
-11	25425-00	J	* * BEARING ASSEMBLY - Door locking arm shaft	1	
-12	25428-00	J	* * PLATE - Baggage door, latch spacer	1	
-13	25429-00	J	* * PLATE - Baggage door, latch spacer	1	
-14	25432-00	J	* * SEAL - Baggage door, latch spacer	1	
-15	25437-00	J	* * LINK - Baggage door, latch spacer	1	
-16	25438-00	J	* * HANDLE ASSEMBLY - Baggage door latch	1	
-17	25444-00	J	* * BEARING ASSEMBLY - inside handle shaft	1	
-18	25447-00	J	* * COVER ASSEMBLY - Baggage door, latch	1	
-19	424 051	J	* * PIN - Cotter (MS24665-132)	1	
-20	25456-00	J	* * LINK - Baggage door, inside handle	1	
-21	25457-00	J	* * ROD - Baggage door, inside handle	1	
-22	25460-00	J	* * HANDLE - Baggage door, inside	1	
-23	25464-00	J	* * ARM ASSEMBLY - Baggage door, latch	1	
-24	25473-00	J	* * LATCH ASSEMBLY - Baggage door	1	
-25	83302-66	DFJ	* * SPRING - Baggage door handle (2" long)	1	
	83302-47	EK	* * SPRING - Baggage door handle (1 3/8" L)	2	

- A - Used on PA-30 with serial numbers 30-2 to 30-852 inclusive, 30-854 to 30-901 inclusive.
- B - When ordering, specify color red, blue, black, white or gold.
- C - When ordering, specify color red, blue, brown, gold or black.
- D - Used when door lock knob is 1 1/16" long
- E - Used when door lock knob is 2 1/4" long.
- F - Used on PA-30 with serial numbers 30-853, 30-902 to 30-1158, 30-1160 to 30-1200 inclusive.
- G - Used on PA-30 with serial numbers 30-853, 30-902 to 30-1716 inclusive, 30-1718 to 30-1744 inclusive.
- H - Used on PA-30 with serial numbers 30-1717, 30-1745 and up, and PA-39 with serial numbers 39-1 and up.
- J - Used on PA-30 with serial numbers 30-853, 30-902 and up, and PA-39 with serial numbers 39-1 and up.
- K - Used on PA-30 with serial numbers 30-1159, 30-1201 and up, and PA-39 with serial numbers 39-1 and up.
- Y - Used on PA-30 airplanes only.
- Z - Used on PA-39 airplanes only.

When ordering, always specify Part Number, Description and Serial Number of Aircraft



Figure and Index Number	Part Number	Code	NOMENCLATURE	No. Req.	SERIAL NUMBERS AFFECTED
17A-26	83302-67	A	SPRING - Shaft, door locking knob	1	
-27	14843-07	A	BUSHING - Door handle, inside	1	
-28	82732-107	A	BUSHING - Door latch link	4	
-29	480 733	A	PIN - Roll ( 79-012-062-0375)	1	
-30	480 734	A	PIN - Roll ( 79-012-062-0500)	1	
-31	414 781	A	SCREW - (MS24693-C50)	2	
	407 583	A	WASHER - (AN960-8L)	2	
	404 823	A	NUT - (AN363-832)	2	
-32	407 674	A	WASHER - (AN960-C10)	1	
-33	415 543	A	SCREW - (MS35206-253)	1	
	407 610	A	WASHER - (AN960-C8)	3	
	404 823	A	NUT - (AN363-832)	1	
-34	415 495	A	SCREW - (MS35206-230)	2	
	407 582	A	WASHER - (AN960-6L)	2	
	404 971	A	NUT - (AN363-C632)	2	
-35	415 497	A	SCREW - (MS35206-232)	1	
	407 582	A	WASHER - (AN960-6L)	1	
	404 971	A	NUT - (AN363-C632)	1	
-36	25781-00	B	CLIP - Spring	1	
-37	64076-10	A	BUSHING - Baggage door holder rod clevis	2	
-38	414 781	C	SCREW - (MS24693-C50)	2	
	494 004	C	WASHER - ( 8 Finishing)	2	
-39	25595-00	C	STRAP ASSEMBLY - Baggage door pull	1	
-40	25389-00	A	ROD ASSEMBLY - Baggage door holder	1	
-41	24091-02	A	CLEVIS - Baggage door holder rod	1	
-42	25459-00	A	BRACKET - Baggage door holder rod	1	
-43	25595-00	D	STRAP ASSEMBLY - Baggage door pull	1	
-44	414 781	D	SCREW - (MS24693-C50)	2	
	494 004	D	WASHER - ( 8 Finishing)	2	

A - Used on PA-30 with serial numbers 30-853, 30-902 and up, and PA-39 with serial numbers 39-1 and up.  
 B - Used on PA-30 with serial numbers 30-1159, 30-1201 and up, and PA-39 with serial numbers 39-1 and up.  
 C - Used on PA-30 with serial numbers 30-1717, 30-1745 and up, and PA-39 with serial numbers 39-1 and up.  
 D - Used on PA-30 with serial numbers 30-853, 30-902 to 30-1716 inclusive, 30-1718 to 30-1744 inclusive.

When ordering, always specify Part Number, Description and Serial Number of Aircraft

**1 E24**  
INTENTIONALLY LEFT BLANK



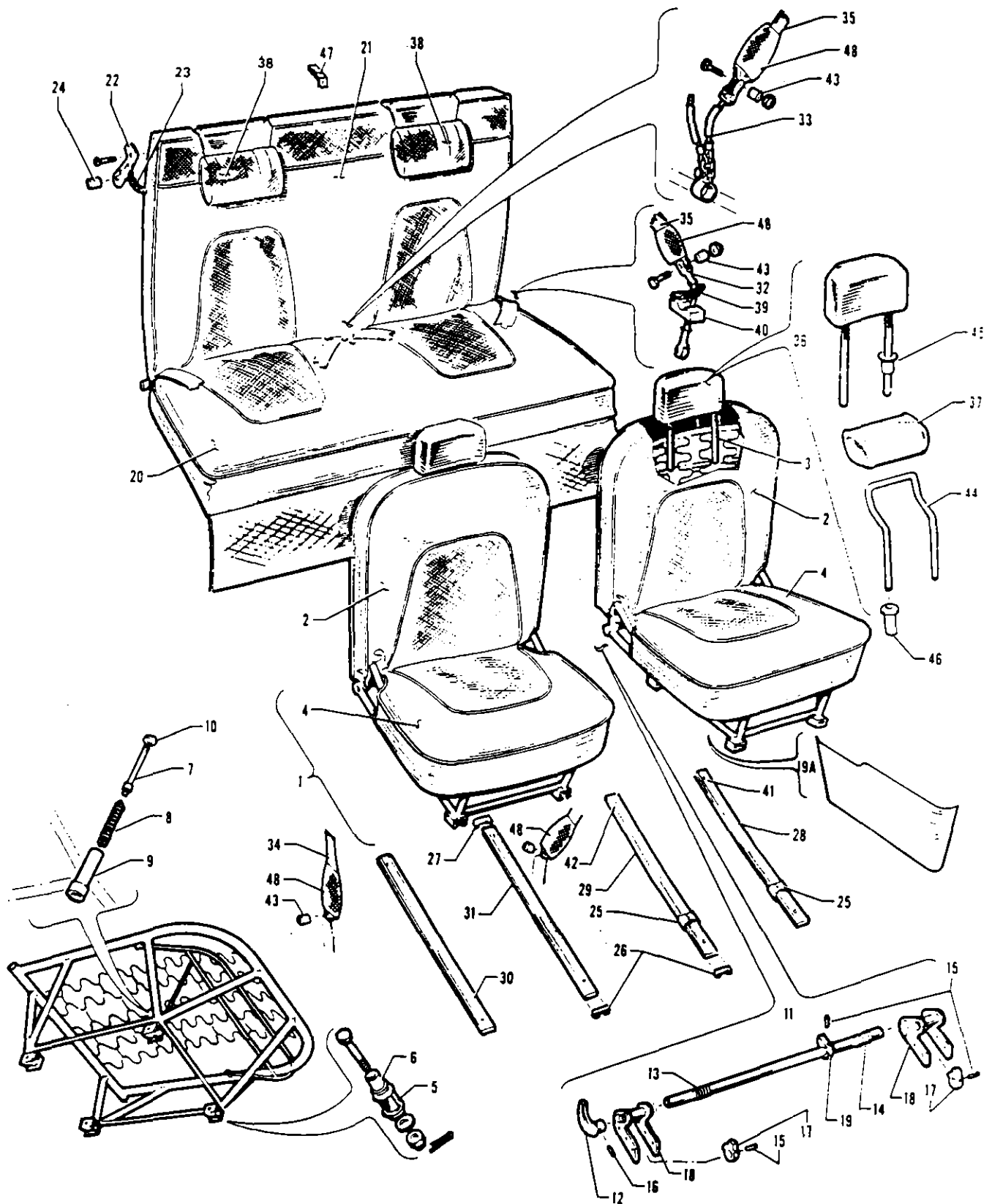

Figure 18. Seats Installation  
(PA-30 with Serial Nos. 30-2 to 30-852, 30-854 to 30-901 inclusive)

SEATS INSTALLATION  
(See Code "A")



SECTION II  
Fuselage Group

Figure and Index Number	Part Number	Code	NOMENCLATURE	No. Req.	SERIAL NUMBERS AFFECTED
18-	23405 25015		DRAWING - Seats Installation DRAWING - Seats Installation		30-2 to 30-589 inclusive 30-590 and up
-1	23090-38 23090-96 23090-46 23090-98 23090-50 23090-102	B	SEAT ASSEMBLY - Front, left, vinyl with cloth insert SEAT ASSEMBLY - Front, left, tan, vinyl with cloth insert SEAT ASSEMBLY - Front, left, vinyl with vinyl insert SEAT ASSEMBLY - Front, left, tan, vinyl with vinyl insert SEAT ASSEMBLY - Front, left, leather with leather insert SEAT ASSEMBLY - Front, left, tan, leather with leather insert	1 1 1 1 1 1	
	23090-58 23090-100	B	SEAT ASSEMBLY - Front, left, leather with cloth insert SEAT ASSEMBLY - Front, left, tan, leather with cloth insert	1 1	
	23090-39 23090-95	B	SEAT ASSEMBLY - Front, right, vinyl with cloth insert SEAT ASSEMBLY - Front, right, tan, vinyl with cloth insert	1 1	
	23090-47 23090-97	B	SEAT ASSEMBLY - Front, right, vinyl with vinyl insert SEAT ASSEMBLY - Front, right, tan, vinyl with vinyl insert	1 1	
	23090-99		SEAT ASSEMBLY - Front, right, tan, leather with cloth insert	1	
	23090-59 23090-101	B	SEAT ASSEMBLY - Front, right, leather with cloth insert SEAT ASSEMBLY - Front, right, tan, leather with leather insert	1 1	
	23090-51	B	SEAT ASSEMBLY - Front, right, leather with leather insert	1	
-2	23090-62	B	CUSHION ASSEMBLY - Front seat back, left, vinyl with cloth insert	1	
	23090-116		CUSHION ASSEMBLY - Front seat back, left, tan, vinyl with cloth insert	1	
	23090-70	B	CUSHION ASSEMBLY - Front seat back, left, vinyl, with vinyl insert	1	
	23090-118		CUSHION ASSEMBLY - Front seat back, left, tan, vinyl with vinyl insert	1	
	23090-78	B	CUSHION ASSEMBLY - Front seat back, left, leather with leather insert	1	
	23090-122		CUSHION ASSEMBLY - Front seat back, left, tan, leather with leather insert	1	
	23090-94	B	CUSHION ASSEMBLY - Front seat back, left, leather with cloth insert	1	
	23090-120		CUSHION ASSEMBLY - Front seat back, left, tan, leather with cloth insert	1	
	23090-63	B	CUSHION ASSEMBLY - Front seat back, right, vinyl with cloth insert	1	
	23090-115		CUSHION ASSEMBLY - Front seat back, right, tan, vinyl with cloth insert	1	
	23090-69	B	CUSHION ASSEMBLY - Front seat back, right, vinyl with vinyl insert	1	
			A - Used on PA-30 with serial numbers 30-2 to 30-852 inclusive, 30-854 to 30-901 inclusive. B - When ordering, specify color red or blue and airplane serial number.		

When ordering, always specify Part Number, Description and Serial Number of Aircraft



Figure and Index Number	Part Number	Code	NOMENCLATURE	No. Req.	SERIAL NUMBERS AFFECTED
18-2	23090-117		CUSHION ASSEMBLY - Front seat back, right, tan, vinyl with vinyl insert	1	
	23090-119		CUSHION ASSEMBLY - Front seat back, right, tan, leather with cloth insert	1	
	23090-93	B	CUSHION ASSEMBLY - Front seat back, right, leather with cloth insert	1	
	23090-121		CUSHION ASSEMBLY - Front seat back, right, tan, leather with leather insert	1	
	23090-79	B	CUSHION ASSEMBLY - Front seat back, right, leather with leather insert	1	
-3	86062-92		TUBE - Seat back frame, headrest	2	
-4	23090-40	B	CUSHION ASSEMBLY - Front seat bottom, left, vinyl with cloth insert	1	
	23090-104		CUSHION ASSEMBLY - Front seat bottom, left, tan, vinyl with cloth insert	1	
	23090-48	B	CUSHION ASSEMBLY - Front seat bottom, left, vinyl with vinyl insert	1	
	23090-106		CUSHION ASSEMBLY - Front seat bottom, left, tan, vinyl with vinyl insert	1	
	23090-52	B	CUSHION ASSEMBLY - Front seat bottom, left, leather with leather insert	1	
	23090-110		CUSHION ASSEMBLY - Front seat bottom, left, tan, leather with leather insert	1	
	23090-60	B	CUSHION ASSEMBLY - Front seat bottom, left, leather with cloth insert	1	
	23090-108		CUSHION ASSEMBLY - Front seat bottom, left, tan, leather with cloth insert	1	
	23090-41	B	CUSHION ASSEMBLY - Front seat bottom, right, vinyl with cloth insert	1	
	23090-103		CUSHION ASSEMBLY - Front seat bottom, right, tan, vinyl with cloth insert	1	
	23090-49	B	CUSHION ASSEMBLY - Front seat bottom, right, vinyl with vinyl insert	1	
	23090-105		CUSHION ASSEMBLY - Front seat bottom, right, tan, vinyl with vinyl insert	1	
	23090-107		CUSHION ASSEMBLY - Front seat bottom, right, tan, leather with cloth insert	1	
	23090-61	B	CUSHION ASSEMBLY - Front seat bottom, right, leather with cloth insert	1	
	23090-109		CUSHION ASSEMBLY - Front seat bottom, right, tan, leather with leather insert	1	
	23090-53	B	CUSHION ASSEMBLY - Front seat bottom, right, leather with leather insert	1	
-5	18968-00		ROLLER - Seat	4	
-6	14175-43		BUSHING - Seat roller	4	
-7	12073-00		PLUNGER ASSEMBLY - Seat	2	
-8	50111-00		SPRING - Seat plunger	2	
-9	86102-56		BUSHING - Seat plunger	2	
-10	85012-30		WASHER - Seat plunger	2	
-11	19392-12		TUBE ASSEMBLY - Reclining mechanism, left	1	
	19392-13		TUBE ASSEMBLY - Reclining mechanism, right	1	

A - Used on PA-30 with serial numbers 30-2 to 30-852 inclusive, 30-854 to 30-901 inclusive.  
B - When ordering, specify color red or blue and airplane serial number.

When ordering, always specify Part Number, Description and Serial Number of Aircraft

SEATS INSTALLATION  
(See Code "A")



SECTION II  
Fuselage Group

Figure and Index Number	Part Number	Code	NOMENCLATURE	No. Req.	SERIAL NUMBERS AFFECTED
18-12	19455-00		HANDLE - Seat back adjustment	1	
-13	19336-00		SPRING - Seat back adjustment, left, inboard	1	
	19336-01		SPRING - Seat back adjustment, right, outboard	1	
-14	19336-00		SPRING - Seat back adjustment, right, inboard	1	
	19336-01		SPRING - Seat back adjustment, left, outboard	1	
-15	480 701		PIN - Roll (#59-028-125-0625)	3	
-16	480 683		PIN - Roll (#59-028-125-0687)	1	
-17	19365-00		CAM - Reclining seat	2	
-18	19359-00		BRACKET ASSEMBLY - Reclining seat	2	
-19	19304-00		STOP - Reclining seat back	1	
-19a	23252-06	B	SKIRT ASSEMBLY - Front seat, vinyl	1	30-2 to 30-263 inclusive
	23252-08	B	SKIRT ASSEMBLY - Front seat, leather	1	30-2 to 30-263 inclusive
	23252-10		SKIRT ASSEMBLY - Front seat, tan, vinyl	1	30-2 to 30-263 inclusive
	23252-12		SKIRT ASSEMBLY - Front seat, tan, leather	1	30-2 to 30-263 inclusive
	24617-02	B	SKIRT ASSEMBLY - Front seat, vinyl, left	1	30-264 and up
	24617-03	B	SKIRT ASSEMBLY - Front seat, vinyl, right	1	30-264 and up
	24617-04	B	SKIRT ASSEMBLY - Front seat, leather, left	1	30-264 and up
	24617-05	B	SKIRT ASSEMBLY - Front seat, leather, right	1	30-264 and up
	24617-06		SKIRT ASSEMBLY - Front seat, tan, vinyl, left	1	30-264 and up
	24617-07		SKIRT ASSEMBLY - Front seat, tan, vinyl, right	1	30-264 and up
	24617-08		SKIRT ASSEMBLY - Front seat, tan, leather, left	1	30-264 and up
	24617-09		SKIRT ASSEMBLY - Front seat, tan, leather, right	1	30-264 and up
-20	23274-18	B	CUSHION ASSEMBLY - Rear seat bottom, vinyl with cloth insert	1	30-2 to 30-589 inclusive
	23274-20		CUSHION ASSEMBLY - Rear seat bottom, tan, vinyl with cloth insert	1	30-2 to 30-589 inclusive
	23274-17	B	CUSHION ASSEMBLY - Rear seat bottom, vinyl with vinyl insert	1	30-2 to 30-589 inclusive
	23274-19		CUSHION ASSEMBLY - Rear seat bottom, tan, vinyl with vinyl insert	1	30-2 to 30-589 inclusive
	23274-14	B	CUSHION ASSEMBLY - Rear seat bottom, leather with cloth insert	1	30-2 to 30-589 inclusive
	23274-16		CUSHION ASSEMBLY - Rear seat bottom, tan, leather with cloth insert	1	30-2 to 30-589 inclusive
	23274-13	B	CUSHION ASSEMBLY - Rear seat bottom, leather with leather insert	1	30-2 to 30-589 inclusive
	23274-15		CUSHION ASSEMBLY - Rear seat bottom, tan, leather with leather insert	1	30-2 to 30-589 inclusive
	25011-00	B	CUSHION ASSEMBLY - Rear seat bottom, leather with leather insert	1	30-590 and up
	25011-03		CUSHION ASSEMBLY - Rear seat bottom, tan, leather with leather insert	1	30-590 and up
	25011-02	B	CUSHION ASSEMBLY - Rear seat bottom, leather with cloth insert	1	30-590 and up
	25011-04		CUSHION ASSEMBLY - Rear seat bottom, tan, leather with leather insert	1	30-590 and up
	25011-05	B	CUSHION ASSEMBLY - Rear seat bottom, vinyl with vinyl insert	1	30-590 and up
	25011-07		CUSHION ASSEMBLY - Rear seat bottom, tan, vinyl with vinyl insert	1	30-590 and up

A - Used on PA-30 with serial numbers 30-2 to 30-852 inclusive, 30-854 to 30-901 inclusive.  
B - When ordering, specify color red or blue and airplane serial number.

When ordering, always specify Part Number, Description and Serial Number of Aircraft



Figure and Index Number	Part Number	Code	NOMENCLATURE	No. Req.	SERIAL NUMBERS AFFECTED
18-20	25011-06	B	CUSHION ASSEMBLY - Rear seat bottom, vinyl with cloth insert	1	30-590 and up
	25011-08		CUSHION ASSEMBLY - Rear seat bottom, tan, vinyl with cloth insert	1	30-590 and up
-21	23275-19	B	CUSHION ASSEMBLY - Rear seat back, vinyl with cloth insert	1	30-2 to 30-589 inclusive
	23275-21		CUSHION ASSEMBLY - Rear seat back, tan, vinyl with cloth insert	1	30-2 to 30-589 inclusive
	23275-18	B	CUSHION ASSEMBLY - Rear seat back, vinyl with vinyl insert	1	30-2 to 30-589 inclusive
	23275-20		CUSHION ASSEMBLY - Rear seat back, tan, vinyl with vinyl insert	1	30-2 to 30-589 inclusive
	23275-15	B	CUSHION ASSEMBLY - Rear seat back, leather with cloth insert	1	30-2 to 30-589 inclusive
	23275-17		CUSHION ASSEMBLY - Rear seat back, tan, leather with cloth insert	1	30-2 to 30-589 inclusive
	23275-14	B	CUSHION ASSEMBLY - Rear seat back, leather with leather insert	1	30-2 to 30-589 inclusive
	23275-16		CUSHION ASSEMBLY - Rear seat back, tan, leather with leather insert	1	30-2 to 30-589 inclusive
	25012-00	B	CUSHION ASSEMBLY - Rear seat back, leather with leather insert	1	30-590 and up
	25012-03		CUSHION ASSEMBLY - Rear seat back, tan, leather with leather insert	1	30-590 and up
	25012-02	B	CUSHION ASSEMBLY - Rear seat back, leather with cloth insert	1	30-590 and up
	25012-04		CUSHION ASSEMBLY - Rear seat back, tan, leather with cloth insert	1	30-590 and up
	25012-05	B	CUSHION ASSEMBLY - Rear seat back, vinyl with vinyl insert	1	30-590 and up
	25012-07		CUSHION ASSEMBLY - Rear seat back, tan, vinyl with vinyl insert	1	30-590 and up
	25012-06	B	CUSHION ASSEMBLY - Rear seat back, vinyl with cloth insert	1	30-590 and up
	25012-08		CUSHION ASSEMBLY - Rear seat back, tan, vinyl with cloth insert	1	30-590 and up
-22	23336-00		BRACKET - Rear seat frame attachment, left	1	30-2 to 30-589 inclusive
	23336-01		BRACKET - Rear seat frame attachment, right	1	30-2 to 30-589 inclusive
-23	42891-00		SPRING - Rear seat attachment	2	30-2 to 30-589 inclusive
-24	14843-32		BUSHING - Rear seat attachment	2	30-2 to 30-589 inclusive
-25	18318-00		STOP - Seat	2	
-26	18842-00		STOP - Seat	2	
-27	18842-02		STOP - Seat	1	
-28	21955-05		TRACK - Seat, left outboard	1	
-29	21955-04		TRACK - Seat, left inboard	1	
-30	21955-03		TRACK - Seat, right outboard	1	
-31	21955-02		TRACK - Seat, right inboard	1	
-32	20868-00		CABLE ASSEMBLY - Safety belt attachment	2	
-33	20869-00		CABLE ASSEMBLY - Safety belt attachment	1	

A - Used on PA-30 with serial numbers 30-2 to 30-852 inclusive, 30-854 to 30-901 inclusive.

B - When ordering, specify color red or blue and airplane serial number.

When ordering, always specify Part Number, Description and Serial Number of Aircraft



Figure and Index Number	Part Number	Code	NOMENCLATURE	No. Req.	SERIAL NUMBERS AFFECTED
18-34	13947-46		BELT ASSEMBLY - Safety, front, brown	2	
	13947-62		BELT ASSEMBLY - Safety, front, red	2	
	13947-68		BELT ASSEMBLY - Safety, front, blue	2	
-35	13947-55		BELT ASSEMBLY - Safety, rear, brown	2	
	13947-59		BELT ASSEMBLY - Safety, rear, red	2	
	13947-65		BELT ASSEMBLY - Safety, rear, blue	2	
-36	19943-27		HEADREST ASSEMBLY - Front, red	2	
	19943-28		HEADREST ASSEMBLY - Front, blue	2	
	19943-29		HEADREST ASSEMBLY - Front, tan	2	
-37	24247-02		HEADREST ASSEMBLY - Front, red	2	
	24247-03		HEADREST ASSEMBLY - Front, blue	2	
	24247-04		HEADREST ASSEMBLY - Front, tan	2	
-38	23469-12		HEADREST ASSEMBLY - Rear, red	2	
	23469-13		HEADREST ASSEMBLY - Rear, blue	2	
	23469-14		HEADREST ASSEMBLY - Rear, tan	2	
-39	20510-00		CLAMP - Rear seat bottom	2	
-40	20517-00		BLOCK - Rear seat support	2	
-41	410 044		SCREW - Seat track (AN509-10R-15)	8	
-42	410 046		SCREW - Seat track (AN509-10R-17)	7	
-43	14843-51		BUSHING - Safety belt	8	
-44	24245-00		FRAME - Headrest	2	
-45	19402-00		BUSHING - Headrest support, 3/4" I. D.	4	
-46	24246-00		BUSHING - Headrest support, 3/8" I. D.	4	
-47	24827-00		STRAP - Rear seat retainer	1	30-590 and up
-48	31186-03		SHROUD ASSEMBLY - Safety belt fitting, front, sand	4	
	31186-04		SHROUD ASSEMBLY - Safety belt fitting, front, red	4	
	31186-05		SHROUD ASSEMBLY - Safety belt fitting, front, blue	4	
	31186-13		SHROUD ASSEMBLY - Safety belt fitting, rear, sand	4	
	31186-14		SHROUD ASSEMBLY - Safety belt fitting, rear, red	4	
	31186-15		SHROUD ASSEMBLY - Safety belt fitting, rear, blue	4	

A - Used on PA-30 with serial numbers 30-2 to 30-852 inclusive, 30-854 to 30-901 inclusive.

When ordering, always specify Part Number, Description and Serial Number of Aircraft

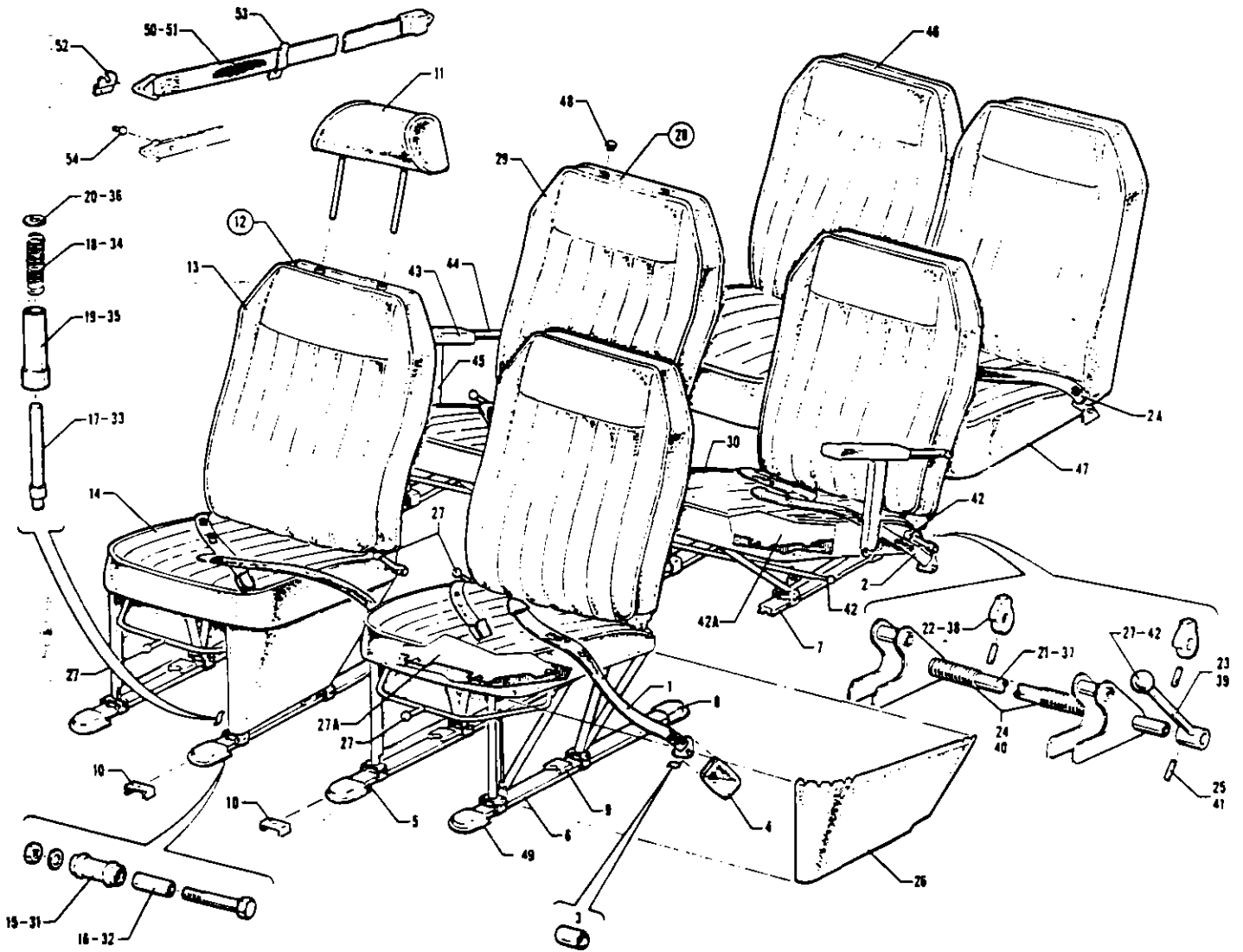

Figure 18A. Seats Installation  
 (PA-30 with Serial Nos. 30-853, 30-902 and up)  
 (PA-39 with Serial Nos. 39-1 and up)

REVISED: FEBRUARY 1977

1F7

Island Enterprises

PA-30  
 PA-39



Figure and Index Number	Part Number	Code	NOMENCLATURE	No. Req.	SERIAL NUMBERS AFFECTED
18A-	25540	C	DRAWING - Seat Installation		
	26652	D	DRAWING - Seat Installation		
	25302	C	DRAWING - Seat Installation (Fifth & Sixth)		
	26602	D	DRAWING - Seat Installation (Fifth & Sixth)		
-1	13947-75	C	BELT ASSEMBLY - Safety, front, red (Friction buckle)	2	
	13947-68	C	BELT ASSEMBLY - Safety, front, blue (Friction buckle)	2	
	13947-46	C	BELT ASSEMBLY - Safety, front, brown (Friction buckle)	2	
	25801-02	C	BELT ASSEMBLY - Safety, front, black (metal to metal buckle)	2	
	25801-03	B	BELT ASSEMBLY - Safety, front, blue (metal to metal buckle)	2	
	25801-04	B	BELT ASSEMBLY - Safety, front, fawn (metal to metal buckle)	2	
	25801-02	B	BELT ASSEMBLY - Safety, front, black (metal to metal buckle)	2	
	-2	13947-89	C	BELT ASSEMBLY - Safety, center, red (friction buckle)	2
13947-88		C	BELT ASSEMBLY - Safety, center, blue (friction buckle)	2	
13947-87		C	BELT ASSEMBLY - Safety, center, brown (friction buckle)	2	
13947-90		C	BELT ASSEMBLY - Safety, center, black (friction buckle)	2	
25801-06		B	BELT ASSEMBLY - Safety, center, blue (metal to metal buckle)	2	
25801-07		B	BELT ASSEMBLY - Safety, center, fawn (metal to metal buckle)	2	
25801-05		B	BELT ASSEMBLY - Safety, center, black (metal to metal buckle)	2	
-2a	13947-76	C	BELT ASSEMBLY - Safety, rear, red (friction buckle)	2	
	13947-65	C	BELT ASSEMBLY - Safety, rear, blue (friction buckle)	2	
	13947-55	C	BELT ASSEMBLY - Safety, rear, brown (friction buckle)	2	
	13947-29	C	BELT ASSEMBLY - Safety, rear, black (friction buckle)	2	
	25801-11		BELT ASSEMBLY - Safety, rear, blue (metal to metal buckle)	2	
	25801-08		BELT ASSEMBLY - Safety, rear, fawn (metal to metal buckle)	2	
-3	25801-10		BELT ASSEMBLY - Safety, rear, black (metal to metal buckle)	2	
	14843-51		BUSHING - Safety belt	12	

A - Used on PA-30 with serial numbers 30-853, 30-902 and up, and PA-39 with serial numbers 39-1 and up.  
 B - Used if shoulder harness has not been installed.  
 C - Used on PA-30 with serial numbers 30-853, 30-902 to 30-1716 inclusive, 30-1718 to 30-1744 inclusive.  
 D - Used on PA-30 with serial numbers 30-1717, 30-1745 and up, and PA-39 with serial numbers 39-1 and up.

When ordering, always specify Part Number, Description and Serial Number of Aircraft



SEATS INSTALLATION  
(See Code "A")



SECTION II  
Fuselage Group

Figure and Index Number	Part Number	Code	NOMENCLATURE	No. Req.	SERIAL NUMBERS AFFECTED
18A-4	25598-03	B	SHROUD ASSEMBLY - Single safety belt fitting, brown	8	
	25598-00	B	SHROUD ASSEMBLY - Single safety belt fitting, red	8	
	25598-21	C	SHROUD ASSEMBLY - Single safety belt fitting, red	8	
	25598-02		SHROUD ASSEMBLY - Single safety belt fitting, blue	8	
	25598-04		SHROUD ASSEMBLY - Single safety belt fitting, gold	8	
	25598-17		SHROUD ASSEMBLY - Single safety belt fitting, black	8	
	25598-25	C	SHROUD ASSEMBLY - Single safety belt fitting, white	8	
	25598-07	B	SHROUD ASSEMBLY - Double safety belt fitting, brown	2	
	25598-05	B	SHROUD ASSEMBLY - Double safety belt fitting, red	2	
	25598-22	C	SHROUD ASSEMBLY - Double safety belt fitting, red	2	
	25598-06		SHROUD ASSEMBLY - Double safety belt fitting, blue	2	
	25598-08		SHROUD ASSEMBLY - Double safety belt fitting, gold	2	
	25598-18		SHROUD ASSEMBLY - Double safety belt fitting, black	2	
	25598-26	C	SHROUD ASSEMBLY - Double safety belt fitting, white	2	
-5	21955-04		TRACK - Front seat, left, inboard	1	
	21955-02		TRACK - Front seat, right, inboard	1	
-6	21955-05		TRACK - Front seat, left, outboard	1	
	21955-03		TRACK - Front seat, right, outboard	1	
-7	25467-00		TRACK - Center seat	4	
-8	25552-00		COVER - Seat track end	8	
-9	18318-00		STOP - Seat	2	
-10	18842-00	B	STOP - Seat	2	
-11	25223-02	B	HEADREST ASSEMBLY - Vinyl, red	4	
	25223-03	B	HEADREST ASSEMBLY - Vinyl, blue	4	
	25223-04	B	HEADREST ASSEMBLY - Vinyl, brown	4	
	25223-24	B	HEADREST ASSEMBLY - Vinyl, black	4	
	25223-48	B	HEADREST ASSEMBLY - Vinyl, gold	4	
	32429-32	C	HEADREST ASSEMBLY - Vinyl, red	4	
	32429-33	C	HEADREST ASSEMBLY - Vinyl, blue	4	
	32429-34	C	HEADREST ASSEMBLY - Vinyl, white	4	
	32429-35	C	HEADREST ASSEMBLY - Vinyl, black	4	
	32429-36	C	HEADREST ASSEMBLY - Vinyl, gold	4	
	25223-12	B	HEADREST ASSEMBLY - Leather, red	4	
	25223-15	B	HEADREST ASSEMBLY - Leather, blue	4	
	25223-18	B	HEADREST ASSEMBLY - Leather, brown	4	
	25223-21	B	HEADREST ASSEMBLY - Leather, gold	4	
	25223-25	B	HEADREST ASSEMBLY - Leather, black	4	
	32429-37	C	HEADREST ASSEMBLY - Leather, red	4	
	32429-38	C	HEADREST ASSEMBLY - Leather, blue	4	
	32429-39	C	HEADREST ASSEMBLY - Leather, white	4	
	32429-40	C	HEADREST ASSEMBLY - Leather, black	4	
	32429-41	C	HEADREST ASSEMBLY - Leather, gold	4	

A - Used on PA-30 with serial numbers 30-853, 30-902 and up, and PA-39 with serial numbers 39-1 and up.  
 B - Used on PA-30 with serial numbers 30-853, 30-902 to 30-1716 inclusive, 30-1718 to 30-1744 inclusive.  
 C - Used on PA-30 with serial numbers 30-1717, 30-1745 and up, and PA-39 with serial numbers 39-1 and up.

When ordering, always specify Part Number, Description and Serial Number of Aircraft



Figure and Index Number	Part Number	Code	NOMENCLATURE	No. Req.	SERIAL NUMBERS AFFECTED
18A-12	25515-02	BF	SEAT ASSEMBLY - Front, left, vinyl	1	
	26617-00	DEG	SEAT ASSEMBLY - Front, left, vinyl	1	
	25515-04	BCF	SEAT ASSEMBLY - Front, left, leather	1	
	26617-02	CDG	SEAT ASSEMBLY - Front, left, leather	1	
	25515-03	BF	SEAT ASSEMBLY - Front, right, vinyl	1	
	26617-01	DEG	SEAT ASSEMBLY - Front, right, vinyl	1	
	25515-05	BCF	SEAT ASSEMBLY - Front, right, leather	1	
	26617-03	CDG	SEAT ASSEMBLY - Front, right, leather	1	
	-13	25515-14	BF	CUSHION ASSEMBLY - Front, back, vinyl	1
26538-21		DEG	CUSHION ASSEMBLY - Front, back, vinyl	1	
25515-15		BCF	CUSHION ASSEMBLY - Front, back, leather	1	
26538-22		CDG	CUSHION ASSEMBLY - Front, back, leather	1	
-14		25515-08	BF	CUSHION ASSEMBLY - Front, bottom, left, vinyl	1
	26574-02	DEG	CUSHION ASSEMBLY - Front, bottom, left, vinyl	1	
	25515-10	BCF	CUSHION ASSEMBLY - Front, bottom, left, leather	1	
	26574-04	CDG	CUSHION ASSEMBLY - Front, bottom, left, leather	1	
	25515-09	BF	CUSHION ASSEMBLY - Front, bottom, right, vinyl	1	
	26574-03	DEG	CUSHION ASSEMBLY - Front, bottom, right, vinyl	1	
	25515-11	BCF	CUSHION ASSEMBLY - Front, bottom, right, leather	1	
	26574-05	CDG	CUSHION ASSEMBLY - Front, bottom, right, leather	1	
-15	18968-00		ROLLER - Seat	4	
-16	41413-38		BUSHING - Seat roller	4	
-17	12073-00		PLUNGER ASSEMBLY - Seat	2	
-18	50111-00		SPRING - Seat plunger	2	
-19	80102-56		BUSHING - Seat plunger	2	
-20	85012-30		WASHER - Seat plunger	2	
-21	25242-02	F	TUBE ASSEMBLY - Reclining mechanism	1	
	26453-05	G	TUBE ASSEMBLY - Reclining mechanism	1	
-22	19365-00		CAM - Reclining seat	2	
-23	25285-00	F	LEVER ASSEMBLY - Seat adjustment	1	
	32380-00	G	HANDLE - Seat adjustment	1	
-24	19336-00		SPRING - Seat back adjustment, inboard	1	
	19336-01		SPRING - Seat back adjustment, outboard	1	
-25	480 701		PIN - Roll (#59-028-125-0625)	3	

Note: Refer to Figure 18B if vertically adjustable front seats are installed.

- A - Used on PA-30 with serial numbers 30-853, 30-902 and up, and PA-39 with serial numbers 39-1 and up.
- B - When ordering, specify color red, blue, brown, gold or black.
- C - When ordering, specify leather or cloth insert.
- D - When ordering, specify color red, blue, white, black or gold.
- E - When ordering, specify vinyl or cloth insert.
- F - Used on PA-30 with serial numbers 30-853, 30-902 to 30-1716 inclusive, 30-1718 to 30-1744 inclusive.
- G - Used on PA-30 with serial numbers 30-1717, 30-1745 and up, and PA-39 with serial numbers 39-1 and up.

When ordering, always specify Part Number, Description and Serial Number of Aircraft



Figure and Index Number	Part Number	Code	NOMENCLATURE	No. Req.	SERIAL NUMBERS AFFECTED
18A-26	25519-04	BF	SKIRT ASSEMBLY - Front seat, vinyl, left	1	
	25519-14	DG	SKIRT ASSEMBLY - Front seat, vinyl, left	1	
	25519-05	BF	SKIRT ASSEMBLY - Front seat, vinyl, right	1	
	25519-15	DG	SKIRT ASSEMBLY - Front seat, vinyl, right	1	
	25519-02	BF	SKIRT ASSEMBLY - Front seat, leather, left	1	
	25519-18	DG	SKIRT ASSEMBLY - Front seat, leather, left	1	
	25519-03	BF	SKIRT ASSEMBLY - Front seat, leather, right	1	
	25519-19	DG	SKIRT ASSEMBLY - Front seat, leather, right	1	
-27	471 093	F	KNOB - ( 222) (3/4") White	2	
	571 109	G	KNOB - ( 214)	1	
-27a	587 600		SUSPENSION - Elastaseat (P-151)	1	
-28	25550-02	BF	SEAT ASSEMBLY - Center, left, vinyl	1	
	26618-00	DEG	SEAT ASSEMBLY - Center, left, vinyl	1	
	25550-04	BCF	SEAT ASSEMBLY - Center, left, leather	1	
	26618-02	CDG	SEAT ASSEMBLY - Center, left, leather	1	
	25550-03	BF	SEAT ASSEMBLY - Center, right, vinyl	1	
	26618-01	DEG	SEAT ASSEMBLY - Center, right, vinyl	1	
	25550-05	BCF	SEAT ASSEMBLY - Center, right, leather	1	
	26618-03	CDG	SEAT ASSEMBLY - Center, right, leather	1	
-29	25550-14	BF	CUSHION ASSEMBLY - Center, back, left, vinyl	1	
	26538-05	DEG	CUSHION ASSEMBLY - Center, back, left, vinyl	1	
	25550-15	BF	CUSHION ASSEMBLY - Center, back, right, vinyl	1	
	26538-06	DEG	CUSHION ASSEMBLY - Center, back, right, vinyl	1	
	25550-16	BCF	CUSHION ASSEMBLY - Center, back, left, leather	1	
	26538-07	CDG	CUSHION ASSEMBLY - Center, back, left, leather	1	
	25550-17	BCF	CUSHION ASSEMBLY - Center, back, right, leather	1	
	26538-08	CDG	CUSHION ASSEMBLY - Center, back, right, leather	1	
-30	25550-08	BF	CUSHION ASSEMBLY - Center, bottom, left, vinyl	1	
	26609-02	DEG	CUSHION ASSEMBLY - Center, bottom, left, vinyl	1	
	25550-09	BF	CUSHION ASSEMBLY - Center, bottom, right, vinyl	1	
	26609-03	DEG	CUSHION ASSEMBLY - Center, bottom, right, vinyl	1	
	25550-10	BCF	CUSHION ASSEMBLY - Center, bottom, left, leather	1	
	26609-04	CDG	CUSHION ASSEMBLY - Center, bottom, left, leather	1	
	25550-11	BCF	CUSHION ASSEMBLY - Center, bottom, right, leather	1	
	26609-05	CDG	CUSHION ASSEMBLY - Center, bottom, right, leather	1	
-31	18968-00		ROLLER - Seat	4	
-32	41413-38		BUSHING - Seat roller	4	
-33	12073-00		PLUNGER ASSEMBLY - Seat	1	
-34	501 11-00		SPRING - Seat plunger	1	
-35	86102-56		BUSHING - Seat plunger	1	
-36	85012-30		WASHER - Seat plunger	1	

Note: Refer to Figure 18B if vertically adjustable front seats are installed.

A - Used on PA-30 with serial numbers 30-853, 30-902 and up, and PA-39 with serial numbers 39-1 and up.

B - When ordering, specify color red, blue, brown, gold or black.

C - When ordering, specify leather or cloth insert.

D - When ordering, specify color red, blue, white, black or gold.

E - When ordering, specify vinyl or cloth insert.

F - Used on PA-30 with serial numbers 30-853, 30-902 to 30-1716 inclusive, 30-1718 to 30-1744 inclusive.

G - Used on PA-30 with serial numbers 30-1717, 30-1745 and up, and PA-39 with serial numbers 39-1 and up.

When ordering, always specify Part Number, Description and Serial Number of Aircraft



Figure and Index Number	Part Number	Code	NOMENCLATURE	No. Req.	SERIAL NUMBER AFFECTED
18A-37	25503-10	F	TUBE ASSEMBLY - Reclining mechanism	1	
	26453-05	G	TUBE ASSEMBLY - Reclining mechanism	1	
-38	19365-00		CAM - Reclining seat	2	
-39	25285-00	F	LEVER ASSEMBLY - Seat adjustment	1	
	32380-00	G	HANDLE - Seat adjustment	1	
-40	19336-00		SPRING - Seat back adjustment, inboard	1	
	19336-01		SPRING - Seat back adjustment, outboard	1	
-41	480 701		PIN - Roll ( 59-028-125-0625)	3	
-42	471 093	F	KNOB - ( 222) (3/4") White	2	
	571 109	G	KNOB - ( 214)	1	
-42a	587 600		SUSPENSION - Elastaseat ( P-151)	1	
-43	25482-04	F	ARMREST ASSEMBLY - Center seat, vinyl, brown	1	
	25482-02	F	ARMREST ASSEMBLY - Center seat, vinyl, red	1	
	25482-12	G	ARMREST ASSEMBLY - Center seat, vinyl, red	1	
	25482-14	G	ARMREST ASSEMBLY - Center seat, leather, red	1	
	25482-03		ARMREST ASSEMBLY - Center seat, vinyl, blue	1	
	25482-16	G	ARMREST ASSEMBLY - Center seat, leather, blue	1	
	25482-18	G	ARMREST ASSEMBLY - Center seat, vinyl, gold	1	
	25482-05		ARMREST ASSEMBLY - Center seat, leather, gold	1	
	25482-10		ARMREST ASSEMBLY - Center seat, vinyl, black	1	
	25482-20	G	ARMREST ASSEMBLY - Center seat, leather, black	1	
-44	25454-00		TUBE ASSEMBLY - Armrest	1	
-45	25453-00		BRACKET - Armrest support	1	
-46	25535-02	BF	CUSHION ASSEMBLY - Seat back, rear, vinyl	2	
	26584-02	DEG	CUSHION ASSEMBLY - Seat back, rear, vinyl	2	
	25535-03	BF	CUSHION ASSEMBLY - Seat back, rear, leather	2	
	26584-03	CDG	CUSHION ASSEMBLY - Seat back, rear, leather	2	
	25535-23	BF	CUSHION ASSEMBLY - Seat back, rear, leather (cloth insert)	2	
-47	25534-02	BF	CUSHION ASSEMBLY - Seat bottom, rear, vinyl	2	
	26591-02	DEG	CUSHION ASSEMBLY - Seat bottom, rear, vinyl	2	
	25534-03	BF	CUSHION ASSEMBLY - Seat bottom, rear, leather	2	
	26591-03	CDG	CUSHION ASSEMBLY - Seat bottom, rear, leather	2	
	25534-18	BF	CUSHION ASSEMBLY - Seat bottom, rear, leather (cloth insert)	2	
-48	453 661		PLUG BUTTON - Seat back	8	
-49	25552-03	G	COVER - Seat track	4	

A - Used on PA-30 with serial numbers 30-853, 30-902 and up, and PA-39 with serial numbers 39-1 and up.  
 B - When ordering, specify color red, blue, brown, gold or black.  
 C - When ordering, specify leather or cloth insert.  
 D - When ordering, specify color red, blue, white, black or gold.  
 E - When ordering, specify vinyl or cloth insert.  
 F - Used on PA-30 with serial numbers 30-853, 30-902 to 30-1716 inclusive, 30-1718 to 30-1744 inclusive.  
 G - Used on PA-30 with serial numbers 30-1717, 30-1745 and up, and PA-39 with serial numbers 39-1 and up.

When ordering, always specify Part Number, Description and Serial Number of Aircraft

PIPER PARTS CATALOG

Figure and Index Number	Part Number	Code	NOMENCLATURE	No. Req.	SERIAL NUMBERS AFFECTED
18A-50	43813-07	Z	HARNESS ASSEMBLY - Shoulder, front, black	2	
	43813-08	Z	HARNESS ASSEMBLY - Shoulder, front, blue	2	
	43813-06	Z	HARNESS ASSEMBLY - Shoulder, front, fawn	2	
	54536-06	Z	HARNESS ASSEMBLY - Shoulder, inertia reel, front, black	2	
-51	43813-04	Z	HARNESS ASSEMBLY - Shoulder, center, black	2	
	43813-05	Z	HARNESS ASSEMBLY - Shoulder, center, blue	2	
	43813-03	Z	HARNESS ASSEMBLY - Shoulder, center, fawn	2	
	54536-02	Z	HARNESS ASSEMBLY - Shoulder, inertia reel, center, black	2	
-52	44514-00	Z	CATCH - Shoulder harness retainer, left	2	39-1 to 39-134 inclusive
	44514-01	Z	CATCH - Shoulder harness retainer, right	2	39-1 to 39-134 inclusive
-53	44512-00	Z	CLIP - Shoulder harness retainer	3	
	27252-00	BZ	CLIP ASSEMBLY - Shoulder harness retainer, right front	1	
-54	487 560		STUD - (XX-10369-12)	4	39-135 and up

A - Used on PA-30 with serial numbers 30-853, 30-902 and up, and PA-39 with serial numbers 39-1 and up.  
 B - When ordering, specify color beige or white.  
 Z - Used on PA-39 airplanes only.

When ordering, always specify Part Number, Description and Serial Number of Aircraft

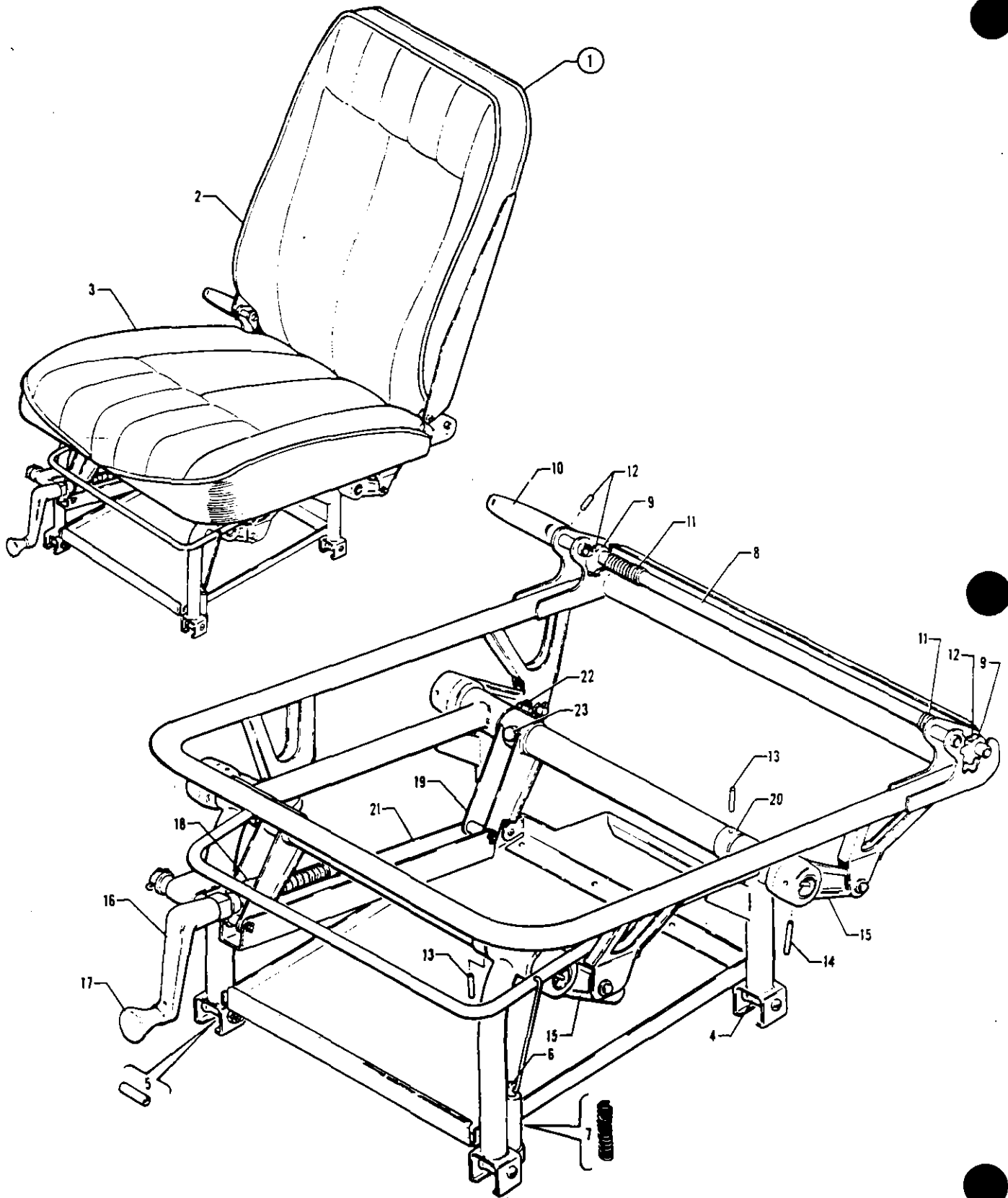

Figure 18B. Vertically Adjustable Seats Installation  
 (PA-30 with Serial Nos. 30-1717, 30-1745 and up)  
 (PA-39 with Serial Nos. 39-1 and up)

PIPER PARTS CATALOG

Figure and Index Number	Part Number	Code	NOMENCLATURE	No. Req.	SERIAL NUMBERS AFFECTED
18B-	26971		DRAWING - Vertically Adjustable Seat Installation		
-1	26617-04	BE	SEAT ASSEMBLY - Left, vinyl	1	
	26617-05	BE	SEAT ASSEMBLY - Right, vinyl	1	
	26617-06	CE	SEAT ASSEMBLY - Left, leather	1	
	26617-07	CE	SEAT ASSEMBLY - Right, leather	1	
-2	26538-21	BE	* CUSHION ASSEMBLY - Back, vinyl	1	
	26538-22	CE	* CUSHION ASSEMBLY - Back, leather	1	
-3	26970-02	BE	* CUSHION ASSEMBLY - Bottom, left, vinyl	1	
	26970-03	BE	* CUSHION ASSEMBLY - Bottom, right, vinyl	1	
	26970-04	CE	* CUSHION ASSEMBLY - Bottom, left, leather	1	
	26970-05	CE	* CUSHION ASSEMBLY - Bottom, right, leather	1	
-4	18968-00		* * ROLLER - Seat (with one center bushing)	4	
	452 386	D	* * ROLLER - Seat (with two end bushings)	4	
-5	14175-43		* * BUSHING - Seat roller, center	4	
	63900-54	D	* * BUSHING - Seat roller, ends	8	
-6	12073-00		* * PLUNGER ASSEMBLY - Seat	2	
-7	50111-00		* * SPRING - Seat plunger	2	
-8	26453-05		* * TUBE ASSEMBLY - Reclining mechanism	1	
-9	19365-00		* * * CAM - Reclining seat	2	
-10	32380-00		* * HANDLE - Seat back adjustment	1	
-11	19336-00		* * SPRING - Seat back adjustment, inboard	1	
	19336-01		* * SPRING - Seat back adjustment, outboard	1	
-12	480 701		* * PIN - Roll (59-028-125-0625)	3	
-13	480 727	D	* * PIN - Roll (52-028-125-1000)	2	
-14	480 690	D	* * PIN - Roll (52-040-187-1250)	12	
-15	27018-00	D	* * ARM - Seat adjusting	4	
-16	26653-00	D	* * HANDLE ASSEMBLY - Seat vertical adjustment	1	
-17	571 131	D	* * * KNOB - (KN678-1)	1	
-18	26951-00	D	* * * BLOCK - Seat adjustment	1	
-19	26965-00	D	* * ANGLE ASSEMBLY - Seat adjustment	2	
-20	26953-00	D	* * BUSHING - Seat	2	
-21	26961-00	D	* * CHANNEL - Seat adjustment	1	
-22	27244-00		* BOLT - Special	1	
	27245-00		* WASHER - Special	1	
	407 565		* WASHER - (AN960-416)	3	
	404 888		* NUT - (MS20365-428C)	1	
-23	401 315		* BOLT - (AN4-15A)	1	
	27245-00		* WASHER - Special	4	
	404 888		* NUT - (MS20365-428C)	1	

- A - Used on PA-30 with serial numbers 30-1717, 30-1745 and up, and PA-39 with serial numbers 39-1 and up
- B - When ordering, specify vinyl or cloth insert.
- C - When ordering, specify leather or cloth insert.
- D - These parts must be ordered from Service Spares Department, Piper Aircraft, Vero Beach, Florida.
- E - When ordering, specify color red, blue, white, black or gold.

When ordering, always specify Part Number, Description and Serial Number of Aircraft

**1F16**  
**INTENTIONALLY LEFT BLANK**



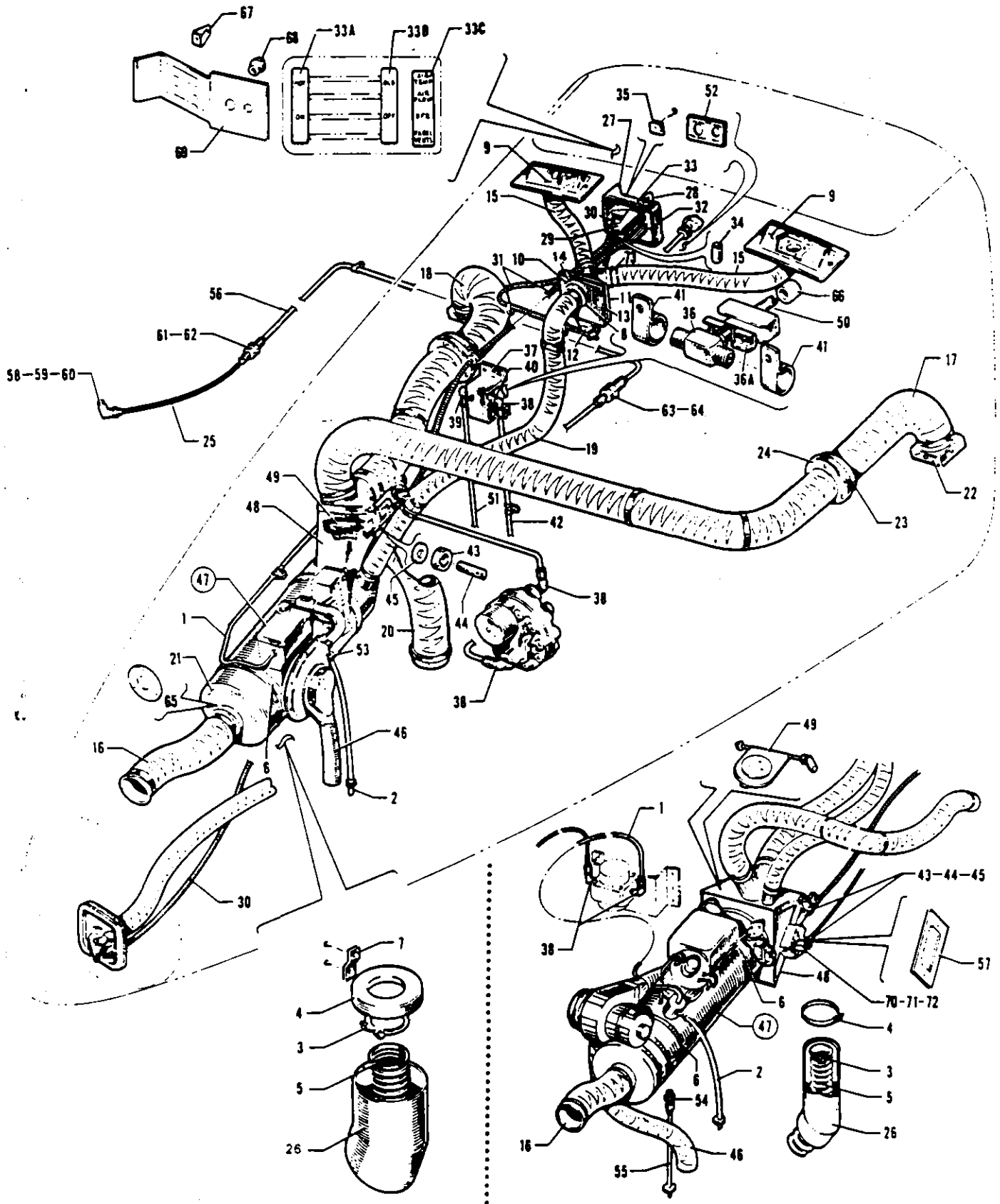

Figure 19. Heater and Defroster System



Figure and Index Number	Part Number	Code	NOMENCLATURE	No. Req.	SERIAL NUMBERS AFFECTED
19-	23770 24728 26721	Y C A	DRAWING - Heater and Defroster Installation DRAWING - Heater and Defroster Installation DRAWING - Heater and Defroster Installation		30-2 to 30-401 inclusive
-1	11987-63 11987-71	Y YZ	TUBE ASSEMBLY TUBE ASSEMBLY	1 1	30-2 to 30-401 inclusive 30-402 and up, 39-1 and up
-2	13586-19 22369-24	Y YZ	TUBE - Plastic TUBE - Plastic	1 1	30-2 to 30-401 inclusive 30-402 and up, 39-1 and up
-3	17860-00		CLAMP ASSEMBLY - Heater exhaust	1	
-4	17862-02 454 848	Y YZ	RING - Heater exhaust shroud mounting CLAMP - Heater exhaust shroud mounting (#E-45)	1 1	30-2 to 30-401 inclusive 30-402 and up, 39-1 and up
-5	18794-02 30670-02 30670-03	Y CE A	TUBE - Heater exhaust TUBE - Heater exhaust TUBE - Heater exhaust	1 1 1	30-2 to 30-401 inclusive
-6	30679-00		CLAMP - Heater	2	
-7	18996-00	Y	STRAP - Heater shroud tie	1	30-2 to 30-401 inclusive
-8	19513-32		WASHER - Rubber	1	
-9	22295-00		OUTLET - Defroster air	2	
-10	22363-00		VALVE ASSEMBLY - Defroster	1	
-11	22353-00		TUBE ASSEMBLY - Defroster air outlet	1	
-12	22354-00		VALVE - Defroster air outlet	1	
-13	21574-00		SPACER - Defroster air valve	1	
-14	22352-00		PLATE ASSEMBLY - Defroster air outlet	1	
-15	22374-02 22374-03		HOSE ASSEMBLY - Defroster air outlet, LH HOSE ASSEMBLY - Defroster air outlet, RH	1 1	
-16	22502-27		HOSE - Air inlet	1	
-17	22502-28		HOSE - Heat outlet, left	1	
-18	22502-29		HOSE - Heat outlet, right	1	
-19	22502-30		HOSE - Defroster	1	
-20	22502-31	Y	HOSE - Heater dump	1	30-2 to 30-401 inclusive
-21	23694-00	BY	TUBE ASSEMBLY - Heater air intake	1	30-2 to 30-401 inclusive
-22	23705-00	D	TUBE ASSEMBLY - Cabin hot air inlet	2	
-23	23733-00		RING - Heater duct seal	2	
-24	23734-00		PLATE - Heater duct seal ring	2	
-25	23745-02		HOSE ASSEMBLY - Flexible	1	
-26	23747-00 24672-00	Y YZ	SHROUD ASSEMBLY - Heater exhaust SHROUD ASSEMBLY - Heater exhaust	1 1	30-2 to 30-401 inclusive 30-402 and up, 39-1 and up

A - Used on PA-30 with serial numbers 30-1717, 30-1745 and up, and PA-39 with serial numbers 39-1 and up.  
 B - See Figure 20B for PA-30 with serial numbers 30-402 and up, and PA-39 with serial numbers 39-1 and up.  
 C - Used on PA-30 with serial numbers 30-402 to 30-1716 inclusive, 30-1718 to 30-1744 inclusive.  
 D - Used on PA-30 with serial numbers 30-2 to 30-1716 inclusive, 30-1718 to 30-1744 inclusive.  
 E - Order part for PA-30 with serial numbers 30-1717, 30-1745 and up if Heater Modification Kit 760 249 is installed.  
 Y - Used on PA-30 airplanes only.  
 Z - Used on PA-39 airplanes only.

When ordering, always specify Part Number, Description and Serial Number of Aircraft



Figure and Index Number	Part Number	Code	NOMENCLATURE	No. Req.	SERIAL NUMBERS AFFECTED
19-27	23760-00	AY	CONTROLS ASSEMBLY - Cabin air	1	30-2 to 30-176 inclusive
	24456-00	Y	CONTROLS ASSEMBLY - Cabin air	1	30-177 to 30-401 inclusive
	24730-00	D	CONTROLS ASSEMBLY - Cabin air	1	
	26744-00	B	CONTROLS ASSEMBLY - Cabin air	1	
-28	22287-00	Y	KNOB ASSEMBLY - Control	2	30-2 to 30-176 inclusive
	22287-00	Y	KNOB ASSEMBLY - Control	3	30-177 to 30-401 inclusive
	22287-00	D	KNOB ASSEMBLY - Control	4	
-29	22433-00	Y	ARM ASSEMBLY - Control cable actuator	2	30-2 to 30-176 inclusive
	22433-00	Y	ARM ASSEMBLY - Control cable actuator	3	30-177 to 30-401 inclusive
	22433-00	YZ	ARM ASSEMBLY - Control cable actuator	4	30-402 and up, 39-1 and up
-30	22470-06		WIRE - Control, 43" L	2	
	22470-07		WIRE - Control, 82" L	1	
	22470-12	CD	WIRE - Control, 44 1/2" L	1	
	22470-15	B	WIRE - Control, 52" L	1	
-31	22472-06		HOUSING - Control wire, 35" L	1	
	22472-08		HOUSING - Control wire, 38" L	1	
	22472-09		HOUSING - Control wire, 77" L	1	
	22472-15	CD	HOUSING - Control wire, 39 1/2" L	1	
	22472-20	B	HOUSING - Control wire, 47" L	1	
-32	22460-00		PLATE - Cabin air control guide	1	
-33	23759-00	AY	PLATE - Cabin air control cover	1	30-2 to 30-176 inclusive
	24452-00	Y	PLATE - Cabin air control cover	1	30-177 to 30-401 inclusive
	24727-00	D	PLATE - Cabin air control cover	1	
-33a	24949-00	E	PLACARD - Heater control, left	1	
-33b	24950-00	E	PLACARD - Heater control, center	1	
-33c	24951-00	E	PLACARD - Heater control, right	1	
-34	61402-00	AY	BUSHING - Control arm spacer	2	30-2 to 30-176 inclusive
	61402-24	Y	BUSHING - Control arm spacer	2	30-177 to 30-401 inclusive
	61402-24	YZ	BUSHING - Control arm spacer	3	30-402 and up, 39-1 and up
-35	454 887		CLAMP - Control cable	4	
-36	19460-00		HEATER - Shutoff cock	1	
-36a	757 575		STEM ASSEMBLY - Heater shutoff valve (19460-02)	1	
-37	23872-00	F	BRACKET - Heater fuel valve mounting	1	
	23872-02	B	BRACKET - Heater fuel valve mounting	1	
-38	455 872		ELBOW - 90° (ANS22-2D)	3	
-39	455 893		ELBOW - 90° (ANS22-3D)	1	
-40	455 174		COUPLING - (W. H. 330 x 2)	2	
-41	454 885	F	CLAMP	2	
	454 934	B	CLAMP	2	

A - If Kit 756 776 has been installed, order part for PA-30 with serial numbers 30-177 to 30-401 inclusive.  
 B - Used on PA-30 with serial numbers 30-1717, 30-1745 and up, and PA-39 with serial numbers 39-1 and up.  
 C - Order part for PA-30 with serial numbers 30-1717, 30-1745 and up if Heater Modification Kit 760 249 is installed.  
 D - Used on PA-30 with serial numbers 30-402 to 30-1716 inclusive, 30-1718 to 30-1744 inclusive.  
 E - Used on PA-30 with serial numbers 30-594 to 30-1716 inclusive, 30-1718 to 30-1744 inclusive.  
 F - Used on PA-30 with serial numbers 30-2 to 30-1716 inclusive, 30-1718 to 30-1744 inclusive.  
 Y - Used on PA-30 airplanes only.  
 Z - Used on PA-39 airplanes only.

When ordering, always specify Part Number, Description and Serial Number of Aircraft



Figure and Index Number	Part Number	Code	NOMENCLATURE	No. Req	SERIAL NUMBERS AFFECTED
19-42	23766-00		LINE ASSEMBLY - Heater	1	
-43	70371-02		FITTING - Fuel shutoff swivel	2	
-44	70371-03		STUD - Fuel shutoff swivel	2	
-45	81342-19		WASHER	2	
-46	85052-37	Y	HOSE - Combustion air inlet	1	30-2 to 30-401 inclusive
	85052-39	YZ	HOSE - Combustion air inlet	1	30-402 and up, 39-1 and up
-47	464 346	FY	HEATER ASSEMBLY - (Stewart-Warner)	1	30-2 to 30-401 inclusive
	751 959	EYZ	HEATER ASSEMBLY - (Janitrol)	1	30-402 and up, 39-1 and up
-48	24255-00	Y	BOX ASSEMBLY - Air distribution	1	30-2 to 30-401 inclusive
	24726-00	YZ	BOX ASSEMBLY - Air distribution	1	30-402 and up, 39-1 and up
-49	24252-00	Y	VALVE ASSEMBLY - Air distribution box	1	30-2 to 30-401 inclusive
	24673-00	YZ	VALVE ASSEMBLY - Air distribution box	1	30-402 and up, 39-1 and up
-50	23882-00	B	TUBE ASSEMBLY - Heater fuel valve control	1	
	26375-00	D	TUBE ASSEMBLY - Heater fuel valve control	1	
-51	11987-67		TUBE ASSEMBLY	1	
-52	24151-00	Y	PLACARD - Cabin heat	1	30-2 to 30-401 inclusive
	24729-00	A	PLACARD - Cabin heat	1	
-53	451 857	Y	ADAPTER - (AN840-4D)	1	30-2 to 30-401 inclusive
-54	476 686	YZ	NIPPLE - (AN816-4)	1	30-402 and up, 39-1 and up
-55	11987-69	YZ	TUBE ASSEMBLY - Drain	1	30-402 and up, 39-1 and up
-56	23752-01		LINE ASSEMBLY	1	
-57	24671-00	YZ	GASKET - Heater switch assembly	1	30-402 and up, 39-1 and up
-58	458 877	Y	ELBOW - (AN822-3)	1	30-2 to 30-401 inclusive
	25095-00	YZ	ELBOW - Special	1	30-402 and up, 39-1 and up
-59	477 629	YZ	NUT - (AN924-4)	1	30-402 and up, 39-1 and up
-60	462 058	YZ	GASKET - (MS29512-4)	1	30-402 and up, 39-1 and up
-61	491 067	Y	UNION - (AN832-3)	1	30-2 to 30-401 inclusive
	458 937	YZ	ELBOW - (AN837-3)	1	30-402 and up, 39-1 and up
-62	477 628		NUT - (AN924-3)	1	
-63	477 617		NUT - (AN924-3D)	1	
-64	491 059		UNION - (AN832-3D)	1	
-65	26570-00	CD	PLATE - Heater vent air restrictor	1	
-66	14175-114	D	BUSHING - Heater fuel valve control	1	
-67	22287-00	G	KNOB ASSEMBLY - Control	4	
	66980-00		KNOB ASSEMBLY - Control (571 132)	4	39-146 and up
-68	571 113	D	KNOB - Heater fuel valve control (106D)	1	
-69	26517-00	D	PLACARD - Heater control	1	
-70	70371-02	CD	FITTING - Heater switch	1	
-71	70371-03	CD	STUD - Heater switch	1	
-72	81342-19	CD	WASHER	1	
-73	454 860		CLAMP - (H1-1800)	2	

A - Used on PA-30 with serial numbers 30-402 to 30-1716 inclusive, 30-1718 to 30-1744 inclusive.  
 B - Used on PA-30 with serial numbers 30-2 to 30-1716 inclusive, 30-1718 to 30-1744 inclusive.  
 C - Used on PA-30 with serial numbers 30-402 to 30-1716 inclusive, 30-1718 to 30-1744 inclusive if Heater Modification Kit 760 249 has been installed.  
 D - Used on PA-30 with serial numbers 30-1717, 30-1745 and up, and PA-39 with serial numbers 39-1 and up.  
 E - See Figures 20A and 20B for component parts.  
 F - See Figure 20 for component parts.  
 G - Used on PA-30 with serial numbers 30-1717, 30-1745 and up, and PA-39 with serial numbers 39-1 to 39-145  
 Y - Used on PA-30 airplanes only.  
 Z - Used on PA-39 airplanes only.

When ordering, always specify Part Number, Description and Serial Number of Aircraft

**1 F21**

**INTENTIONALLY LEFT BLANK**

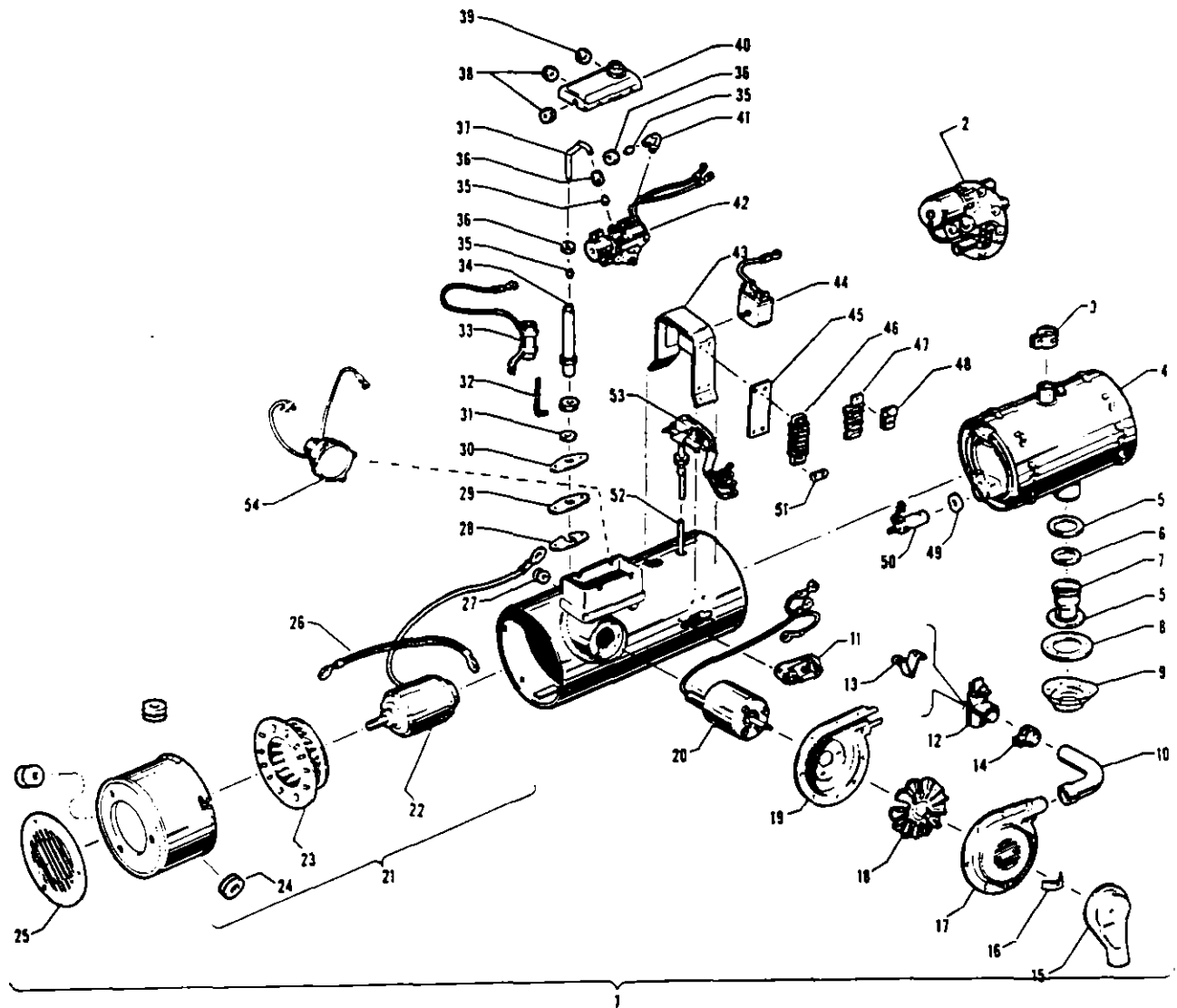

Figure 20. Stewart - Warner Heater Assembly



Figure and Index Number	Part Number	Code	NOMENCLATURE	No. Req.	SERIAL NUMBERS AFFECTED
20-1	464 346		HEATER ASSEMBLY - (Model 940-DC12)	1	
-2	753 116		VALVE - Safety (G 719 553)	1	
-3	751 548		CLAMP - Hose, combustion air (489 408)	1	
-4	754 710		EXCHANGE ASSEMBLY - Heat (G 711 237)	1	
-5	753 168		WASHER - Exhaust (486 803)	2	
-6	752 839		PACKING - "O" Ring (486 802)	1	
-7	754 708		EXTENSION - Exhaust (486 238)	1	
-8	751 852		GASKET - Exhaust tube (711 241)	1	
-9	751 235		ADAPTER - Exhaust tube (711 240)	1	
-10	753 005		TUBE - Combustion air blower (700 137)	1	
-11	756 151		SWITCH - Cycling duct limit (700 587)	1	
-12	751 751		FUSE ASSEMBLY - Thermal (700 580)	1	
-13	751 775		FUSE LINK - Thermal (700 578)	1	
-14	751 548		CLAMP - Hose, combustion air (489 408)	1	
-15	751 231		ADAPTER ASSEMBLY - (G 711 229)	1	
-16	751 431		BRACKET - Combustion air blower (489 491)	1	
-17	751 934		HOUSING - Combustion air blower, outer (711 234)	1	
-18	751 776		WHEEL - Combustion air blower (G 484 046)	1	
-19	751 933		HOUSING - Combustion air blower, inner (489 811)	1	
-20	752 417		MOTOR - Combustion air blower (G 700 141)	1	
-21	751 397		BLOWER ASSEMBLY - Vent air (G 700 177)	1	
-22	752 416		MOTOR - Vent air blower (489 620)	1	
-23	753 169		FAN - Vent air blower (G 488 932)	1	
-24	756 100		SHOCK MOUNT - Vent air blower (700 146)	3	
-25	752 315		COVER - Louvered, vent air inlet (711 235)	1	
-26	752 313		LEAD - Ground (486 216)	1	
-27	751 849		GROMMET - (475 127)	1	
-28	752 773		PLATE - Tapping (711 223)	1	
-29	751 851		GASKET - Fuel line (711 222)	1	
-30	751 782		FLANGE - Fuel line (711 224)	1	
-31	752 772		PACKING - "O" Ring (711 098)	1	
-32	751 546		CABLE - Knit (474 948)	1	
-33	752 824		RESISTOR - (489 851)	1	
-34	751 432		BUSHING ASSEMBLY - Tube (G 711 231)	1	
-35	752 971		SLEEVE - Fuel line (91427)	3	
-36	751 545		COUPLING - Fuel line (91426)	3	
-37	753 006		TUBE - Fuel line (711 221)	1	
-38	751 850		GROMMET - (711 215)	2	
-39	751 854		GROMMET - (473 455)	1	
-40	751 550		COVER ASSEMBLY - Fuel valve (711 217)	1	
-41	754 707		ELBOW - Fuel line (475 318)	1	
-42	753 123		VALVE - Fuel control (G 720 082-5)	1	
-43	751 853		GUARD ASSEMBLY - Switch (G 711 244)	1	
-44	752 933		RELAY ASSEMBLY - (721 176)	1	
-45	756 153		STRIP - Double market (486 327)	1	
-46	756 154		STRIP - Thermal (486 326)	1	
-47	752 974		STRIP - Connector (484 955)	1	
-48	751 547		CLAMP - Cable (484 986)	1	
-49	751 832		GASKET - Igniter (475 067)	1	
-50	752 044		IGNITER ASSEMBLY - (G 474 942)	1	
-51	752 126		JUMPER - Terminal (485 152)	1	
-52	752 840		ROD - Quartz (486 901)	1	
-53	756 102		SWITCH - Flame detector (700 592)	1	
-54	756 197		SWITCH - Lockout over heat (719831-1)	1	

When ordering, always specify Part Number, Description and Serial Number of Aircraft

**1F24**  
INTENTIONALLY LEFT BLANK



# PIPER PARTS CATALOG

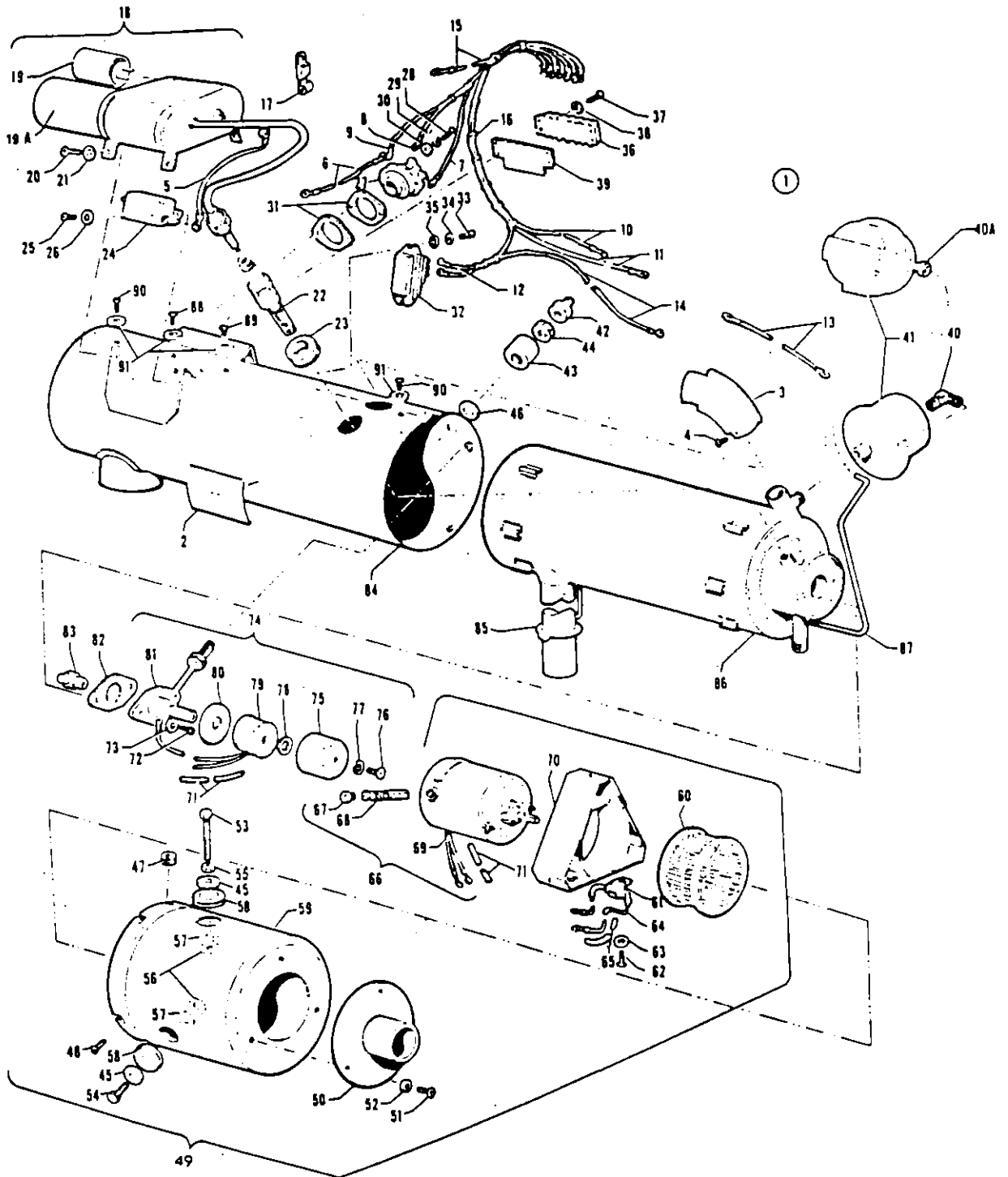

Figure 20A. Janitrol Heater Assembly

REVISED: MAY 1980

1G1

PA-30  
PA-39

PIPER PARTS CATALOG

Figure and Index Number	Part Number	Code	NOMENCLATURE	No. Req.	SERIAL NUMBER AFFECTED
20A-1	751 959		HEATER ASSEMBLY	1	
-2			* PLATE - Identification	1	
-3	751 258		* ADAPTER - Elbow	1	
-4			* SCREW - (AN530-6R6)	1	
-5			* WIRE ASSEMBLY - Ignition to filter	1	
-6			* WIRE ASSEMBLY - Blower ground	1	
-7			* WIRE ASSEMBLY - Heater ground	1	
-8			* WIRE ASSEMBLY - Terminal 1 to overheat switch	1	
-9			* WIRE ASSEMBLY - Terminal 2 to ignition filter	1	
-10			* WIRE ASSEMBLY - Terminal 6 to blower filter	1	
-11			* WIRE ASSEMBLY - Terminal 2 to pressure switch	1	
-12			* WIRE ASSEMBLY - Terminal 3 to cycle switch	1	
-13			* WIRE ASSEMBLY - Pressure switch to overheat switch	1	
-14			* WIRE ASSEMBLY - Cycle switch to fuel valve	1	
-15			* WIRE ASSEMBLY - Terminal 1 to combustion air blower	1	
-16			* TIE - Cable	15	
-17			* STRAP - Cable	4	
-18	752 108		* IGNITION ASSEMBLY	1	
-19	756 577	A	* * VIBRATOR - Ignition (solid state)	1	
-19a	757 982		* * COIL - Ignition	1	
-20	415 753		* SCREW - (AN545-8R7)	4	
-21	407 134		* WASHER - (AN936A8)	4	
-22	756 180		* PLUG - Spark	1	
-23	434 139		* GROMMET - (AN931-10-20) (MS35489-18)	1	
-24	751 801		* FILTER - Radio noise	1	
-25	415 751		* SCREW - (AN515-8R5)	2	
-26	407 134		* WASHER - (AN936A8)	2	
-27	756 177		* SWITCH - Limit	1	
-28	415 754		* SCREW - (AN515-8R8)	2	
-29	407 134		* WASHER - (AN936A8)	2	
-30	417 563		* WASHER - (AN960-8)	2	
-31	751 874		* GASKET - Limit switch	2	
-32	756 178		* SWITCH - Cycling	1	
-33	415 754		* SCREW - (AN515-8R8)	2	
-34	407 134		* WASHER - (AN936A8)	2	
-35	407 563		* WASHER - (AN960-8)	2	
-36	753 049		* STRIP - Terminal	1	
-37	415 755		* SCREW - (AN515-8R10)	2	
-38	407 134		* WASHER - (AN936A8)	2	
-39	752 107		* INSULATOR - Terminal strip	1	
-40	754 758		* ELBOW - Pressure switch (for 1/8" O. D. line)	1	
	754 771		* ELBOW - Pressure switch (for 3/16" O. D. line)	1	
-40a	757 987		* CONNECTOR - Pressure switch (for 1/8" O. D. line)	1	
	757 970		* CONNECTOR - Pressure switch (for 3/16" O. D. line)	1	
			<p>A - Before ordering new ignition vibrator, ascertain ignition assembly part number stamped on ignition assembly cover. If Janitrol No. D08D50 is stamped on ignition assembly cover, order new ignition assembly P/N 752 108 as a replacement. If Janitrol No. 81D12-5 or 81D12-5M, 92D12-4 or 92D12-4M, or 91E12-4 is stamped on ignition assembly cover, order ignition vibrator P/N 756 577 only.</p>		

When ordering, always specify Part Number, Description and Serial Number of Aircraft

PIPER PARTS CATALOG

Figure and Index Number	Part Number	Code	NOMENCLATURE	No. Req.	SERIAL NUMBERS AFFECTED
20A-41	756 179	A	* SWITCH - Pressure (with pressure ports on switch cylinder ends)	1	
	757 756		* SWITCH - Pressure (with pressure ports on switch cylinder sides)	1	
-42	753 390		* BUSHING - (AN894-4-2)	1	
-43	756 183		* SHROUD - Fuel fitting	1	
-44	477 629		* NUT - (AN924-4)	1	
-45	753 200		* WASHER - Flat	3	
-46			* GASKET - (AN900-8)	1	
-47			* GROMMET - (MS35489-35)	1	
-48			* SCREW	4	
-49	753 662		* BLOWER ASSEMBLY - Vent air	1	
-50	751 257		* * ADAPTER	1	
-51	415 751		* * SCREW - (AN515-8R5)	3	
-52	407 134		* * WASHER - (AN936A8)	3	
-53	756 181		* * SCREW - Machine	1	
-54	756 182		* * SCREW - Machine	2	
-55			* * NUT - (AN335-4)	1	
-56	753 199		* * WASHER - Flat	3	
-57			* * WASHER	3	
-58	751 875		* * GROMMET - (MS35489-8)	3	
-59	751 960		* * HOUSING - Blower	1	
-60	753 201		* * FAN - Vent air blower	1	
-61	753 899		* * CAPACITOR ASSEMBLY	1	
-62	415 752		* * SCREW - (AN515-8R6)	1	
-63	407 134		* * WASHER - (AN936A8)	1	
-64			* * WIRE ASSEMBLY - Blower ground	1	
-65	762 451		* * SLEEVE - High temperature	1	
-66	753 663		* * MOTOR ASSEMBLY - Vent air blower	1	
-67	753 392		* * * CAP - Brush assembly	2	
-68	753 391		* * * BRUSH ASSEMBLY - Motor	2	
-69			* * * TERMINAL	1	
-70	753 389		* * BRACKET ASSEMBLY - Motor	1	
-71	762 452		* SLEEVE - High temperature	3	
-72	415 753		* SCREW - (AN515-8R7)	2	
-73	407 103		* WASHER - (AN935-8)	2	
-74	751 802		* FUEL FEED. NOZZLE HOLDER AND VALVE ASSEMBLY	1	
-75	753 900		* * COVER - Solenoid	1	
-76	415 752		* * SCREW - (AN515-8R6)	1	
-77	407 103		* * WASHER - (AN935-8)	1	
-78	755 865		* * PACKING - "O" Ring	1	
-79	753 901		* * COIL ASSEMBLY - Solenoid	1	
-80	755 864		* * PLATE - Solenoid base	1	
-81	753 121		* * VALVE ASSEMBLY - Fuel	1	
-82	751 876		* GASKET - Valve assembly	1	
-83	752 498		* NOZZLE - Fuel spray	1	
-84	752 127		* JACKET ASSEMBLY	1	
-85	751 877		* GASKET - Asbestos	1	
-86	753 048		* TUBE - Combustion	1	
-87	760 522		* KIT - Negative pressure line	1	
-88			* SCREW - (AN515-8R4)	1	
-89	415 751		* SCREW - (AN515-8R5)	1	
-90	415 752		* SCREW - (AN515-8R6)	2	
-91	407 134		* WASHER - (AN936A8)	4	

A - Not available. Order switch P/N 757 756. Also secure connector P/N 757 987 if 1/8" O. D. negative pressure line is installed or connector P/N 757 970 if 3/16" O. D. negative pressure line is installed.

When ordering, always specify Part Number, Description and Serial Number of Aircraft

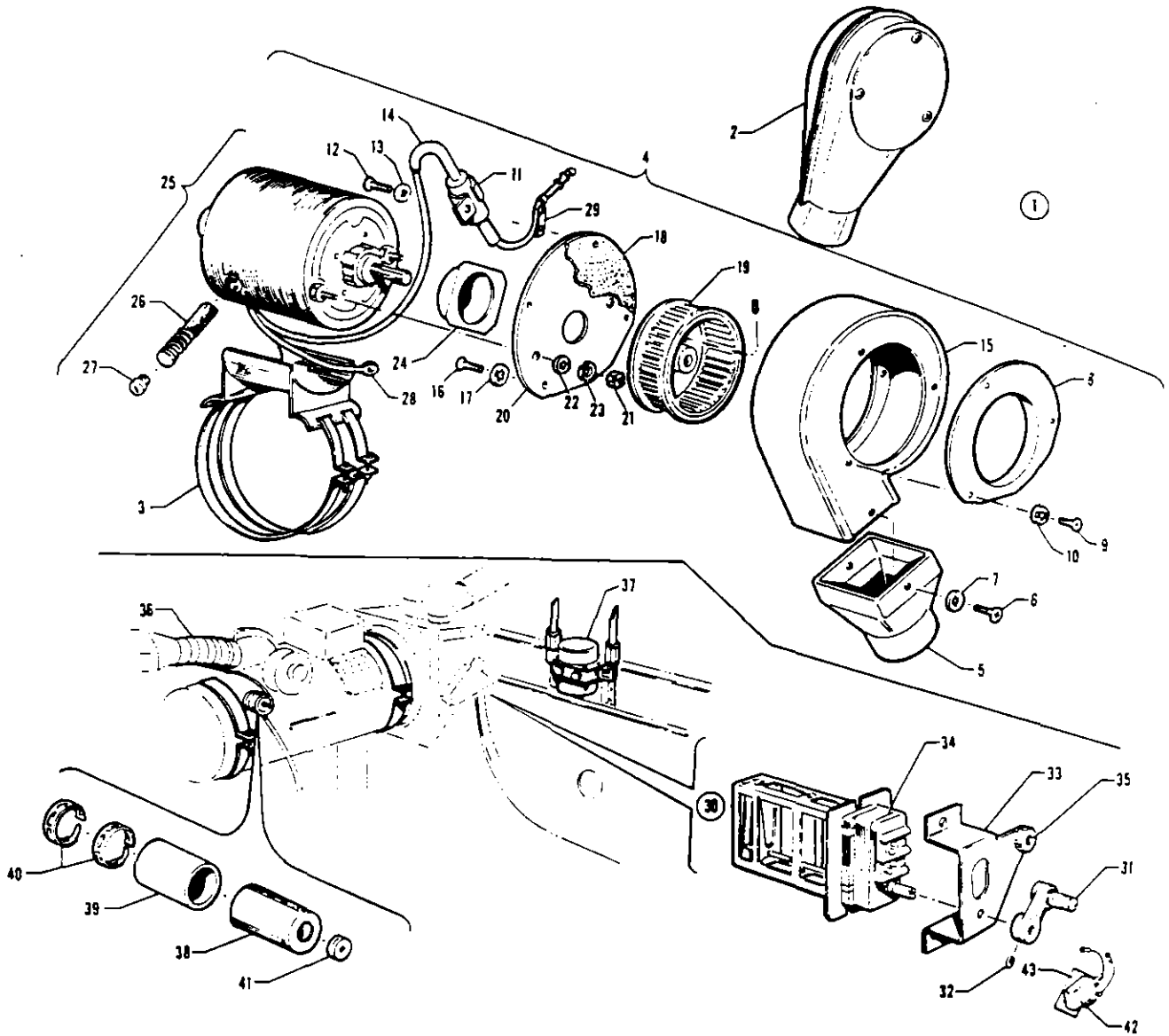

Figure 20B. Janitrol Heater Components

PIPER PARTS CATALOG

Figure and Index Number	Part Number	Code	NOMENCLATURE	No. Req.	SERIAL NUMBERS AFFECTED
20B-1	753 905		COMBUSTION AIR BLOWER AND MOTOR ASSEMBLY	1	
-2	752 109		* ADAPTER ASSEMBLY - Blower inlet	1	
-3	753 664		* MOUNT - Combustion air blower support	1	
-4	753 902		* COMBUSTION AIR BLOWER AND MOTOR	1	
-5	751 259		* * ADAPTER - Outlet	1	
-6			* * SCREW - (AN530-6R6)	2	
-7	407 133		* * WASHER - (AN936A6)	2	
-8	751 803		* * FLANGE - Inlet	1	
-9			* * SCREW - (AN530-6R6)	3	
-10	407 133		* * WASHER - (AN936A6)	3	
-11	753 899		* * CAPACITOR	1	
-12			* * SCREW - (AN530-6R6)	1	
-13	407 133		* * WASHER - (AN936A6)	1	
-14	762 451		* * SLEEVE - High temperature	1	
-15	751 961		* * HOUSING - Blower	1	
-16			* * SCREW - (AN530-6R6)	3	
-17	407 133		* * WASHER - (AN936A6)	3	
-18	751 878		* * GASKET - Back plate	1	
-19	753 202		* * FAN - Combustion air blower	1	
-20	755 866		* * PLATE - Back	1	
-21			* * NUT - (AN345-10)	2	
-22	407 584		* * WASHER - (AN960-10L)	2	
-23	407 128		* * WASHER - (AN936-310)	2	
-24	756 184		* * SPACER	1	
-25	753 663		* * MOTOR ASSEMBLY - Combustion air blower	1	
-26	753 391		* * * BRUSH ASSEMBLY	2	
-27	753 392		* * * CAP - Brush assembly	2	
-28			* * * TERMINAL - Preinsulated	1	
-29			* * STRAP - Cable	1	
-30	756 185	AC	SWITCH ASSEMBLY - Adjustable duct	1	
	757 573	B	SWITCH ASSEMBLY - Adjustable duct	1	
-31	752 341	AC	* LEVER ASSEMBLY - Switch	1	
	752 367	B	* LEVER ASSEMBLY - Switch	1	
-32			* SCREW - (AN565D8H3)	1	
-33	753 903	AC	* BRACKET - Switch	1	
	758 127	B	* BRACKET - Switch	1	
-34	756 240	AC	* SWITCH - Adjustable duct	1	
	756 262	B	* SWITCH - Adjustable duct	1	
-35			* SPACER	1	

A - Used on PA-30 with serial numbers 30-402 to 30-1716 inclusive, 30-1718 to 30-1744 inclusive.  
 B - Used on PA-30 with serial numbers 30-1717, 30-1745 and up, and PA-39 with serial numbers 39-1 and up.  
 C - Order part for PA-30 with serial numbers 30-1717, 30-1745 and up if Heater Modification Kit 760 249 has been installed.

When ordering, always specify Part Number, Description and Serial Number of Aircraft



Figure and Index Number	Part Number	Code	NOMENCLATURE	No. Req.	SERIAL NUMBERS AFFECTED
20B-36	753 050		TUBE - Flexible	1	
-37	753 122		FUEL REGULATOR AND SHUTOFF VALVE	1	
-38	756 187		SHROUD - Fuel fitting	1	
-39	751 962		HOSE - Fuel fitting shroud	1	
-40	753 904		CLAMP - Hose	2	
-41	434 129		GROMMET - (AN931-2-9)	1	
-42	487 940	AB	SWITCH - Micro (#MS25253-2)	1	
-43	60054-40	AB	BLOCK - Micro switch	1	
<p>A - Used on PA-30 with serial numbers 30-1717, 30-1745 and up, and PA-39 with serial numbers 39-1 and up.                      B - Used on PA-30 with serial numbers 30-402 to 30-1716 inclusive, 30-1718 to 30-1744 inclusive if Heater Modification Kit 760 249 has been installed.</p>					

When ordering, always specify Part Number, Description and Serial Number of Aircraft

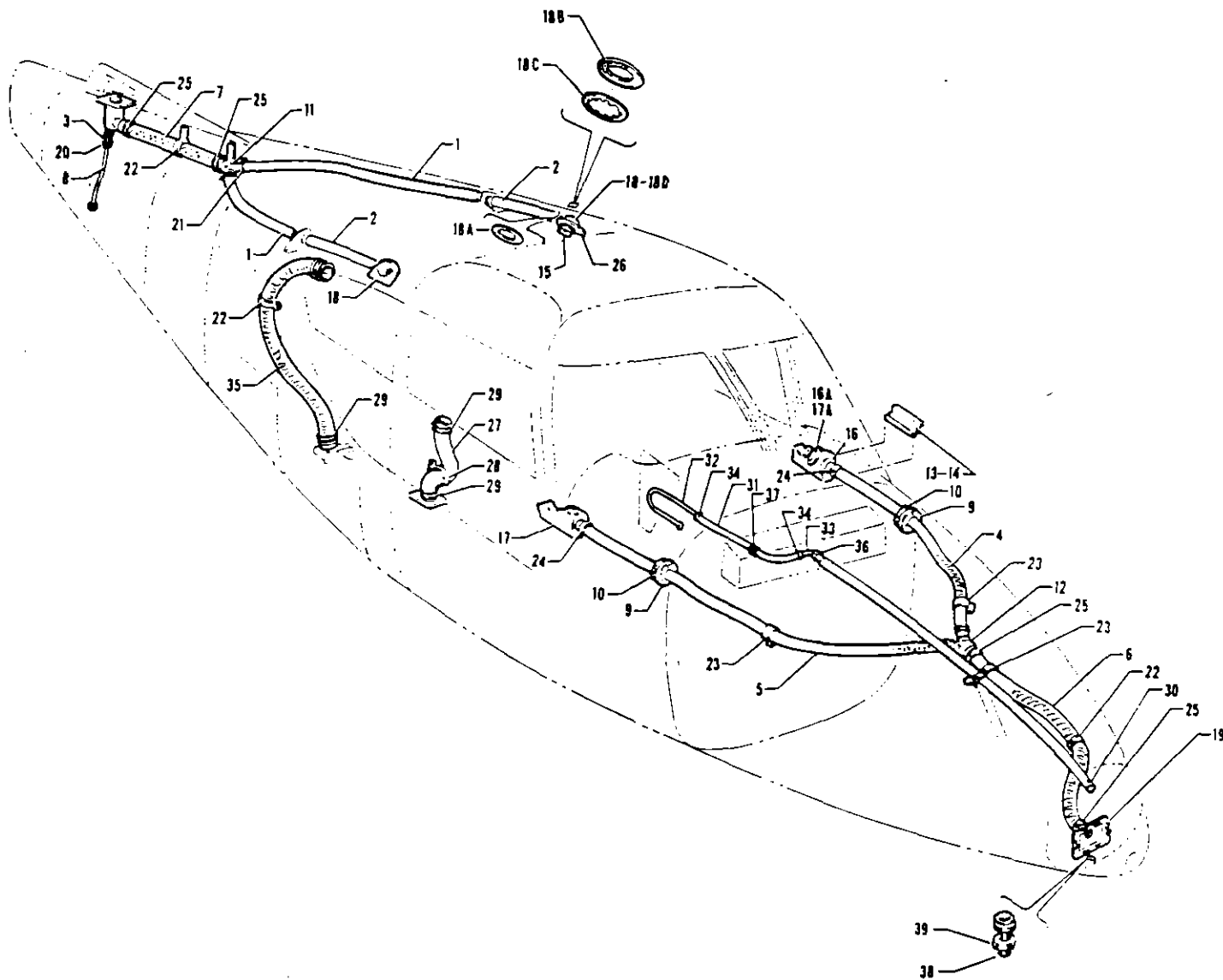

Figure 21. Ventilating System



Figure and Index Number	Part Number	Code	NOMENCLATURE	No. Req.	SERIAL NUMBERS AFFECTED
21-	24300 25387 24203	B E	DRAWING - System Installation, Cabin Ventilating DRAWING - System Installation, Cabin Ventilating DRAWING - Tube Installation, Radio Cooling		
-1	13586-70 22369-28	B E	TUBE - Cabin air distribution (50" L) TUBE - Cabin air distribution (67" L)	2 2	
-2	13586-76	B	TUBE - Cabin air distribution (18 1/2" L)	2	
-3	16633-37		HOSE - Drain, air box	1	
-4	22502-30		HOSE - Cabin air distribution	1	
-5	22502-39		HOSE - Cabin air distribution	1	
-6	22502-40		HOSE - Cabin air distribution	1	
-7	22502-41		HOSE - Cabin air distribution	1	
-8	23339-04		TUBE - Drain, air box	1	
-9	24220-00		PLATE - Ventilator duct seal ring	2	
-10	24222-00		RING - Ventilator duct seal ring	2	
-11	24272-00		TUBE ASSEMBLY - Cabin air distribution	1	
-12	24273-00		TUBE ASSEMBLY - Cabin air distribution	1	
-13	24284-00	A	PLATE - Air outlet, left	1	
-14	24285-00	A	PLATE - Air outlet, right	1	
-15	24298-02	B	COVER - Air valve, charcoal	2	
	24298-03	B	COVER - Air valve, brown	2	
-16	24307-00	B	BOX ASSEMBLY - Air outlet, left, charcoal	1	
	24307-02	Y	BOX ASSEMBLY - Air outlet, left, brown	1	30-2 to 30-1042 inclusive
	25574-00	C	BOX ASSEMBLY - Air outlet, left, beige	1	
	26613-00	F	BOX ASSEMBLY - Air outlet, left, beige	1	
	26613-02	F	BOX ASSEMBLY - Air outlet, left, white	1	
-16a	492 082	Y	VALVE ASSEMBLY - Cabin air outlet box	1	30-2 to 30-1042 inclusive
	462 006	C	GASPER ASSEMBLY - Cabin air outlet box	1	
	26569-00	F	VALVE ASSEMBLY - Cabin air outlet box	1	
-17	24308-00		BOX ASSEMBLY - Air outlet, right, charcoal	1	30-2 to 30-1042 inclusive
	24308-02		BOX ASSEMBLY - Air outlet, right, brown	1	30-2 to 30-1042 inclusive
	25580-00	C	BOX ASSEMBLY - Air outlet, right, beige	1	
	26630-00	F	BOX ASSEMBLY - Air outlet, right, beige	1	
	26630-02	F	BOX ASSEMBLY - Air outlet, right, white	1	
-17a	492 082	Y	VALVE ASSEMBLY - Cabin air outlet box	1	30-2 to 30-1042 inclusive
	462 006	C	GASPER ASSEMBLY - Cabin air outlet box	1	
	26569-00	F	VALVE ASSEMBLY - Cabin air outlet box	1	
-18	24323-00	B	VALVE ASSEMBLY - Cabin air outlet	2	
	25573-00	D	VALVE ASSEMBLY - Cabin air outlet (gasper type)	2	
	26448-00	F	VALVE ASSEMBLY - Cabin air outlet (complete)	2	

A - Used on PA-30 with serial numbers 30-2 to 30-1716 inclusive, 30-1718 to 30-1744 inclusive.  
 B - Used on PA-30 with serial numbers 30-2 to 30-852 inclusive, 30-854 to 30-901 inclusive.  
 C - Used on PA-30 with serial numbers 30-1043 to 30-1716 inclusive, 30-1718 to 30-1744 inclusive.  
 D - Used on PA-30 with serial numbers 30-853, 30-902 to 30-1716 inclusive, 30-1718 to 30-1744 inclusive.  
 E - Used on PA-30 with serial numbers 30-853, 30-902 and up, and PA-39 with serial numbers 39-1 and up.  
 F - Used on PA-30 with serial numbers 30-1717, 30-1745 and up, and PA-39 with serial numbers 39-1 and up.  
 Y - Used on PA-30 airplanes only.

When ordering, always specify Part Number, Description and Serial Number of Aircraft





Figure and Index Number	Part Number	Code	NOMENCLATURE	No. Req.	SERIAL NUMBERS AFFECTED
21-18a	24290-00	Y	RING - Retainer	1	30-2 to 30-501 inclusive
	24737-00	Y	RING - Retainer	1	30-504 to 30-852 inclusive, 30-854 to 30-901 inclusive
	25571-00	C	PLATE - Retainer	1	
	26432-00	D	PLATE - Air valve	1	
-18b	31429-00	A	WASHER - Air valve	1	
-18c	19513-75	A	SEAL - Air valve	1	
	25572-00	C	GASKET - Air valve	1	
-18d	26569-00	D	VALVE ASSEMBLY - Cabin air	1	
-19	24242-00	BY	PLATE ASSEMBLY - Air intake hose	1	30-2 to 30-176 inclusive
	24451-00	YZ	PLATE ASSEMBLY - Air intake hose	1	30-177 and up, 39-1 and up
-20	454 983		CLAMP - Hose (SAE #8) Type E	2	
-21	454 805		CLAMP - Hose (SAE #16) Type E	2	
-22	487 666		STRAP ASSEMBLY - (#668-3-12DR)	3	
-23	487 665		STRAP ASSEMBLY - (#668-16-16DR)	3	
-24	454 859		CLAMP - Hose (#A3122-22-1)	4	
-25	454 912		CLAMP - Hose (#A3122-34-1)	4	
-26	19871-00	A	GASKET - Air box	2	
-27	10525-100	A	HOSE	1	
-28	80032-44	A	CLAMP - Hose	1	
-29	454 864		CLAMP - Hose (#H3-1800)	2	
-30	13586-70		HOSE - Radio cooling (50" L)	1	
-31	82371-92		HOSE - Radio cooling (17" L)	1	
-32	26996-00		TUBE - Radio cooling	1	
-33	24196-00		TUBE ASSEMBLY - Radio cooling	1	
-34	454 987		CLAMP - Radio cooling (SAE #12)	2	
-35	22502-20	YZ	HOSE - Cabin air exhaust	1	30-853, 30-902 and up, 39-1 and up
-36	16268-06		GROMMET	1	
-37	434 140		GROMMET - (AN931-12-20)	1	
-38	70371-02		FITTING - Fresh air valve swivel	1	
-39	70371-03		STUD - Fresh air valve swivel	1	

A - Used on PA-30 with serial numbers 30-2 to 30-852 inclusive, 30-854 to 30-901 inclusive.  
 B - If Kit 756 776 has been installed, order part for PA-30 with serial numbers 30-177 and up.  
 C - Used on PA-30 with serial numbers 30-853, 30-902 to 30-1716 inclusive, 30-1718 to 30-1744 inclusive.  
 D - Used on PA-30 with serial numbers 30-1717, 30-1745 and up, and PA-39 with serial numbers 39-1 and up.

When ordering, always specify Part Number, Description and Serial Number of Aircraft

**1G10**  
INTENTIONALLY LEFT BLANK

PIPER PARTS CATALOG

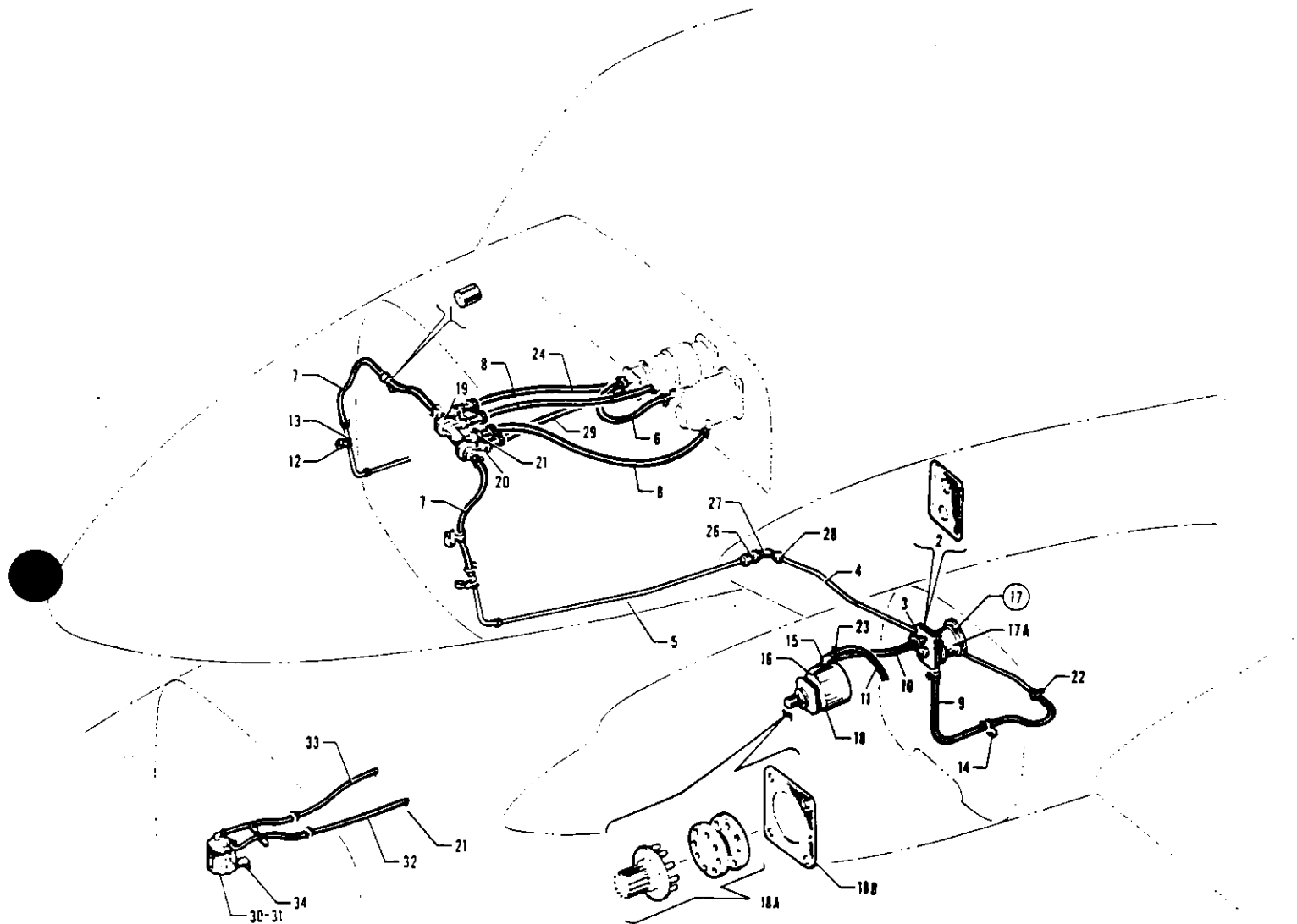

Figure 22. Vacuum System Installation

REVISED: MAY 1980

1G11

Island Enterprises

PA-30  
PA-39

PIPER PARTS CATALOG

Figure and Index Number	Part Number	Code	NOMENCLATURE	No. Req.	SERIAL NUMBERS AFFECTED
22-	23846	C	DRAWING - Vacuum System Installation		
	26701	D	DRAWING - Vacuum System Installation		
-1	14976-66		BUSHING	1	
-2	19892-00		PLATE - Vacuum regulating valve	2	
-3	19893-00		GASKET - Vacuum regulating valve	2	
-4	23838-00		LINE ASSEMBLY - Vacuum, LH	1	
	23838-01		LINE ASSEMBLY - Vacuum, RH	1	
-5	23841-00		LINE ASSEMBLY - Vacuum, LH	1	
	23841-01		LINE ASSEMBLY - Vacuum, RH	1	
-6	61541-16	Y	HOSE - Flexible (18" length)	1	30-2 to 30-1400 inclusive
	16633-70	B	HOSE - Flexible (47" length)	1	
	16633-94	D	HOSE - Flexible (23" length)	1	
-7	61541-18		HOSE - Flexible, LH	1	
	61541-19		HOSE - Flexible, RH	1	
-8	61541-20	C	HOSE - Flexible, LH	1	
	61541-48	C	HOSE - Flexible, RH	1	
	39998-03	D	HOSE - Flexible	2	
-9	16633-33		HOSE - Flexible	2	
-10	82371-69		HOSE - Flexible	2	
-11	82371-54		HOSE - Flexible	2	
-12	454 940		CLAMP - Hose clamp attachment	3	
-13	454 933		CLAMP - Hose (#A4980S-8-91)	2	
-14	454 868		CLAMP - Hose (#A3046S-12-91)	4	
-15	458 958		ELBOW - (#1K1-6-10)	2	
-16	558 901		ELBOW - (AN833-6D)	2	
-17	492 066		REGULATING VALVE	2	
-17a	751 815		* FILTER - Regulating valve (#B3-5-1)	1	
-18	481 683	Y	DRY VACUUM PUMP - (#113A8)	2	30-2 to 30-309 inclusive
	481 692	Y	DRY VACUUM PUMP - (#200CC)	2	30-310 and up
	481 692	Z	DRY VACUUM PUMP - (#200CC) Left	1	39-1 and up
	26749-05	EZ	DRY VACUUM PUMP - (#200CW) Right	1	39-1 and up
-18a	753 910	A	* COUPLING ASSEMBLY KIT - Vacuum pump drive (No. 350)	1	
-18b	751 859		* * GASKET - Vacuum pump mounting (B3-1-2)	1	
-19	492 079		CHECK VALVE AND MANIFOLD ASSEMBLY	1	
-20	454 943		CLAMP - Hose #8	6	
-21	454 832		CLAMP - Hose #10	8	
-22	454 987		CLAMP - Hose #12	10	
-23	554 802		CLAMP - Hose #14	4	

- A - Used on Vacuum Pumps 481 692 (#200CC) and 26749-05 (#200CW) only.
- B - Used on PA-30 with serial numbers 30-1401 to 30-1716 inclusive, 30-1718 to 30-1744 inclusive.
- C - Used on PA-30 with serial numbers 30-2 to 30-1716 inclusive, 30-1718 to 30-1744 inclusive.
- D - Used on PA-30 with serial numbers 30-1717, 30-1745 and up, and PA-39 with serial numbers 39-1 and up.
- E - Used on PA-30 with counter-rotating right engine.
- Y - Used on PA-30 airplanes only.
- Z - Used on PA-39 airplanes only.

When ordering, always specify Part Number, Description and Serial Number of Aircraft



Figure and Index Number	Part Number	Code	NOMENCLATURE	No. Req.	SERIAL NUMBERS AFFECTED
22-24	61541-17	Y	HOSE - Flexible (19 1/2" length)	1	30-2 to 30-1400 inclusive
	16633-71	C	HOSE - Flexible (50" length)	1	
	16633-36	B	HOSE - Flexible (20 1/2" length)	1	
-25	458 914	Y	ELBOW - (AN837-8D)	2	30-2 to 30-19 inclusive
-26	477 621	Y	NUT - (AN924-8D)	2	30-2 to 30-19 inclusive
-27	82371-28	YZ	HOSE - Flexible	2	30-20 and up, 39-1 and up
-28	454 987	YZ	CLAMP - Hose 12	4	30-20 and up, 39-1 and up
-29	61541-25	Y	HOSE - Flexible (21 1/2" length)	1	30-2 to 30-1400 inclusive
	16633-71	C	HOSE - Flexible (50" length)	1	
	16633-36	B	HOSE - Flexible (20 1/2" length)	1	
-30	460 888		FILTER ASSEMBLY - Air (66673-00)	1	
-31	757 899		CARTRIDGE - Air filter (D9-18-1)	1	
-32	61541-49	A	HOSE - Gyro horizon to filter	1	
	39998-03	B	HOSE - Gyro horizon to filter	1	
-33	61541-39	A	HOSE - Directional gyro to filter	1	
	39998-03	B	HOSE - Directional gyro to filter	1	
-34	25047-00		BRACKET - Gyro filter attachment	1	

A - Used on PA-30 with serial numbers 30-2 to 30-1716 inclusive, 30-1718 to 30-1744 inclusive.  
 B - Used on PA-30 with serial numbers 30-1717, 30-1745 and up, and PA-39 with serial numbers 39-1 and up.  
 C - Used on PA-30 with serial numbers 30-1401 to 30-1716 inclusive, 30-1718 to 30-1744 inclusive.  
 Y - Used on PA-30 airplanes only.  
 Z - Used on PA-39 airplanes only.

When ordering, always specify Part Number, Description and Serial Number of Aircraft

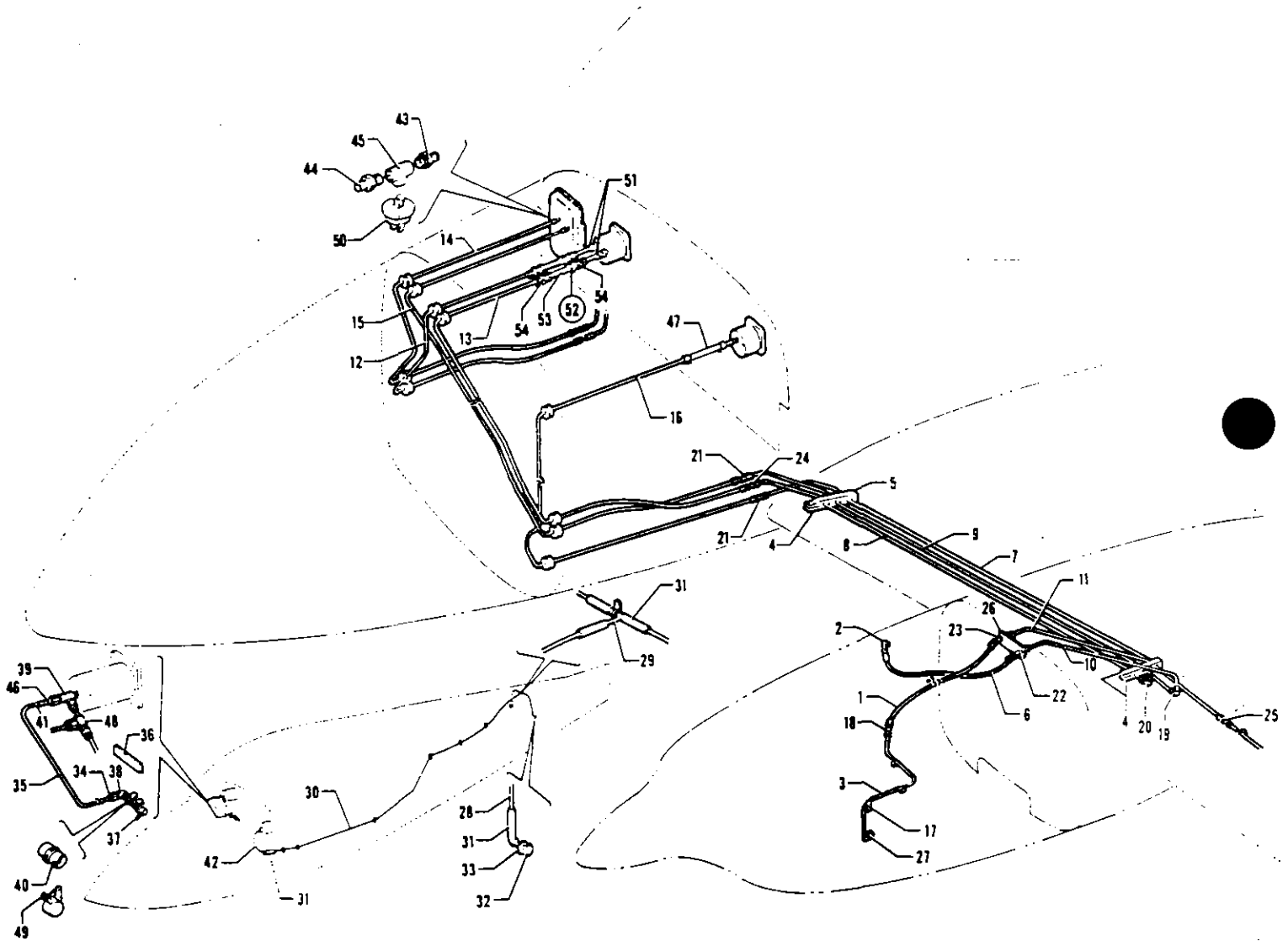

Figure 23. Airspeed, Static, Oil Pressure and Manifold Pressure Lines

SECTION II  
Fuselage Group



AIRSPEED, STATIC, OIL PRESSURE  
AND MANIFOLD PRESSURE LINES

Figure and Index Number	Part Number	Code	NOMENCLATURE	No. Req.	SERIAL NUMBERS AFFECTED
23-	23912		DRAWING - Miscellaneous Air and Fluid Lines Installation		
	20885	A	DRAWING - Static Vent Tubes Installation		
	25495	C	DRAWING - Static Vent Tubes Installation		
	25237	B	DRAWING - Alternate Static System Installation		
	26722	D	DRAWING - Alternate Static System Installation		
-1	39999-11		HOSE ASSEMBLY - Flexible	2	
-2	22114-00		ELBOW - 90° restricted	2	
-3	22362-03		LINE ASSEMBLY	2	30-2 to 30-1995 inclusive
	22362-05	YZ	LINE ASSEMBLY	2	30-1996 and up, 39-1 and up
-4	23684-00		BLOCK - Tube retaining	6	
-5	23684-02		BLOCK - Tube retaining	2	
-6	23745-08		HOSE ASSEMBLY - Flexible	2	
-7	23752-00		LINE ASSEMBLY	1	
-8	23884-02		TUBE ASSEMBLY - Manifold pressure, LH	1	
	23884-03		TUBE ASSEMBLY - Manifold pressure, RH	4	
-9	23887-02		LINE ASSEMBLY - Oil pressure, LH	1	
	23887-03		LINE ASSEMBLY - Oil pressure, RH	1	
-10	23888-00		LINE ASSEMBLY - Oil pressure	2	
-11	23889-00		LINE ASSEMBLY - Manifold pressure	2	
-12	23892-00	Y	LINE ASSEMBLY - Manifold pressure	1	30-2 to 30-1995 inclusive
	23892-03	YZ	LINE ASSEMBLY - Manifold pressure	1	30-1996 and up, 39-1 and up
-13	23893-00	Y	LINE ASSEMBLY - Manifold pressure	1	30-2 to 30-1995 inclusive
	23893-03	YZ	LINE ASSEMBLY - Manifold pressure	1	30-1996 and up, 39-1 and up
-14	23894-00		LINE ASSEMBLY - Oil pressure	1	
-15	23895-00		LINE ASSEMBLY - Oil pressure	1	
-16	23896-00	B	LINE ASSEMBLY - Airspeed (fitting on one end)	1	
	25712-00	B	LINE ASSEMBLY - Airspeed (fitting on both ends)	1	
	26787-00	D	LINE ASSEMBLY - Airspeed (fitting on one end)	1	
-17	80032-53		CLAMP - Offset	2	
-18	491 055		UNION - (AN815-4)	2	
-19	458 879		ELBOW - (AN821-3D)	2	
-20	458 880		ELBOW - (AN821-4D)	2	
-21	491 059		UNION - (AN832-3D)	3	
-22	458 937		ELBOW - (AN837-3)	2	
-23	458 938		ELBOW - (AN837-4)	2	
-24	458 910		ELBOW - (AN837-4D)	2	
-25	491 049		UNION - (AN815-3D)	1	
-26	24015-00		PLACARD - Firewall	2	
-27	460 885		CONNECTOR - (W/H 200 x 4)	2	

A - Used on PA-30 with serial numbers 30-2 to 30-852 inclusive, 30-854 to 30-901 inclusive.  
 B - Used on PA-30 with serial numbers 30-2 to 30-1716 inclusive, 30-1718 to 30-1744 inclusive.  
 C - Used on PA-30 with serial numbers 30-853, 30-902 and up, and PA-39 with serial numbers 39-1 and up.  
 D - Used on PA-30 with serial numbers 30-1717, 30-1745 and up, and PA-39 with serial numbers 39-1 and up.  
 Y - Used on PA-30 airplanes only.  
 Z - Used on PA-39 airplanes only.

When ordering, always specify Part Number, Description and Serial Number of Aircraft

AIRSPEED, STATIC, OIL PRESSURE  
AND MANIFOLD PRESSURE LINES



SECTION II  
Fuselage Group

Figure and Index Number	Part Number	Code	NOMENCLATURE	No. Req.	SERIAL NUMBERS AFFECTED
23-28	61323-09		HOSE - Static vent, left	1	
	61323-12		HOSE - Static vent, right	1	
-29	14493-00		TUBE ASSEMBLY - Static vent tee	1	
-30	20649-03	A	LINE ASSEMBLY - Static air	1	
	61323-13	C	LINE ASSEMBLY - Static air	1	
-31	83161-03		TUBE - Plastic	6	
-32	23558-00		FITTING - Static vent	2	
-33	484 744		RING - Retaining (#5115-18) (Static vent)	2	
-34	17881-04		LINE ASSEMBLY - Alternate static air	1	
-35	83161-41	B	HOSE - Alternate static air	1	
	16633-95	D	HOSE - Alternate static air	1	
-36	25220-00	B	PLACARD - Alternate static source control	1	
	26604-00	D	PLACARD - Alternate static source control	1	
-37	492 100		VALVE - Alternate static air (#CCA-7450)	1	
-38	458 893		ELBOW - (ANS22-3D) Alternate static	1	
-39	488 310		TEE - (ANS20-3D)	1	
-40	455 173		COUPLING - (AN910-1D)	1	
-41	454 833		CLAMP - (#6)	2	
-42	20649-05	C	LINE ASSEMBLY - Static air	1	
-43	476 649	E	NIPPLE - (ANS16-2D)	1	
-44	476 647	E	NIPPLE - (ANS16-3D)	1	
-45	488 474	E	TEE - (AN917-1D)	1	
-46	17881-04	B	LINE ASSEMBLY - Alternate static air	1	
	25705-00	D	LINE ASSEMBLY - Alternate static air	1	
-47	83161-27	D	HOSE - Airspeed indicator	1	
-48	488 525	D	TEE - Swivel (#3-SW-12)	1	
-49	25290-09		BRACKET ASSEMBLY - Alternate air valve	1	
-50	487 905	E	SWITCH - Pressure (#M-4006-4)	1	
-51	27023-00	YZ	LINE ASSEMBLY - Manifold pressure gauge	2	30-1996 and up, 39-1 and up
-52	43404-00	YZ	FILTER ASSEMBLY - Manifold pressure gauge	2	30-1996 and up, 39-1 and up
-53	754 817	YZ	FILTER	1	30-1996 and up, 39-1 and up
-54	43775-00	YZ	REDUCER	2	30-1996 and up, 39-1 and up

- A - Used on PA-30 with serial numbers 30-2 to 30-852 inclusive. 30-854 to 30-901 inclusive.
- B - Used on PA-30 with serial numbers 30-2 to 30-1716 inclusive. 30-1718 to 30-1744 inclusive.
- C - Used on PA-30 with serial numbers 30-853, 30-902 and up, and PA-39 with serial numbers 39-1 and up.
- D - Used on PA-30 with serial numbers 30-1717, 30-1745 and up, and PA-39 with serial numbers 39-1 and up.
- E - Used if Hour Meter is installed.
- Y - Used on PA-30 airplanes only.
- Z - Used on PA-39 airplanes only.

When ordering, always specify Part Number, Description and Serial Number of Aircraft



**1G17**

**INTENTIONALLY LEFT BLANK**

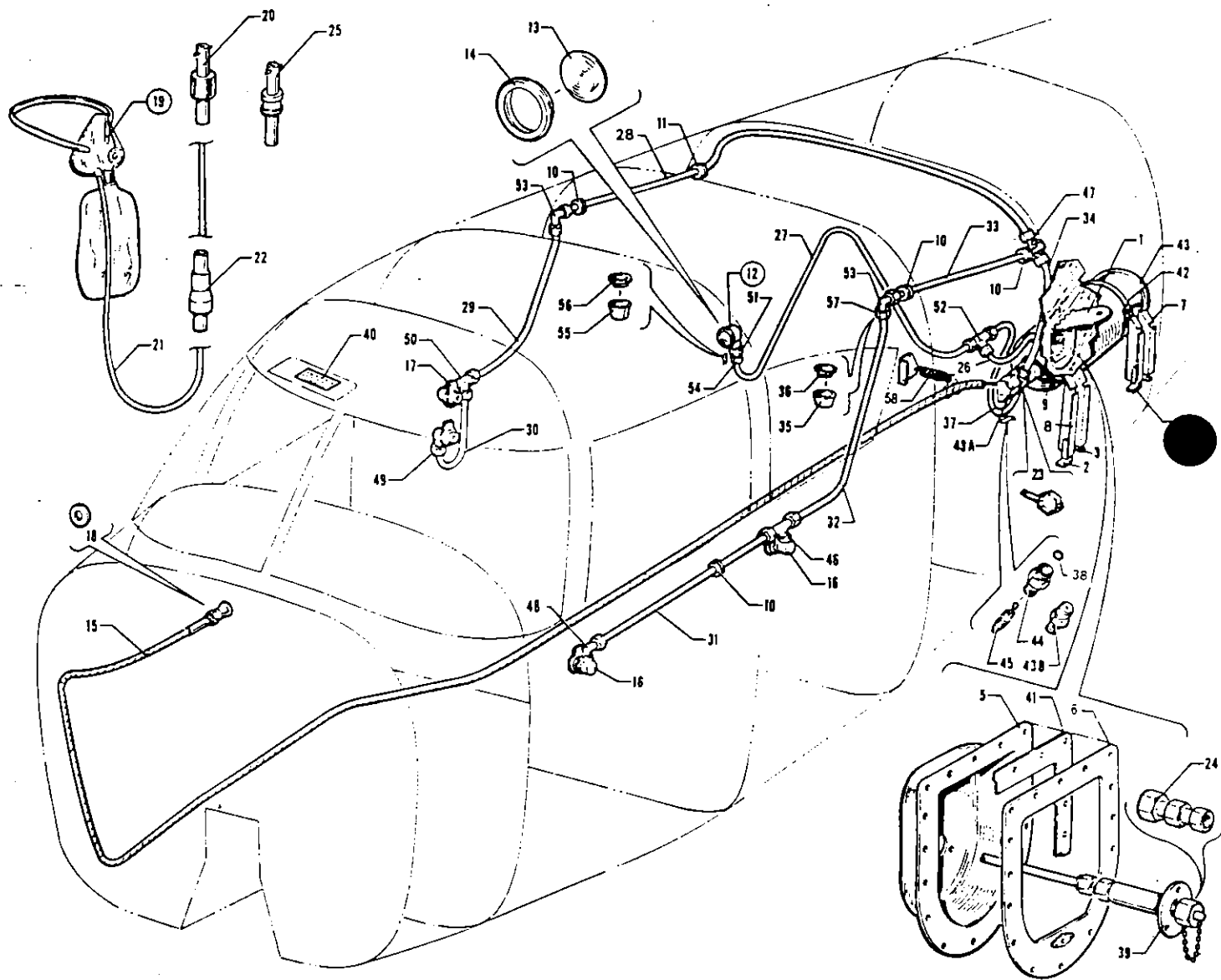

Figure 23A. Oxygen System Installation  
(PA-30 with Serial Nos. 30-2 to 30-852, 30-854 to 30-901 inclusive)

PIPER PARTS CATALOG

Figure and Index Number	Part Number	Code	NOMENCLATURE	No. Req.	SERIAL NUMBERS AFFECTED
23A	25342		DRAWING - Oxygen System Installation		
-1	19802-05		PLATE ASSEMBLY - Access	1	
-2	25392-02		CLIP - Mounting channel attachment	1	
-3	25392-03		CLIP - Mounting channel attachment	1	
-4	25392-04		CLIP - Mounting channel attachment	1	
-5	25393-00		PLATE - Recharge valve mounting	1	
-6	25394-00		PLATE ASSEMBLY - Recharge valve mounting	1	
-7	25395-00		CHANNEL ASSEMBLY - Cylinder mounting, rear	1	
-8	25396-00		CHANNEL ASSEMBLY - Cylinder mounting, front	1	
-9	25397-00		CABLE ASSEMBLY - Cylinder restraining	1	
-10	434 138		GROMMET - (AN931-10-14)	4	
-11	434 132		GROMMET - (AN931-11-16)	1	
-12	751 913		GAUGE ASSEMBLY - Oxygen (includes mounting bracket)	1	
-13	752 355		* LENS - Gauge assembly	1	
-14	753 433		* BEZEL - Gauge assembly	1	
-15	753 938		CABLE ASSEMBLY - Push-pull control	1	
-16	752 583		OUTLET ASSEMBLY - Oxygen	4	
-17	757 213		PLATE - Outlet assembly, instruction	4	
-18	754 547		DECAL - Control cable	1	
-19	474 055	B	MASK ASSEMBLY - Oxygen, nasal type, 2.0 LPM (crew)	AR	
	474 085		MASK ASSEMBLY - Oxygen, sky mask, 2.0 LPM (crew)	AR	
	474 087		MASK ASSEMBLY - Oxygen, sky mask, 1.5 LPM (passenger)	AR	
	753 743	C	MASK ASSEMBLY - Oxygen, oronasal with microphone, 2.0 LPM (pilot)	1	
	474 111	C	MASK ASSEMBLY - Oxygen, duo-seal mask with microphone, 2.0 LPM (crew)	AR	
	479 445	D	MASK ASSEMBLY - Oxygen, duo-seal mask with microphone and remote switch, 2.0 LPM (crew)	AR	
-20	753 974		* COUPLING - Oxygen plug-in, 2.0 LPM	AR	
	753 975		* COUPLING - Oxygen plug-in, 1.5 LPM	AR	
-21	753 074		* TUBING - Plastic, oxygen mask (5' length)	1	
	756 319		* TUBING - Rubber, oxygen mask (4 1/2' length)	1	
-22	752 122		* FLOW INDICATOR ASSEMBLY	1	
-23	753 437		BRACKET ASSEMBLY - Control cable	1	
-24	757 810		COUPLING - Oxygen filler	1	
-25	753 941		COUPLING - Oxygen plug-in, therapeutic, 7.5 LPM	AR	
-26	31978-11		LINE - Oxygen, high pressure	1	
-27	31978-12		LINE - Oxygen, high pressure	1	
-28	31978-13		LINE - Oxygen, low pressure	1	
-29	31978-14		LINE - Oxygen, low pressure	1	
-30	31978-15		LINE - Oxygen, low pressure	1	
-31	31978-16		LINE - Oxygen, low pressure	1	
-32	31978-17		LINE - Oxygen, low pressure	1	
-33	31978-18		LINE - Oxygen, low pressure	1	
-34	31978-19		LINE - Oxygen, low pressure	1	

A - Used on PA-30 with serial numbers 30-2 to 30-852 inclusive, 30-854 to 30-901 inclusive.  
 B - No longer available. Order mask assembly part number 474 111 or part number 479 445 or part number 753 743.  
 C - Used if boom mike is installed.  
 D - Used if boom mike is not installed.

When ordering, always specify Part Number, Description and Serial Number of Aircraft

**PIPER PARTS CATALOG**

Figure and Index Number	Part Number	Code	NOMENCLATURE	No. Req.	SERIAL NUMBERS AFFECTED
23A-35	751 813		FERRULE - Flareless fitting, front (1/4")	AR	
-36	751 814		FERRULE - Flareless fitting, back (1/4")	AR	
-37	756 300		TUBE ASSEMBLY - High pressure	1	
-38	755 946		* "O" RING - Tube assembly	1	
-39	756 504		VALVE ASSEMBLY - Recharge	1	
-40	753 942		CHART - Instrument and duration	1	
-41	25603-00		PLATE - Reinforcement	1	
-42	753 435		BRACKET ASSEMBLY - Cylinder mounting	2	
-43	753 943		CYLINDER AND REGULATOR ASSEMBLY	1	
-43a	756 038		* REGULATOR ASSEMBLY - Oxygen	1	
-43b	756 507		* * RELIEF VALVE - Regulator assembly	1	
-44	756 505		* * VALVE ASSEMBLY - Charging	1	
-45	753 947		* * * CORE - Valve assembly	1	
-46	756 301	B	TEE - Low pressure (33529-805)	1	
-47	756 302	B	TEE - Low pressure (33529-204)	1	
-48	754 761	B	ELBOW - (33529-106)	1	
-49	753 944	B	CONNECTOR - (33529-009)	1	
-50	756 303	B	TEE - (33529-905)	1	
-51	753 945	B	CONNECTOR - (33525-702)	2	
-52	756 304	B	TEE - High pressure (33525-902)	1	
-53	754 762	B	ELBOW - (33529-704)	2	
-54	752 504		NUT - Flareless fitting (1/8")	AR	
-55	751 811		FERRULE - Flareless fitting, front (1/8")	AR	
-56	751 812		FERRULE - Flareless fitting, back (1/8")	AR	
-57	752 505		NUT - Flareless fitting (1/4")	AR	
-58	83302-24		SPRING - Control cable	1	

A - Used on PA-30 with serial numbers 30-2 to 30-852 inclusive, 30-854 to 30-901 inclusive.  
B - Nuts and ferrules supplied with fitting.

When ordering, always specify Part Number, Description and Serial Number of Aircraft

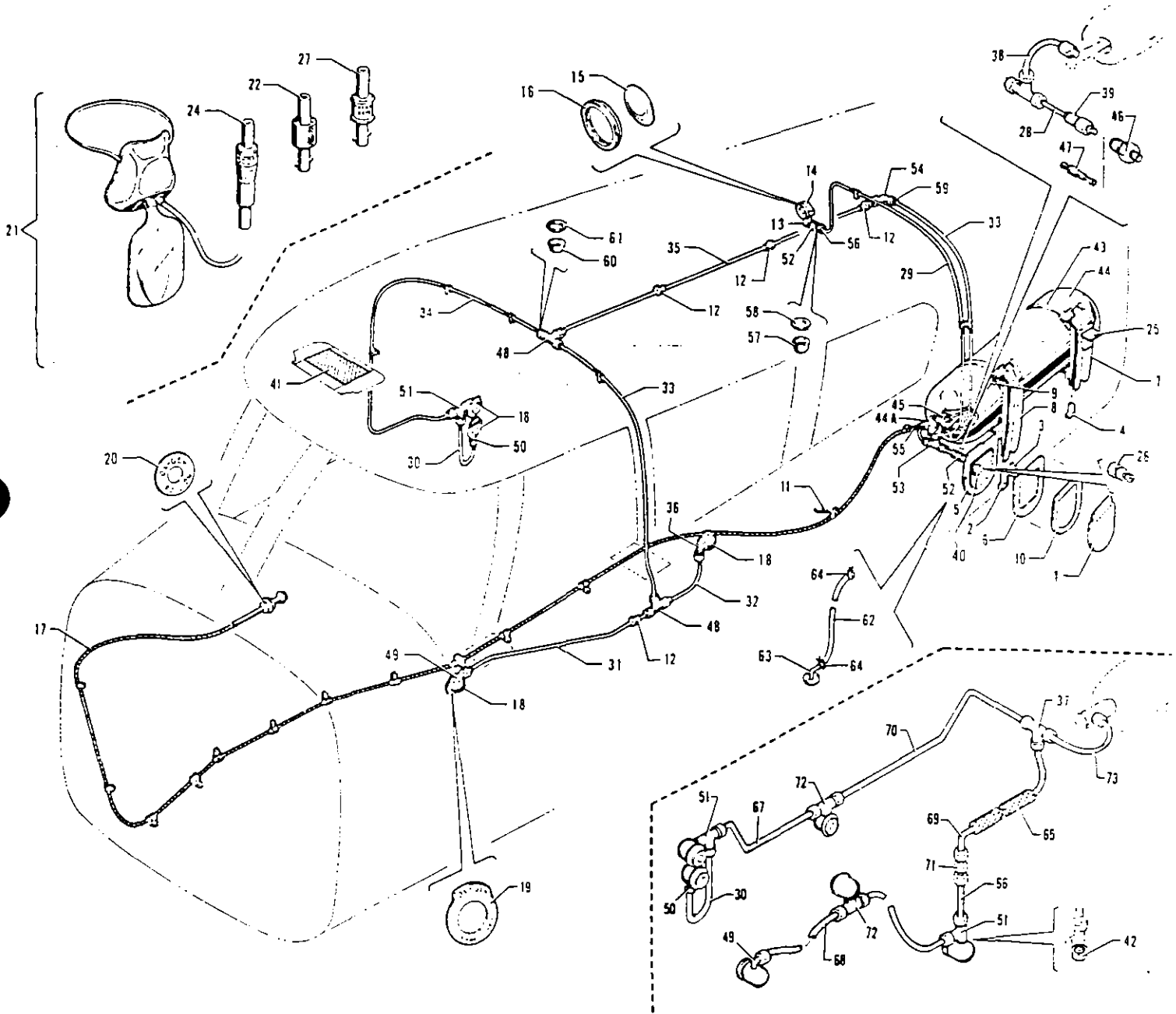

Figure 23B. Oxygen System Installation  
(PA-30 with Serial Nos. 30-853, 30-902 to 30-1716, 30-1718 to 30-1744 inclusive)

PIPER PARTS CATALOG

Figure and Index Number	Part Number	Code	NOMENCLATURE	No. Req.	SERIAL NUMBERS AFFECTED
23B-	25542	B	DRAWING - Oxygen System Installation		
	25724	C	DRAWING - Oxygen System Installation		
-1	19802-05		PLATE ASSEMBLY - Access	1	
-2	25392-02		CLIP - Mounting channel attachment	1	
-3	25392-03		CLIP - Mounting channel attachment	1	
-4	25392-04		CLIP - Mounting channel attachment	1	
-5	25393-00		PLATE - Recharge valve mounting	1	
	25697-00		PLATE - Recharge valve mounting (with drain take-off)	1	
-6	25394-00		PLATE ASSEMBLY - Valve mounting	1	
-7	25395-00		CHANNEL ASSEMBLY - Cylinder mounting, rear	1	
-8	25396-00		CHANNEL ASSEMBLY - Cylinder mounting, front	1	
-9	25397-00		CABLE ASSEMBLY - Cylinder restraining	1	
-10	25603-00		PLATE - Reinforcement, valve mounting	1	
-11	83302-24		SPRING - Control cable	1	
-12	453 732		BUSHING - Snap ( SB-375-4)	4	
-13	754 769		ELBOW - Pressure gauge	1	
-14	751 913		GAUGE ASSEMBLY - Oxygen (includes mounting bracket)	1	30-853, 30-902 to 30-1656
	751 896	D	GAUGE ASSEMBLY - Oxygen (includes mounting bracket)	1	
-15	752 355		* LENS - Gauge assembly	1	
-16	753 433		* BEZEL - Gauge assembly	1	
-17	753 938		CABLE ASSEMBLY - Push-pull control	1	
-18	752 583		OUTLET ASSEMBLY - Oxygen	6	
-19	757 213		PLATE - Outlet assembly, instruction	6	
-20	754 547		DECAL - Control cable	1	
-21	474 055	E	MASK ASSEMBLY - Oxygen, nasal type, 2.0 LPM (crew)	AR	
	474 085		MASK ASSEMBLY - Oxygen, sky mask, 2.0 LPM (crew)	AR	
	474 087		MASK ASSEMBLY - Oxygen, sky mask, 1.5 LPM (passenger)	AR	
	753 743	F	MASK ASSEMBLY - Oxygen, oronasal with microphone, 2.0 LPM (pilot)	1	
	474 111	F	MASK ASSEMBLY - Oxygen, duo-seal mask with microphone, 2.0 LPM (crew)	AR	
	479 445	G	MASK ASSEMBLY - Oxygen, duo-seal mask with microphone and remote switch, 2.0 LPM (crew)	AR	
-22	753 974		* COUPLING - Oxygen plug-in, 2.0 LPM	AR	
	753 975		* COUPLING - Oxygen plug-in, 1.5 LPM	AR	
-23	753 074		* TUBING - Plastic, oxygen mask (5' length)	1	
	756 319		* TUBING - Rubber, oxygen mask (4 1/2' length)	1	
-24	752 122		* FLOW - Indicator assembly	1	
-25	25951-00		BRACKET - Reinforcement	2	
-26	757 810		COUPLING - Oxygen filler	1	
-27	753 941		COUPLING - Oxygen plug-in, therapeutic, 7.5 LPM	AR	
-28	31978-11		LINE - Oxygen, high pressure	1	

- A - Used on PA-30 with serial numbers 30-853, 30-902 to 30-1716 inclusive, 30-1718 to 30-1744 inclusive.
- B - Used when oxygen lines are installed above the headlining.
- C - Used when oxygen lines are installed back of side panels.
- D - Used on PA-30 with serial numbers 30-1657 to 30-1716 inclusive, 30-1718 to 30-1744 inclusive.
- E - No longer available. Order mask assembly part number 474 111 or part number 479 445 or part number 753 743.
- F - Used if boom mike is installed.
- G - Used if boom mike is not installed.

When ordering, always specify Part Number, Description and Serial Number of Aircraft

PIPER PARTS CATALOG

Figure and Index Number	Part Number	Code	NOMENCLATURE	No. Req.	SERIAL NUMBERS AFFECTED
23B-29	25568-08		LINE - Oxygen, high pressure	1	
-30	31978-15		LINE - Oxygen, low pressure	1	
-31	25568-02	B	LINE - Oxygen, low pressure	1	
-32	25568-03	B	LINE - Oxygen, low pressure	1	
-33	25568-04	B	LINE - Oxygen, low pressure	2	
-34	25568-05	B	LINE - Oxygen, low pressure	1	
-35	25568-06	B	LINE - Oxygen, low pressure	1	
-36	754 761	BD	ELBOW - (33529-106)	1	
-37	756 302	CD	TEE - Low pressure (33529-204)	1	
-38	756 300		TUBE ASSEMBLY - High pressure	1	
-39	755 946		* "O" RING - Tube assembly	1	
-40	756 504		VALVE ASSEMBLY - Recharge	1	
-41	753 942		CHART - Instrument and duration	1	
-42	757 826		CAP - Low pressure (33527-901)	2	
-43	758 110		BRACKET ASSEMBLY - Cylinder mounting	2	
-44	753 943		CYLINDER AND REGULATOR ASSEMBLY	1	
-44a	756 038		* REGULATOR ASSEMBLY - Oxygen	1	
-45	756 507		* * RELIEF VALVE - Regulator assembly	1	
-46	756 505		* * VALVE ASSEMBLY - Charging	1	
-47	753 947		* * * CORE - Valve assembly	1	
-48	756 302	BD	TEE - Low pressure (33529-204)	2	
-49	754 761	D	ELBOW - (33529-106)	1	
-50	753 944	D	CONNECTOR - (33529-009)	4	
-51	756 303	D	TEE - (33529-905)	2	
-52	753 945	D	CONNECTOR - (33525-702)	2	
-53	756 304	D	TEE - High pressure (33525-902)	1	
-54	754 762	D	ELBOW - (33529-704)	1	
-55	753 437		BRACKET ASSEMBLY - Control cable	1	
-56	752 504		NUT - Flareless fitting (1/8")	AR	
-57	751 811		FERRULE - Flareless fitting, front (1/8")	AR	
-58	751 812		FERRULE - Flareless fitting, back (1/8")	AR	
-59	752 505		NUT - Flareless fitting (1/4")	AR	
-60	751 813		FERRULE - Flareless fitting, front (1/4")	AR	
-61	751 814		FERRULE - Flareless fitting, back (1/4")	AR	
-62	22369-31		TUBE - Drain	1	
-63	24623-00		TUBE ASSEMBLY - Drain	1	
-64	454 833		CLAMP - (SAE #6)	2	
-65	16633-67	C	HOSE	1	
-66	25568-14	C	LINE - Oxygen, low pressure	1	
-67	25568-10	C	LINE - Oxygen, high pressure	2	
-68	25568-11	C	LINE - Oxygen, low pressure	1	
-69	25568-12	C	LINE - Oxygen, low pressure	1	
-70	25568-13	C	LINE - Oxygen, low pressure	1	
-71	753 081	CD	UNION	1	
-72	756 301	CD	TEE - (33529-805)	1	
-73	31978-15	C	LINE - Oxygen, low pressure	1	

- A - Used on PA-30 with serial numbers 30-853, 30-902 to 30-1716 inclusive, 30-1718 to 30-1744 inclusive.
- B - Used when oxygen lines are installed above the headlining.
- C - Used when oxygen lines are installed back of side panels.
- D - Nuts and ferrules supplied with fitting.

When ordering, always specify Part Number, Description and Serial Number of Aircraft

**1G24**  
**INTENTIONALLY LEFT BLANK**



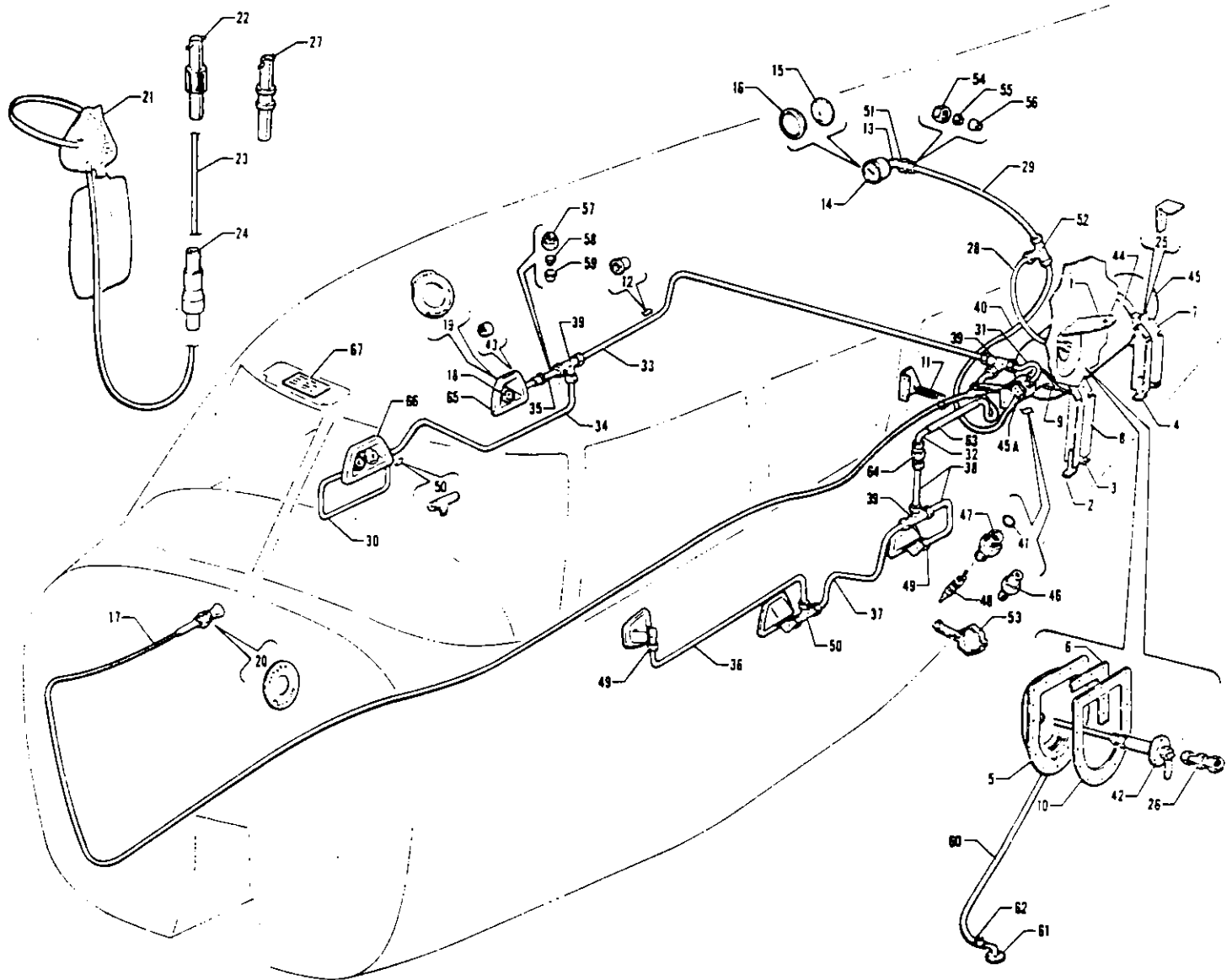

Figure 23C. Oxygen System Installation  
 (PA-30 with Serial Nos. 30-1717, 30-1745 and up)  
 (PA-39 with Serial Nos. 39-1 and up)

PIPER PARTS CATALOG

Figure and Index Number	Part Number	Code	NOMENCLATURE	No. Req.	SERIAL NUMBERS AFFECTED
23C-	26682		DRAWING - Oxygen System Installation		
-1	19802-05		PLATE ASSEMBLY - Access	1	
-2	25392-02		CLIP - Mounting channel attachment	1	
-3	25392-03		CLIP - Mounting channel attachment	1	
-4	25392-04		CLIP - Mounting channel attachment	1	
-5	25697-00		PLATE - Recharge valve mounting (with drain take-off)	1	
-6	25394-00		PLATE ASSEMBLY - Valve mounting	1	
-7	25395-00		CHANNEL ASSEMBLY - Cylinder mounting, rear	1	
-8	25396-00		CHANNEL ASSEMBLY - Cylinder mounting, front	1	
-9	25397-00		CABLE ASSEMBLY - Cylinder restraining	1	
-10	25603-00		PLATE - Reinforcement, valve mounting	1	
-11	83302-24		SPRING - Control cable	1	
-12	453 732		BUSHING - Snap ( SB-375-4)	12	
-13	754 769		ELBOW - Pressure gauge	1	
-14	751 896		GAUGE ASSEMBLY - Oxygen (includes mounting bracket)	1	
-15	752 355		* LENS - Gauge assembly	1	
-16	753 433		* BEZEL - Gauge assembly	1	
-17	753 938		CABLE ASSEMBLY - Push-pull control	1	
-18	752 583		OUTLET ASSEMBLY - Oxygen	6	
-19	757 213		PLATE - Outlet assembly, instruction	6	
-20	754 547		DECAL - Control cable	1	
-21	474 055	C	MASK ASSEMBLY - Oxygen, nasal type, 2.0 LPM (crew)	AR	
	474 085		MASK ASSEMBLY - Oxygen, sky mask, 2.0 LPM (crew)	AR	
	474 087		MASK ASSEMBLY - Oxygen, sky mask, 1.5 LPM (passenger)	AR	
	753 743	D	MASK ASSEMBLY - Oxygen, oronasal with microphone, 2.0 LPM (pilot)	1	
	474 111	D	MASK ASSEMBLY - Oxygen, duo-seal mask with microphone, 2.0 LPM (crew)	AR	
	479 445	E	MASK ASSEMBLY - Oxygen, duo-seal mask with microphone and remote switch, 2.0 LPM (crew)	AR	
-22	753 974		* COUPLING - Oxygen plug-in, 2.0 LPM	AR	
	753 975		* COUPLING - Oxygen plug-in, 1.5 LPM	AR	
-23	753 074		* TUBING - Plastic, oxygen mask (5' length)	1	
	756 319		* TUBING - Rubber, oxygen mask (4 1/2' length)	1	
-24	752 122		* FLOW - Indicator assembly	1	
-25	25951-00		BRACKET - Reinforcement	2	
-26	757 810		COUPLING - Oxygen filler	1	
-27	753 941		COUPLING - Oxygen plug-in, therapeutic, 7.5 LPM	AR	
-28	31978-11		LINE - Oxygen, high pressure	1	
-29	25568-08		LINE - Oxygen, high pressure	1	
-30	25568-18		LINE - Oxygen, low pressure	1	
-31	31978-15		LINE - Oxygen, low pressure	1	
-32	25568-12		LINE - Oxygen, low pressure	1	
			A - Used on PA-30 with serial numbers 30-1717, 30-1745 and up, and PA-39 with serial numbers 39-1 and up.		
			B - Nuts and ferrules supplied with fitting.		
			C - No longer available. Order mask assembly part number 474 111 or part number 479 445 or part number 753 743.		
			D - Used if boom mike is installed.		
			E - Used if boom mike is not installed.		

When ordering, always specify Part Number, Description and Serial Number of Aircraft

PIPER PARTS CATALOG

Figure and Index Number	Part Number	Code	NOMENCLATURE	No. Req.	SERIAL NUMBERS AFFECTED
23C-33	25568-15		LINE - Oxygen, low pressure	1	
-34	25568-16		LINE - Oxygen, low pressure	1	
-35	25568-17		LINE - Oxygen, low pressure	1	
-36	25568-21		LINE - Oxygen, low pressure	1	
-37	25568-19		LINE - Oxygen, low pressure	1	
-38	25568-20		LINE - Oxygen, low pressure	2	
-39	756 302	B	TEE - Low pressure (33529-204)	3	
-40	756 300		TUBE ASSEMBLY - High pressure	1	
-41	755 946		* "O" RING - Tube assembly	1	
-42	756 504		VALVE ASSEMBLY - Recharge	1	
-43	757 826		CAP - Low pressure (33527-901)	2	
-44	758 110		BRACKET ASSEMBLY - Cylinder mounting	2	
-45	753 943		CYLINDER AND REGULATOR ASSEMBLY	1	
-45a	756 038		* REGULATOR ASSEMBLY - Oxygen	1	
-46	756 507		* * RELIEF VALVE - Regulator assembly	1	
-47	756 505		* * VALVE ASSEMBLY - Charging	1	
-48	753 947		* * * CORE - Valve assembly	1	
-49	753 944	B	CONNECTOR - (33529-009)	4	
-50	756 303	B	TEE - (33529-905)	2	
-51	753 945	B	CONNECTOR - (33525-702)	2	
-52	756 304	B	TEE - High pressure (33525-902)	1	
-53	753 437		BRACKET ASSEMBLY - Control cable	1	
-54	752 504		NUT - Flareless fitting (1/8")	AR	
-55	751 811		FERRULE - Flareless fitting, front (1/8")	AR	
-56	751 812		FERRULE - Flareless fitting, back (1/8")	AR	
-57	752 505		NUT - Flareless fitting (1/4")	AR	
-58	751 813		FERRULE - Flareless fitting, front (1/4")	AR	
-59	751 814		FERRULE - Flareless fitting, back (1/4")	AR	
-60	22369-31		TUBE - Drain	1	
-61	24623-00		TUBE ASSEMBLY - Drain	1	
-62	454 833		CLAMP - (SAE #6)	2	
-63	16633-67		HOSE	1	
-64	753 081	B	UNION	1	
-65	26524-02		PLATE - Oxygen outlet trim, beige	4	
	26524-03		PLATE - Oxygen outlet trim, black	4	
	26524-04		PLATE - Oxygen outlet trim, white	4	
-66	26535-02		PLATE - Oxygen outlet trim, beige	1	
	26535-03		PLATE - Oxygen outlet trim, black	1	
	26535-04		PLATE - Oxygen outlet trim, white	1	
-67	753 942		CHART - Instrument and duration	1	

A - Used on PA-30 with serial numbers 30-1717, 30-1745 and up, and PA-39 with serial numbers 39-1 and up.  
B - Nuts and ferrules supplied with fitting.

When ordering, always specify Part Number, Description and Serial Number of Aircraft

**1H4**  
**INTENTIONALLY LEFT BLANK**

# PIPER PARTS CATALOG

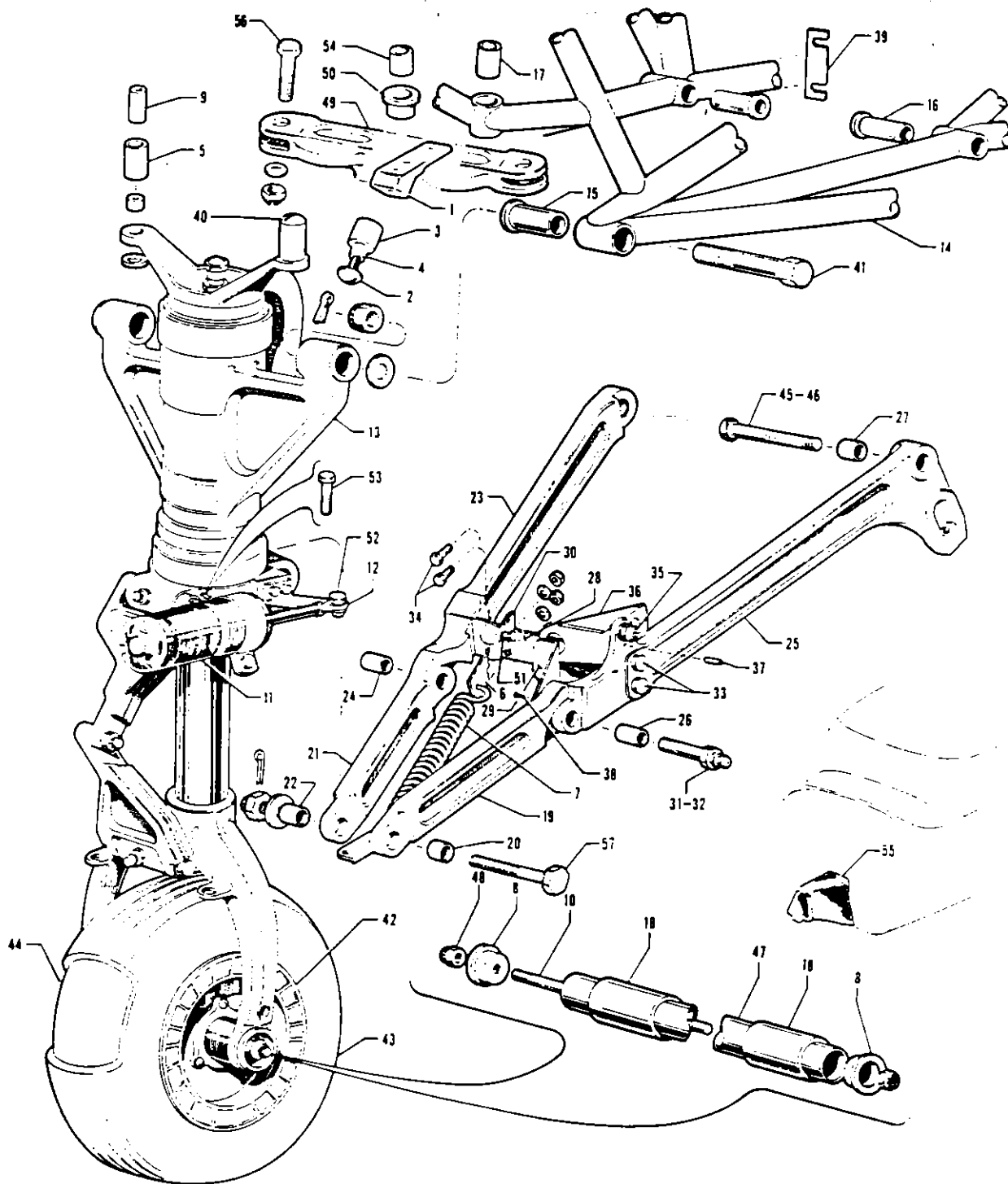

Figure 24. Nose Gear Installation

REVISED: MAY 1980

1H5

PA-30  
PA-39

Island Enterprises

PIPER PARTS CATALOG

Figure and Index Number	Part Number	Code	NOMENCLATURE	No. Req.	SERIAL NUMBERS AFFECTED
24-	23679	Y	DRAWING - Nose Landing Gear Installation		30-2 to 30-845 inclusive
	25293	YZ	DRAWING - Nose Landing Gear Installation		30-846 and up, 39-1 and up
-1	21725-00		ALIGNER ASSEMBLY - Nose gear	1	
-2	411 349		* SCREW - Nylon insert	1	
-3	14976-15		* BUSHING	1	
-4	14976-16		* BUSHING	1	
-5	14976-13		BUSHING - (3/4 O.D. x 1-1/32 L)	2	
	14976-21		BUSHING - (11/16 O.D. x 1-1/32 L)	2	
	14976-23		BUSHING - (5/8 O.D. x 1-1/32 L)	2	
	14976-102		BUSHING - (13/16 O.D. x 1-1/32 L)	2	
	14175-113		BUSHING - (1.00 O.D. x 1-1/32 L)	2	
-6	81262-92		LINK - Nose gear spring attachment, right	1	
	81262-92	DG	LINK - Nose gear spring attachment, left	2	
-7	13098-00		SPRING - Nose gear downlock, right	1	
	13098-00	DG	SPRING - Nose gear downlock, left	1	
-8	20825-00		PLUG - Wheel end	2	
-9	14976-12		BUSHING - (.438 O.D. x 1-1/16 L)	2	
-10	20854-00		ROD - Wheel axle tie	1	
-11	21701-03	BY	DAMPENER ASSEMBLY - Nose wheel shimmy	1	30-2 to 30-1198 inclusive
	21701-05	YZ	DAMPENER ASSEMBLY - Nose wheel shimmy	1	30-1199 and up, 39-1 and up
-12	11601-03	BY	* BOLT - Eye, shimmy dampener	1	30-2 to 30-1198 inclusive
	452 357	YZ	* BEARING ASSEMBLY - Shimmy dampener	1	30-1199 and up, 39-1 and up
-13	22810-00	ACY	STRUT ASSEMBLY - Nose gear	1	30-2 to 30-1198 inclusive
	22810-03	AY	STRUT ASSEMBLY - Nose gear	1	30-1199 to 30-1716 inclusive 30-1718 to 30-1744 inclusive
	22810-04	AD	STRUT ASSEMBLY - Nose gear	1	
-14	23658-00	Y	MOUNT ASSEMBLY - Nose gear	1	30-2 to 30-852 inclusive, 30-854 to 30-901 inclusive
	23658-22	YZ	MOUNT ASSEMBLY - Nose gear	1	30-853, 30-902 and up, 39-1 and up
-15	17164-04		* BUSHING - Nose gear mounting	2	
-16	20803-02		* BUSHING - Nose gear mounting	2	
-17	80012-77		* BUSHING - Nose gear mounting	1	
-18	86062-88	E	BUSHING - Nose wheel spacer	2	
	31786-03	F	BUSHING - Nose wheel spacer	2	

- A - See Figure 26 for component parts.
- B - Order part for PA-30 with serial numbers 30-1199 and up if shimmy dampener incorporates a self-aligning end bearing.
- C - Order nose gear strut 22810-04 if shimmy dampener incorporates a self-aligning end bearing.
- D - Used on PA-30 with serial numbers 30-1717, 30-1745 and up, and PA-39 with serial numbers 39-1 and up.
- E - Used with Model No. 38501 nose wheel assembly.
- F - Used with Model No. 40-76B nose wheel assembly.
- G - Used on PA-30 with serial numbers 30-2 to 30-1716, 30-1718 to 30-1744 inclusive if Landing Gear Emergency Extension Security Installation Kit 760 627 has been installed per Service Spares Letter SP-325 or Nose Gear Down Lock Spring Installation Kit 761 082 has been installed per Service Letter 782.
- Y - Used on PA-30 airplanes only.
- Z - Used on PA-39 airplanes only.

When ordering, always specify Part Number, Description and Serial Number of Aircraft



Figure and Index Number	Part Number	Code	NOMENCLATURE	No. Req.	SERIAL NUMBERS AFFECTED
24-19	20814-00		LINK ASSEMBLY - Nose gear left front drag	1	
-20	14843-18		BUSHING	2	
-21	20815-00		LINK ASSEMBLY - Nose gear right front drag	1	
-22	14843-18		BUSHING	2	
-23	20819-00		LINK ASSEMBLY - Nose gear right rear drag	1	
-24	14843-18		BUSHING	2	
-25	23109-00		LINK ASSEMBLY - Nose gear left rear drag	1	
-26	14843-18		BUSHING	1	
-27	14843-19		BUSHING	1	
-28	20821-02	CY	BRACE - Nose gear drag link cross	1	30-2 to 30-1716 inclusive, 30-1718 to 30-1744 inclusive
	26807-00	A	BRACE - Nose gear drag link cross	1	
-29	21698-00		PLATE - Nose gear switch actuator	1	
-30	21830-00		LUG - Nose gear spring rear attachment, right	1	
	21830-01	AB	LUG - Nose gear spring rear attachment, left	1	
-31	22066-00		BOLT - Special, left	1	
	407 587		WASHER - (AN960-616L) Left	1	
	404 103		NUT - (AN310-6) Left	1	
	424 059		PIN - Cotter (AN380-3-3) Left	1	
-32	22066-00		BOLT - Special, right	1	
	407 567		WASHER - (AN960-616) Right	1	
	404 103		NUT - (AN310-6) Right	1	
	424 059		PIN - Cotter (AN380-3-3) Right	1	
-33	400 009		BOLT - (AN4-14A)	4	
	407 565		WASHER - (AN960-416)	4	
	404 888		NUT - (MS20366-428C)	4	
-34	401 266	Y	BOLT - (AN3-5A)	2	30-2 to 30-1716 inclusive, 30-1718 to 30-1744 inclusive
	401 266	A	BOLT - (AN3-5A)	3	
	407 584	Y	WASHER - (AN960-10L)	2	30-2 to 30-1716 inclusive, 30-1718 to 30-1744 inclusive
	407 584	A	WASHER - (AN960-10L)	3	
	404 887	Y	NUT - (MS20366-1032C)	2	30-2 to 30-1716 inclusive, 30-1718 to 30-1744 inclusive
	404 887	A	NUT - (MS20366-1032C)	3	
-35	400 004		BOLT - (AN4-7A)	1	
	407 565		WASHER - (AN960-416)	1	
	404 888		NUT - (MS20366-428C)	1	
-36	21868-00	Y	BRACKET - Nose gear switch mounting	1	30-2 to 30-694 inclusive
	24916-00	YZ	BRACKET - Nose gear switch mounting	1	30-695 and up, 39-1 and up
-37	480 700		PIN - Roll (59-022-094-0375)	1	
-38	419 600		SCREW - Drive (AN535-2-4)	1	

A - Used on PA-30 with serial numbers 30-1717, 30-1745 and up, and PA-39 with serial numbers 39-1 and up.  
 B - Used on PA-30 with serial numbers 30-2 to 30-1716, 30-1718 to 30-1744 inclusive if Landing Gear Emergency Extension Security Installation Kit 760 627 has been installed per Service Spares Letter SP-325 or Nose Gear Down Lock Spring Installation Kit 761 082 has been installed per Service Letter 782.  
 C - Order part number 26807-00 if Landing Gear Emergency Extension Security Installation Kit 760 627 has been installed per Service Spares Letter SP-325.  
 Y - Used on PA-30 airplanes only.  
 Z - Used on PA-39 airplanes only.

When ordering, always specify Part Number, Description and Serial Number of Aircraft

PIPER PARTS CATALOG

Figure and Index Number	Part Number	Code	NOMENCLATURE	No. Req.	SERIAL NUMBERS AFFECTED
24-39	21820-02		SHIM - (.016)	AR	
	21820-03		SHIM - (.020)	AR	
	21820-04		SHIM - (.032)	AR	
-40	400 748		BOLT - (AN25-36)	2	
	407 566		WASHER - (AN960-516)	2	
	404 394		NUT - (AN320-5)	2	
	424 051		PIN - Cotter (AN380-2-2)	2	
-41	402 530		BOLT - (AN178-40)	2	
	407 569		WASHER - (AN960-816)	4	
	404 105		NUT - (AN310-8)	2	
	424 059		PIN - (AN380-3-3)	2	
-42	451 755	CD	WHEEL ASSEMBLY - Nose (38501)	1	
	451 784	C	WHEEL ASSEMBLY - Nose (40-76B)	1	39-149, 39-152 and up
-43	761 972		TIRE - (6.00 x 6 - 6 ply) B. F. Goodrich	1	
	761 995		TIRE - (6.00 x 6 - 6 ply) McCreary Airhawk	1	
	762 033		TIRE - (6.00 x 6 - 6 ply) Goodyear Flight Custom II	1	
-44	451 735		TUBE - (6.00 x 6)	1	
-45	400 223		BOLT - (AN6-30) Left	1	
	407 567		WASHER - (AN960-616) Left	3	
	404 103		NUT - (AN310-6) Left	1	
	424 059		PIN - Cotter (AN380-3-3) Left	1	
-46	400 218		BOLT - (AN6-25) Right	1	
	407 567		WASHER - (AN960-616) Right	2	
	404 103		NUT - (AN310-6) Right	1	
	424 059		PIN - Cotter (AN380-3-3) Right	1	
-47	86062-86		AXLE - Landing gear wheel	1	
-48	752 482		NUT - Axle (MS20364-624C)	2	
-49	21708-00		BELLCRANK ASSEMBLY - Nose wheel steering	1	
-50	21831-02		* BEARING	1	
-51	80012-06	Y	BUSHING - Right	1	
	80012-06	B	BUSHING - Left	1	
-52	400 105	AY	BOLT - (AN4-10)	1	30-2 to 30-1198 inclusive
	400 441	YZ	BOLT - (AN3-7A)	1	30-1199 and up, 39-1 and up
	407 565	AY	WASHER - (AN960-416)	3	30-2 to 30-1198 inclusive
	407 584	YZ	WASHER - (AN960-10L)	1	30-1199 and up, 39-1 and up
	404 101	AY	NUT - (AN310-4)	1	30-2 to 30-1198 inclusive
	404 887	YZ	NUT - (MS20365-1032C)	1	30-1199 and up, 39-1 and up
	424 051	Y	PIN - Cotter (AN380-2-2)	1	30-2 to 30-1198 inclusive

- A - Order part for serial numbers 30-1199 and up if shimmy dampener incorporates a self-aligning end bearing.
- B - Used on PA-30 with serial numbers 30-1717, 30-1745 and up, and PA-39 with serial numbers 39-1 and up. Also used on PA-30 with serial numbers 30-2 to 30-1716, 30-1718 to 30-1744 incl. if Landing Gear Emergency Extension Security Installation Kit 760 627 has been installed per Service Spares Letter SP-325 or Nose Gear Down Lock Spring Installation Kit 761 082 has been installed per Service Letter 782.
- C - See Figure 27A for component parts.
- D - Used on PA-30 with serial numbers 30-2 to 30-2000 inclusive and PA-39 with serial numbers 39-1 to 39-148 inclusive, 39-150 and 39-151. Part is no longer available. Order Wheel Assembly Part No. 451 784 and two spacer bushings Part No. 31786-03 when replacing Model No. 38501 wheel. Order Part No. 451 784 wheel only, if Model No. 40-76B has previously been installed.
- Y - Used on PA-30 airplanes only.
- Z - Used on PA-39 airplanes only.

When ordering, always specify Part Number, Description and Serial Number of Aircraft



PIPER PARTS CATALOG

Figure and Index Number	Part Number	Code	NOMENCLATURE	No. Req.	SERIAL NUMBERS AFFECTED
24-53	400 109		BOLT - (AN4-14)	1	
	407 565		WASHER - (AN960-416)	1	
	404 101		NUT - (AN310-4)	1	
	424 051		PIN - Cotter (AN380-2-2)	1	
-54	14976-17		BUSHING	1	
-55	23956-00		BLANKET ASSEMBLY - Nose wheel well	1	
-56	401 311		BOLT - (AN4-11A)	2	
	407 565		WASHER - (AN960-416)	2	
-57	404 888		NUT - (MS20365-428C)	2	
	400 227		BOLT - (AN6-34)	1	
	407 567		WASHER - (AN960-616)	1	
	404 103		NUT - (AN310-6)	1	
	424 059		COTTER PIN - (MS24665-283)	1	

When ordering, always specify Part Number, Description and Serial Number of Aircraft

# PIPER PARTS CATALOG

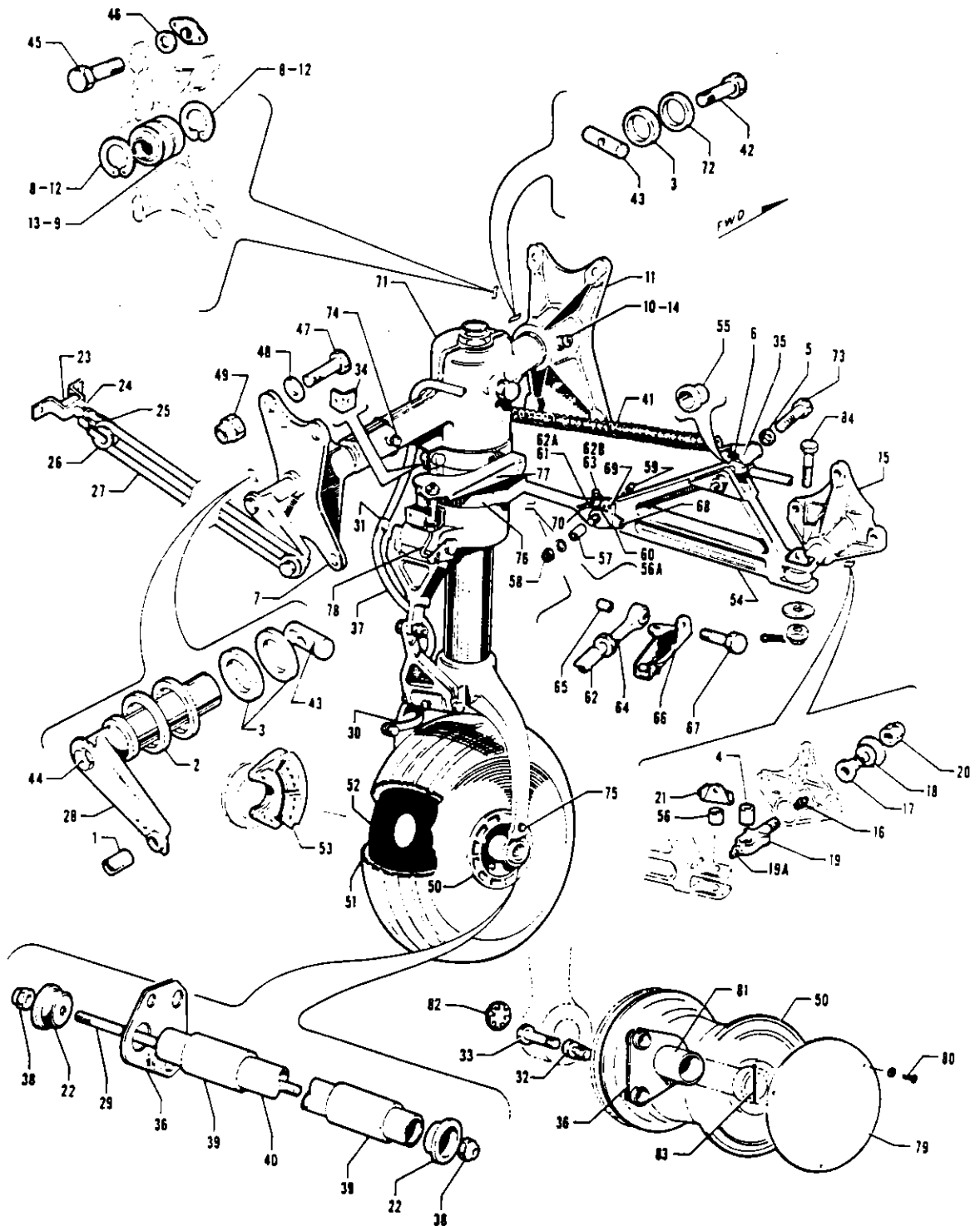

Figure 25. Main Landing Gear Installation

PIPER PARTS CATALOG

Figure and Index Number	Part Number	Code	NOMENCLATURE	No. Req.	SERIAL NUMBERS AFFECTED
25-	23679 25293	Y YZ	DRAWING - Main Landing Gear Installation DRAWING - Main Landing Gear Installation		30-2 to 30-845 inclusive 30-846 and up, 39-1 and up
-1	14175-50		BUSHING	2	
-2	14843-20		BUSHING - Shim (.125)	1	
-3	14843-20		BUSHING - Shim (.125)	AR	
	14843-93		BUSHING - Shim (.062)	AR	
	19513-10		WASHER - Shim (.035)	AR	
-4	14843-30		BUSHING	2	
-5	14843-69		BUSHING	2	
-6	14843-79		BUSHING	2	
-7	20393-00		FITTING ASSEMBLY - Main gear left rear attachment	1	
	20394-00		FITTING ASSEMBLY - Main gear right rear attachment	1	
-8	484 719		* RING - Retaining (5008-175)	2	
-9	452 575	V	* BEARING - Special (PS10020-10-2)	1	
-10	460 691		* FITTING - Lubricator (AN944-101)	1	
-11	20757-00		FITTING ASSEMBLY - Main gear forward attachment, left	1	
	20757-01		FITTING ASSEMBLY - Main gear forward attachment, right	1	
-12	484 719		* RING - Retaining (5008-175)	2	
-13	452 575	V	* BEARING - Special (PS10020-10-2)	1	
-14	460 691		* FITTING - Lubricator (AN944-101)	1	
-15	22513-00		FITTING ASSEMBLY - Main gear side brace support, left	1	
	22513-01		FITTING ASSEMBLY - Main gear side brace support, right	1	
-16	460 691		* FITTING - Lubricator (AN944-101)	1	
-17	20737-13		* BUSHING	1	
-18	20737-14		* BUSHING	1	
-19	22512-00		* STUD - Main gear side brace	1	
-19a	460 687		* * FITTING - Lubricator (1736)	1	
-20	404 398		* NUT - (AN320-9)	1	
-21	21206-00		BRACKET - Wire support, left	1	
	21206-01		BRACKET - Wire support, right	1	
-22	20825-00	Y	PLUG - Wheel end	2	30-2 to 30-845 inclusive
-23	20844-00		NUT - Bungee roller bracker attachment	2	
-24	401 054		BOLT - (3/8 x 1-1/4)	1	
-25	20845-00		BRACKET - Bungee roller	1	
-26	18081-00		ROLLER	2	
-27	31322-07		CORD - Shock, main gear bungee	1	
-28	20846-06		ARM ASSEMBLY - Landing gear bungee, left	1	
	20846-07		ARM ASSEMBLY - Landing gear bungee, right	1	
-29	20854-00	Y	ROD - Wheel axle tie	1	30-2 to 30-845 inclusive
-30	21060-00	Y	CLAMP - Lower brake hose, lower	1	30-2 to 30-845 inclusive
	25449-00	YZ	CLAMP - Lower brake hose, lower	1	30-846 and up, 39-1 and up
-31	21100-00		CLAMP ASSEMBLY - Lower brake hose, upper	2	
-32	80122-86	YZ	WASHER	12	30-846 and up, 39-1 and up
-33	400 019	YZ	BOLT - (AN4-26A)	6	30-846 and up, 39-1 and up
	404 888	YZ	NUT - (MS20365-428C)	6	30-846 and up, 39-1 and up
-34	24750-00	YZ	BRACKET - Brake line support, right	1	30-846 and up, 39-1 and up
-35	21178-00		SWIVEL ASSEMBLY - Side brace spring attachment	2	

V - These parts must be ordered from Service Spares Department, Piper Aircraft Corporation, Vero Beach, Florida.  
Y - Used on PA-30 airplanes only.  
Z - Used on PA-39 airplanes only.

When ordering, always specify Part Number, Description and Serial Number of Aircraft

PIPER PARTS CATALOG

Figure and Index Number	Part Number	Code	NOMENCLATURE	No. Req.	SERIAL NUMBERS AFFECTED
25-36	20824-03	Y	PLATE ASSEMBLY - Brake torque, right	1	30-2 to 30-845 inclusive
	20824-04	Y	PLATE ASSEMBLY - Brake torque, left	1	30-2 to 30-845 inclusive
	451 782	YZ	PLATE ASSEMBLY - Brake torque ( 75-29)	2	30-846 and up, 39-1 and up
-37	17766-73	Y	HOSE ASSEMBLY - Brake, lower	1	30-2 to 30-845 inclusive
	17766-71	YZ	HOSE ASSEMBLY - Brake, lower	1	30-846 and up, 39-1 and up
-38	404 838	Y	NUT - Axle (MS20364-624C)	2	30-2 to 30-845 inclusive
-39	61402-58	Y	BUSHING - Wheel	1	30-2 to 30-845 inclusive
	61402-59	Y	BUSHING - Wheel	1	30-2 to 30-845 inclusive
-40	86062-86	Y	AXLE - Landing gear wheel	1	30-2 to 30-845 inclusive
-41	83302-40		SPRING - Coil	1	
-42	400 014		BOLT - (AN4-21A)	1	
-43	406 660		NUT - Barrel ( 1452-048)	2	
-44	401 346		BOLT - (AN4-54A)	1	
-45	401 187		BOLT - (AN5-7A)	4	
-46	407 586		WASHER - (AN960-516L)	4	
-47	400 004		BOLT - (AN4-7A)	4	
-48	407 585		WASHER - (AN960-416L)	8	
-49	404 888		NUT - (MS20365-428C)	4	
-50	451 779	YZ	WHEEL ASSEMBLY - ( 40-34)	1	30-2 to 30-845 inclusive
	551 752	AYZ	WHEEL ASSEMBLY - ( 40-90)	1	30-846 and up, 39-1 and up
-51	451 724		TIRE - (6.00 x 6 - 6 ply) Type III McCreary	2	
	761 972		TIRE - (6.00 x 6 - 6 ply) B. F. Goodrich	2	
	761 995		TIRE - (6.00 x 6 - 6 ply) McCreary Airhawk	2	
	762 033		TIRE - (6.00 x 6 - 6 ply) Goodyear Flight Custom II	2	
-52	451 735		TUBE - (6.00 x 6)	2	
-53	551 702	A	BRAKE ASSEMBLY - Main ( 30-23)	1	
-54	20767-00	Y	LINK ASSEMBLY - Main gear side brace, upper	1	30-2 to 30-694 inclusive
	20767-04	YZ	LINK ASSEMBLY - Main gear side brace, upper, left	1	30-695 and up, 39-1 and up
	20767-03	YZ	LINK ASSEMBLY - Main gear side brace, upper, right	1	30-695 and up, 39-1 and up
-55	20737-08		* BUSHING	2	
-56	14843-16		* BUSHING	2	
-56a	24912-00	YZ	* BRACKET - Main gear limit switch, left	1	30-695 and up, 39-1 and up
	24912-01	YZ	* BRACKET - Main gear limit switch, right	1	30-695 and up, 39-1 and up
-57	14843-60		BUSHING	1	
-58	400 757		BOLT - (AN26-21)	1	
	407 587		WASHER - (AN960-616L)	1	
	404 395		NUT - (AN320-6)	1	
	424 059		PIN - Cotter (AN380-3-3)	1	
-59	14175-35	Y	BUSHING	1	30-2 to 30-694 inclusive
	14175-103	YZ	BUSHING	2	30-695 and up, 39-1 and up
-60	21103-00	Y	BRACKET - Main gear switch actuating, left	1	30-2 to 30-694 inclusive
	21103-01	Y	BRACKET - Main gear switch actuating, right	1	30-2 to 30-694 inclusive
-61	21104-00	Y	PLATE - Main gear switch actuator, LH	1	30-2 to 30-694 inclusive
	21104-01	Y	PLATE - Main gear switch actuator, RH	1	30-2 to 30-694 inclusive
-62	22577-00	Y	LINK ASSEMBLY - Main gear side brace, lower	1	30-2 to 30-694 inclusive
	25046-00	YZ	LINK ASSEMBLY - Main gear side brace, lower	1	30-695 and up, 39-1 and up
-62a	24915-00	YZ	* BRACKET - Main gear limit switch	1	30-695 and up, 39-1 and up
-62b	460 860	YZ	* FITTING - (MS15001-2)	1	30-695 and up, 39-1 and up
-63	460 691	Y	FITTING - (AN944-101)	1	30-2 to 30-694 inclusive
-64	22943-00		BEARING ASSEMBLY - Rod end	1	
-65	19513-56		WASHER	2	
-66	22825-00	Y	BRACKET ASSEMBLY - Main gear door retraction, LH	1	30-2 to 30-694 inclusive
	22825-01	Y	BRACKET ASSEMBLY - Main gear door retraction, RH	1	30-2 to 30-694 inclusive
	24819-00	YZ	BRACKET ASSEMBLY - Main gear door retraction, LH	1	30-695 and up, 39-1 and up
	24819-01	YZ	BRACKET ASSEMBLY - Main gear door retraction, RH	1	30-695 and up, 39-1 and up

A - See Figure 27 for component parts.  
Y - Used on PA-30 airplanes only.  
Z - Used on PA-39 airplanes only.

When ordering, always specify Part Number, Description and Serial Number of Aircraft

PIPER PARTS CATALOG

Figure and Index Number	Part Number	Code	NOMENCLATURE	No. Req.	SERIAL NUMBERS AFFECTED
25-67	400 368		BOLT - (AN9-35)	1	
	407 570		WASHER - (AN960-916)	1	
	404 913		NUT - (MS20365-918C)	1	
-68	415 457		SCREW - (AN526-832R-22)	1	
	404 833		NUT - (MS20364-832C)	1	
-69	414 722		SCREW - (AN507-832R-20)	1	
	404 833		NUT - (MS20364-832C)	1	
-70	415 742		SCREW - (AN515-6R14)	1	
	404 829		NUT - (MS20364-632C)	1	
-71	22833-02	AY	STRUT ASSEMBLY - Main gear, left	1	30-2 to 30-845 inclusive
	27142-00	AYZ	STRUT ASSEMBLY - Main gear, left	1	30-846 and up, 39-1 and up
	22833-03	AY	STRUT ASSEMBLY - Main gear, right	1	30-2 to 30-845 inclusive
	24681-05	AYZ	STRUT ASSEMBLY - Main gear, right	1	30-846 and up, 39-1 and up
-72	80122-91		WASHER	1	
-73	400 016		BOLT - (AN4-24A)	1	
	407 565		WASHER - (AN960-416)	1	
	404 888		NUT - (MS20365-428C)	1	
-74	20828-00		STUD	2	
-75	402 352	Y	BOLT - (AN176-13A)	1	30-2 to 30-845 inclusive
	407 567	Y	WASHER - (AN960-616)	1	30-2 to 30-845 inclusive
	404 890	Y	NUT - (MS20365-624C)	1	30-2 to 30-845 inclusive
-76	21221-00	Y	BRACKET - Gear safety switch mounting, left	1	30-2 to 30-694 inclusive
	24773-00	YZ	BRACKET ASSEMBLY - Gear safety switch mounting, left	1	30-695 and up, 39-1 and up
-77	21220-00	Y	ARM - Gear actuator, left	1	30-2 to 30-694 inclusive
-78	21219-00	Y	ROD - Gear safety switch actuating, left	1	30-2 to 30-694 inclusive
-79	24918-00	YZ	COVER - Wheel	1	30-846 and up, 39-1 and up
-80	415 445	YZ	SCREW - (AN526-8R4)	3	30-846 and up, 39-1 and up
	407 128	YZ	LOCK WASHER - (AN936-B10)	3	30-846 and up, 39-1 and up
-81	86062-102	YZ	BUSHING - Wheel	1	30-846 and up, 39-1 and up
-82	453 639	YZ	BUTTON - Plug (HS-50726)	1	30-846 and up, 39-1 and up
-83	424 071	YZ	PIN - Cotter (AN380-4-8)	1	30-846 and up, 39-1 and up
-84	400 761		BOLT - (AN26-25)	2	
	407 587		WASHER - (AN960-616L)	2	
	404 395		NUT - (AN320-6)	2	
	424 059		COTTER PIN - (MS24665-283)	2	

A - See Figure 26 for component parts  
 Y - Used on PA-30 airplanes only.  
 Z - Used on PA-39 airplanes only.

When ordering, always specify Part Number, Description and Serial Number of Aircraft

**1 H14**  
**INTENTIONALLY LEFT BLANK**

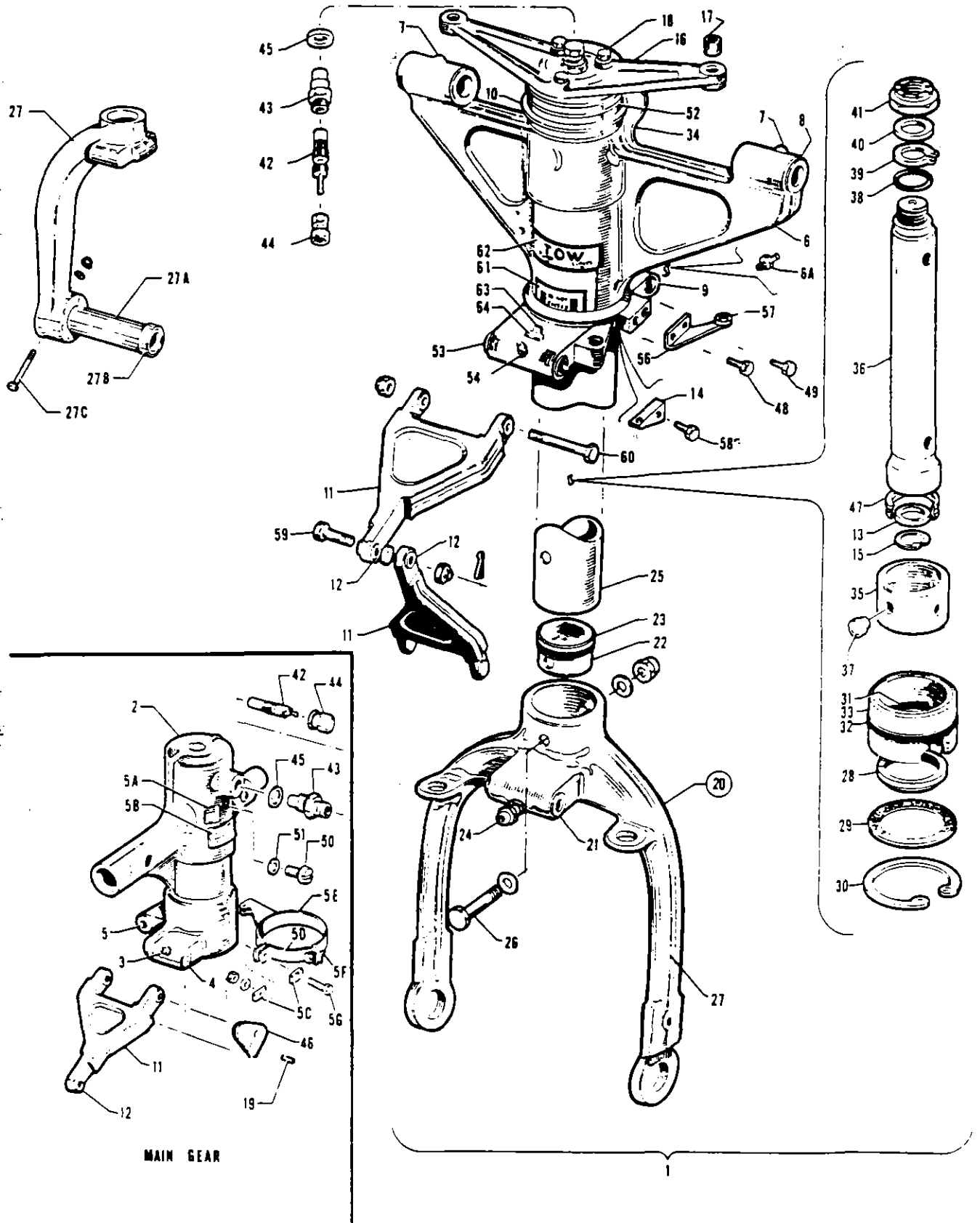

Figure 2c. Landing Gear Strut Assemblies



Figure and Index Number	Part Number	Code	NOMENCLATURE	No. Req.	SERIAL NUMBERS AFFECTED
26-	22833 24681 22810	Y YZ	DRAWING - Main Landing Gear Strut DRAWING - Main Landing Gear Strut DRAWING - Nose Landing Gear Strut		30-2 to 30-845 inclusive 30-846 and up, 39-1 and up
-1	22833-02 27142-00 22833-03 24681-05 22810-00 22810-03	Y YZ Y YZ C	STRUT ASSEMBLY - Main gear, left STRUT ASSEMBLY - Main gear, left STRUT ASSEMBLY - Main gear, right STRUT ASSEMBLY - Main gear, right STRUT ASSEMBLY - Nose gear STRUT ASSEMBLY - Nose gear	1 1 1 1 1 1	30-2 to 30-845 inclusive 30-846 and up 39-1 and up 30-2 to 30-845 inclusive 30-846 and up 39-1 and up 30-2 to 30-1198 inclusive 30-1199 to 30-1716 inclusive 30-1718 to 30-1744 inclusive
-2	22810-04 20752-08 27053-00 20752-09 27053-01	 AB A AB A	STRUT ASSEMBLY - Nose gear HOUSING ASSEMBLY - Main gear strut, LH HOUSING ASSEMBLY - Main gear strut, LH HOUSING ASSEMBLY - Main gear strut, RH HOUSING ASSEMBLY - Main gear strut, RH	1 1 1 1 1	30-1717, 30-1745 and up 30-2 and up, 39-1 to 39-135 39-136 and up 30-2 and up, 39-1 to 39-135 39-136 and up
-3	460 690	A	FITTING - Lubricator (AN944-201A)	1	
-4	20737-02	A	BUSHING	2	
-5	20737-16	A	BUSHING	1	
-5a	21588-00		PLACARD - Oil level (481 003)	1	
-5b	27260-02		PLACARD - Strut oleo service	1	
-5c	21173-00	A	SPACER - Spring attachment	1	30-2 and up, 39-1 to 39-135
-5d	21174-00 27055-00	AB A	STRAP - Main gear spring attachment STRAP - Main gear spring attachment	1 1	30-2 and up, 39-1 to 39-135 39-136 and up
-5e	21175-00  27056-00  21175-01  27056-01	AB  A  AB  A	BRACKET ASSEMBLY - Main gear spring attachment, left  BRACKET ASSEMBLY - Main gear spring attachment, left  BRACKET ASSEMBLY - Main gear spring attachment, right  BRACKET ASSEMBLY - Main gear spring attachment, right	1  1  1  1	30-2 and up, 39-1 to 39-135  39-136 and up  30-2 and up, 39-1 to 39-135  39-136 and up
-5f	400 440 407 584 404 835	A A A	BOLT - (AN3-6A) WASHER - (AN960-10L) NUT - (MS20364-1032C)	1 1 1	39-136 and up 39-136 and up 39-136 and up
-5g	401 269 407 584 404 835	A A A	BOLT - (AN3-10A) WASHER - (AN960-10L) NUT - (MS20364-1032C)	1 1 1	39-136 and up 39-136 and up 39-136 and up

A - Used on main gear strut only.  
 B - Order part for serial numbers 39-136 and up if Piper Part No. 27016 (left strut) or 27016-01 (right strut) is forged on landing gear strut housing.  
 C - Order part for serial numbers 30-1199 to 30-1716 inclusive, 30-1718 to 30-1744 inclusive if shimmy dampener incorporates a self-aligning end bearing.  
 Y - Used on PA-30 airplanes only.  
 Z - Used on PA-39 airplanes only.

When ordering, always specify Part Number, Description and Serial Number of Aircraft





Figure and Index Number	Part Number	Code	NOMENCLATURE	No. Req.	SERIAL NUMBERS AFFECTED
26-6	21715-04	BY	HOUSING ASSEMBLY - Nose gear strut	1	30-2 to 30-1716 inclusive, 30-1718 to 30-1744 inclusive
	21715-06	BC	HOUSING ASSEMBLY - Nose gear strut	1	
-6a	460 690	BY	FITTING - Lubricator (AN944-201A)	1	30-2 to 30-1716 inclusive, 30-1718 to 30-1744 inclusive
	460 691	BC	FITTING - Lubricator (AN944-101)	1	
-7	460 691	B	FITTING - Lubricator (AN944-101)	3	
-8	31766-00	B	BUSHING - Nose gear strut	2	
-9	20737-04	B	BUSHING - Nose gear strut	2	
-10	21706-00	B	BUSHING - Nose gear strut	2	
-11	20735-00	A	LINK ASSEMBLY - Main gear torque	2	
	20735-00	B	LINK ASSEMBLY - Nose gear torque	2	
-12	452 366		BEARING - Oilite (F-310-5)	1	
-13	20782-02		PLATE - Landing gear strut orifice	1	
-14	21829-00	B	LUG - Nose gear spring front attachment, right	1	
	21829-01	BCD	LUG - Nose gear spring front attachment, left	1	
-15	484 717		RING - Snap (5000-118)	1	
-16	44386-00	B	ARM ASSEMBLY - Nose wheel steering	1	
-17	14976-11	B	BUSHING	2	
-18	402 800	B	BOLT - (NAS1303-8H)	3	
	407 564	B	WASHER - (AN960-10)	3	
-19	480 687	AY	PIN - Roll (59-012-062-0250)	1	30-2 to 30-694 inclusive
	419 600	AYZ	SCREW - Round head drive (AN535-2-4)	1	30-695 and up, 39-1 and up
-20	20790-02	B	FORK ASSEMBLY - Nose gear	1	
	20790-02	AY	FORK ASSEMBLY - Main gear, left and right	1	30-2 to 30-845 inclusive
	24680-00	AYZ	FORK ASSEMBLY - Main gear, left	1	30-846 and up, 39-1 and up
	24680-01	AYZ	FORK ASSEMBLY - Main gear, right	1	30-846 and up, 39-1 and up
-21	20737-02		BUSHING - Landing gear fork	2	
-22	20787-00		PLUG - Landing gear fork	1	
-23	484 711		PACKING - "O" Ring (AN6227-23)	1	
-24	460 690		FITTING - Lubricator (AN944-201A)	1	
-25	22785-00		TUBE - Landing gear strut piston	1	
-26	402 325		BOLT - (AN174-27A)	1	
	404 888		NUT - (MS20365-428C)	1	
	407 585		WASHER - (AN960-416L)	2	
-27	20736-02	B	FORK - Nose gear	1	
	20736-02	AY	FORK - Main gear, left and right	1	30-2 to 30-845 inclusive
	24679-00	AYZ	FORK - Main gear, left	1	30-846 and up, 39-1 and up
	24679-01	AYZ	FORK - Main gear, right	1	30-846 and up, 39-1 and up
-27a	24678-00	AYZ	AXLE - Main gear	1	30-846 and up, 39-1 and up
-27b	24677-00	AYZ	NUT - Main gear axle	1	30-846 and up, 39-1 and up
-27c	401 329	AYZ	BOLT - (AN4-13A)	1	30-846 and up, 39-1 and up
	407 585	AYZ	WASHER - (AN960-416L)	1	30-846 and up, 39-1 and up
	404 836	AYZ	NUT - (MS20364-428C)	1	30-846 and up, 39-1 and up

A - Used on main gear strut only.  
 B - Used on nose gear strut only.  
 C - Used on PA-30 with serial numbers 30-1717, 30-1745 and up, and PA-39 with serial numbers 39-1 and up.  
 D - Used on PA-30 with serial numbers 30-2 to 30-1716, 30-1718 to 30-1744 inclusive if Landing Gear Emergency Extension Security Installation Kit 760 627 has been installed per Service Spares Letter SP-325 or Nose Gear Down Lock Spring Installation Kit 760 082 has been installed per Service Letter 782.  
 Y - Used on PA-30 airplanes only.  
 Z - Used on PA-39 airplanes only.

When ordering, always specify Part Number, Description and Serial Number of Aircraft



Figure and Index Number	Part Number	Code	NOMENCLATURE	No. Req.	SERIAL NUMBERS AFFECTED
26-28	187 625	E	STRIP - Wiper (10V70) (5-7/8" L)		
-29	19513-39		WASHER	1	
-30	484 718		RING - Snap (5000-250)	1	
-31	484 734		PACKING - "O" Ring (AN6227-31)	1	
-32	462 034		GASKET - "O" Ring (AN6230-5)	1	
-33	22775-00		BEARING - Landing gear strut tube bearing	1	
-34	21719-11	B	BRACKET ASSEMBLY - Nose gear aligner guide	1	
-35	20785-02		BEARING - Landing gear strut tube, upper	1	
-36	20754-02	A	TUBE - Landing gear strut orifice	1	
	21712-02	B	TUBE - Landing gear strut orifice	1	
-37	20784-00		PIN - Bearing retainer	4	
-38	484 712		PACKING - "O" Ring (752 713) (AN6227-15)	1	
-39	484 714	A	RING - Back-up (MS28782-15)	1	
	484 723	B	RING - Snap (5100-268)	1	
-40	80122-89	A	WASHER	1	
	21710-00	B	WASHER	1	
-41	752 483	A	NUT - (AN364-1216)	1	
	404 840	B	NUT - (AN364-1414)	1	
-42	455 124		CORE - Air valve (AN809-1)	1	
-43	453 124		BODY - Air valve (AN812-1)	1	
-44	454 053		CAP - Air valve (AN813-1B)	1	
-45	751 834		GASKET - Air valve (AN901-5A)	1	
-46	21215-00	AY	BRACKET - Gear switch actuating rod, left	1	30-2 to 30-694 inclusive
	24775-00	AYZ	BRACKET - Gear switch actuating rod, right	1	30-695 and up, 39-1 and up
-47	484 826		RING - Compression	1	
-48	401 263		BOLT - Shimmy dampener attachment (AN3H-3A)	1	
-49	401 264		BOLT - Shimmy dampener attachment (AN3H-4A)	1	
-50	21587-00	A	BOLT - Oleo bleeder hole	1	
-51	753 172	A	WASHER - Oleo bleeder bolt (21586-00)	1	
-52	21707-00	B	TUBE ASSEMBLY - Nose gear strut, upper	1	
-53	20737-02	B	BUSHING	1	
-54	460 691	B	FITTING - Lubricator (AN944-101)	1	
-55	21831-04	B	BEARING - (F248A)	1	
-56	21709-00	BDY	BRACKET ASSEMBLY - Shimmy dampener attachment	1	30-2 to 30-1198 inclusive
	25666-00	BYZ	BRACKET - Shimmy dampener attachment	1	30-1199 and up, 39-1 and up
-57	21831-03	Y	BEARING - Shimmy dampener bracket	1	30-2 to 30-1198 inclusive
-58	400 438	BY	BOLT - (AN3-4A)	1	30-2 to 30-1716 inclusive, 30-1718 to 30-1744 inclusive
	400 438	BC	BOLT - (AN3-4A)	2	
	407 135	BY	WASHER - (AN936-A10)	1	30-2 to 30-1716 inclusive, 30-1718 to 30-1744 inclusive
	407 135	BC	WASHER - (AN936-A10)	2	

A - Used on main gear strut only.  
 B - Used on nose gear strut only.  
 C - Used on PA-30 with serial numbers 30-1717, 30-1745 and up, and PA-39 with serial numbers 39-1 and up.  
 D - Order part for PA-30 with serial numbers 30-1199 and up if shimmy dampener incorporates a self aligning end bearing.  
 E - Sold by foot length.  
 Y - Used on PA-30 airplanes only.  
 Z - Used on PA-39 airplanes only.

When ordering, always specify Part Number, Description and Serial Number of Aircraft



Figure and Index Number	Part Number	Code	NOMENCLATURE	No. Req	SERIAL NUMBERS AFFECTED
26-39	402 313		BOLT - Torque link assembly joint (AN174-13)	1	
	404 101		NUT - Torque link assembly joint (AN310-4)	1	
	424 052		PIN - Torque link assembly joint (MS24665-134)	1	
	407 565		WASHER - Torque link assembly joint (AN960-416)	2	
	407 565		WASHER - Torque link assembly joint center (AN960-416L)	1	
-60	402 344		BOLT - Torque link assembly (AN175-32)	2	
	404 102		NUT - Torque link assembly (AN310-5)	2	
	407 586		WASHER - Torque link assembly (AN960-516L)	4	
	424 052		PIN - (MS24665-134)	2	
-61	27257-00	A	PLACARD - Do not exceed	1	
-62	27258-00	A	PLACARD - Tow turn limits	1	
-63	42740-00	A	INDICATOR - Tow turn	1	
-64	419 600	A	SCREW - (MS21316-15)	2	

A - Used on nose gear strut only.

When ordering, always specify Part Number, Description and Serial Number of Aircraft

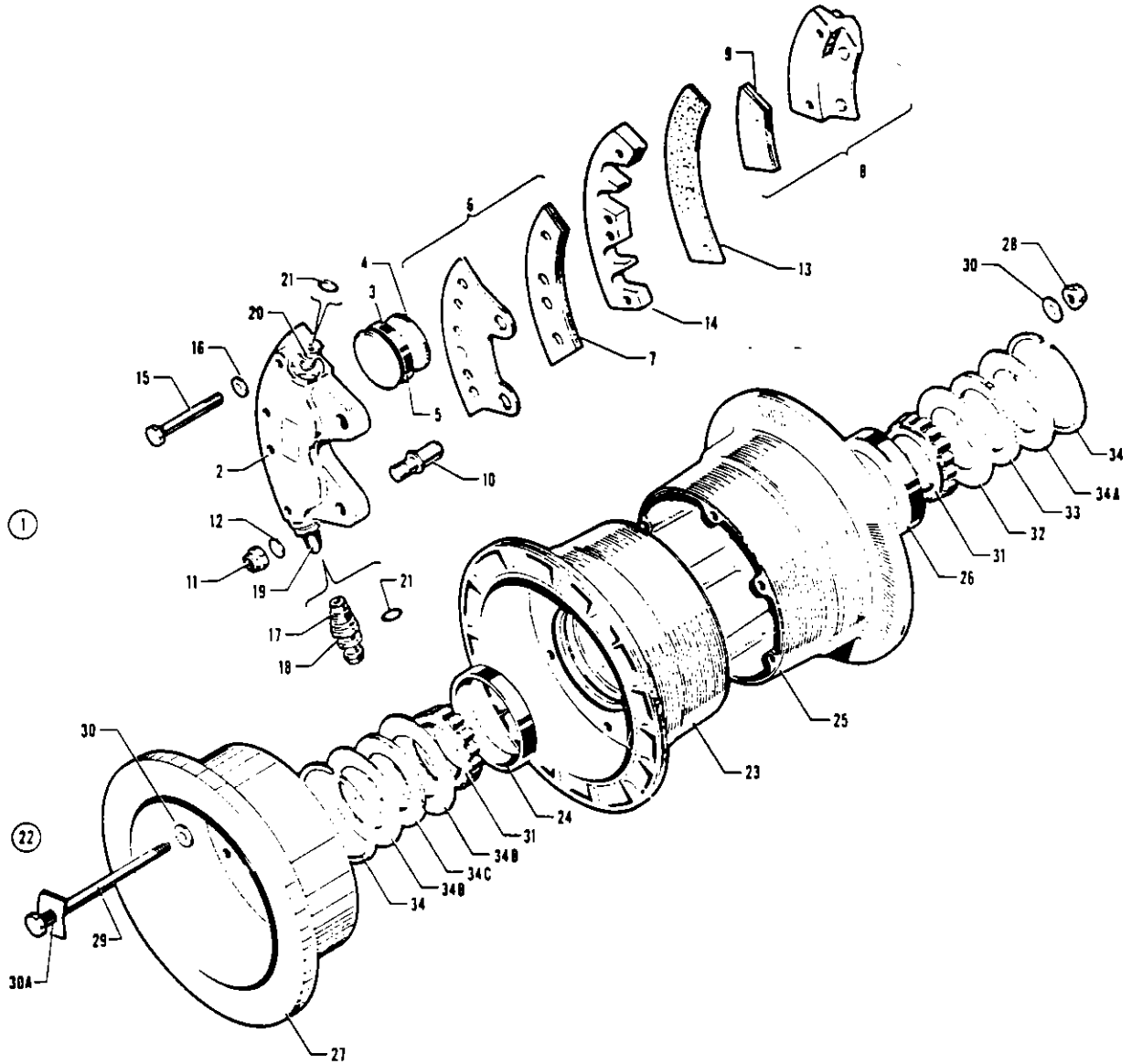

Figure 27. Main Wheel and Brake Assembly



Figure and Index Number	Part Number	Code	NOMENCLATURE	No. Req.	SERIAL NUMBERS AFFECTED
27-1	551 702		BRAKE ASSEMBLY - (30-23)	2	
-2	753 874		CYLINDER - (61-10)	1	
-3	755 838		PISTON - (62-7)	2	
-4	752 094		INSULATOR - (88-1)	2	
-5	484 698		"O" RING - (AN6227-27)	2	
-6	755 839		PRESSURE PLATE ASSEMBLY - (73-6)	1	
-7	752 335		LINING - (66-15)	1	
-8	755 840		BACK PLATE ASSEMBLY - (74-6)	2	
-9	752 336		LINING - (66-19)	1	
-10	751 402		BOLT - Anchor (3013)	2	
-11	404 838		NUT	2	
-12	407 587		WASHER - (AN960-616L)	2	
-13	756 147		SHIM - Back plate (68-11)	1	
-14	756 148		SHIM - Back plate (68-12)	1	
-15	751 468		BOLT - (AN4H-16A)	4	
-16	407 585		WASHER - (AN960-416L)	4	
-17	756 149		SEAT - Bleeder (81-2)	1	
-18	752 965		SCREW - Bleeder (FC-6446)	1	
-19	753 850		CAP - Bleeder (183-1)	1	
-20	491 050		FITTING - Tube (AN815-4D)	1	
-21	484 701		"O" RING - Packing (AN6227-7)	2	
-22	451 779	Y	WHEEL ASSEMBLY - Main (40-34)	2	30-2 to 30-845 inclusive
	551 752	YZ	WHEEL ASSEMBLY - Main (40-90)	2	30-846 and up, 39-1 and up
-23	753 191	AY	WHEEL - Half, inner (161-21)	1	30-2 to 30-845 inclusive
	753 195	BYZ	WHEEL - Half, inner (161-30)	1	30-846 and up, 39-1 and up
-24	751 494		CUP - Searing (13836)	1	
-25	753 192	AY	WHEEL - Half, outer (162-19)	1	30-2 to 30-845 inclusive
	753 194	BYZ	WHEEL - Half, outer (162-27)	1	30-846 and up, 39-1 and up
-26	751 494		CUP - Searing (13836)	1	
-27	754 531	AY	BRAKE DISC ASSEMBLY - (164-10)	1	30-2 to 30-845 inclusive
	754 554	BYZ	BRAKE DISC ASSEMBLY - (164-22A)	1	30-846 and up, 39-1 and up
-28	404 888	AY	NUT - (AN365-428)	6	30-2 to 30-845 inclusive
	404 889	BYZ	NUT - (AN365-524)	3	30-846 and up, 39-1 and up
-29	401 335	AY	BOLT - (AN4-40A)	6	30-2 to 30-845 inclusive
	753 473	BCYZ	BOLT - (AN5-36A)	3	30-846 and up, 39-1 and up
-30	407 565	AY	WASHER - (AN960-416)	12	30-2 to 30-845 inclusive
	407 566	BCYZ	WASHER - (AN960-516)	A.R.	30-846 and up, 39-1 and up
-30a	756 609	BD	WASHER - (95-8)	3	

A - Used with No. 40-34 Main Wheel Assembly only.  
 B - Used with No. 40-90 Main Wheel Assembly only.  
 C - If brake disc is stamped with Cleveland No. 164-22A or if bolt hole is spot-faced, (2) washers Part No. 407 566 must be installed under each bolt head and (1) washer Part No. 407 566 must be installed under each nut. If brake disc is not stamped with Cleveland No. 164-22A and bolt hole is not spot-faced, (1) washer Part No. 756 609 must be installed under each bolt head and (1) washer Part No. 407 566 must be installed under each nut.  
 D - One (1) washer used under each bolt head if brake disc is not stamped with Cleveland No. 164-22A and bolt hole is not spot-faced.  
 Y - Used on PA-30 airplanes only.  
 Z - Used on PA-39 airplanes only.

When ordering, always specify Part Number, Description and Serial Number of Aircraft



Figure and Index Number	Part Number	Code	NOMENCLATURE	No. Req.	SERIAL NUMBERS AFFECTED
27-31	751 489		CONE - Bearing (13889)	2	
-32	752 829	Y	RING - Grease seal (3022)	1	30-2 to 30-845 inclusive
	755 929	BYZ	RING - Grease seal (A39070)	1	30-846 and up, 39-1 and up
-33	751 772	AY	FELT - Grease seal (3021)	1	30-2 to 30-845 inclusive
	751 810	BYZ	FELT - Grease seal (154-13)	1	30-846 and up, 39-1 and up
-34	752 830		SNAP RING - Grease seal (3023)	2	
-34a	752 829	AY	RING - Grease seal (3022)	1	30-2 to 30-845 inclusive
	755 930	BYZ	RING - Grease seal (153-15)	1	30-846 and up, 39-1 and up
-34b	752 829		RING - Grease seal (3022)	2	
-34c	751 772		FELT - Grease seal (3021)	1	

A - Used with No. 40-34 Main Wheel Assembly only.  
 B - Used with No. 40-90 Main Wheel Assembly only.  
 Y - Used on PA-30 airplanes only.  
 Z - Used on PA-39 airplanes only.

When ordering, always specify Part Number, Description and Serial Number of Aircraft

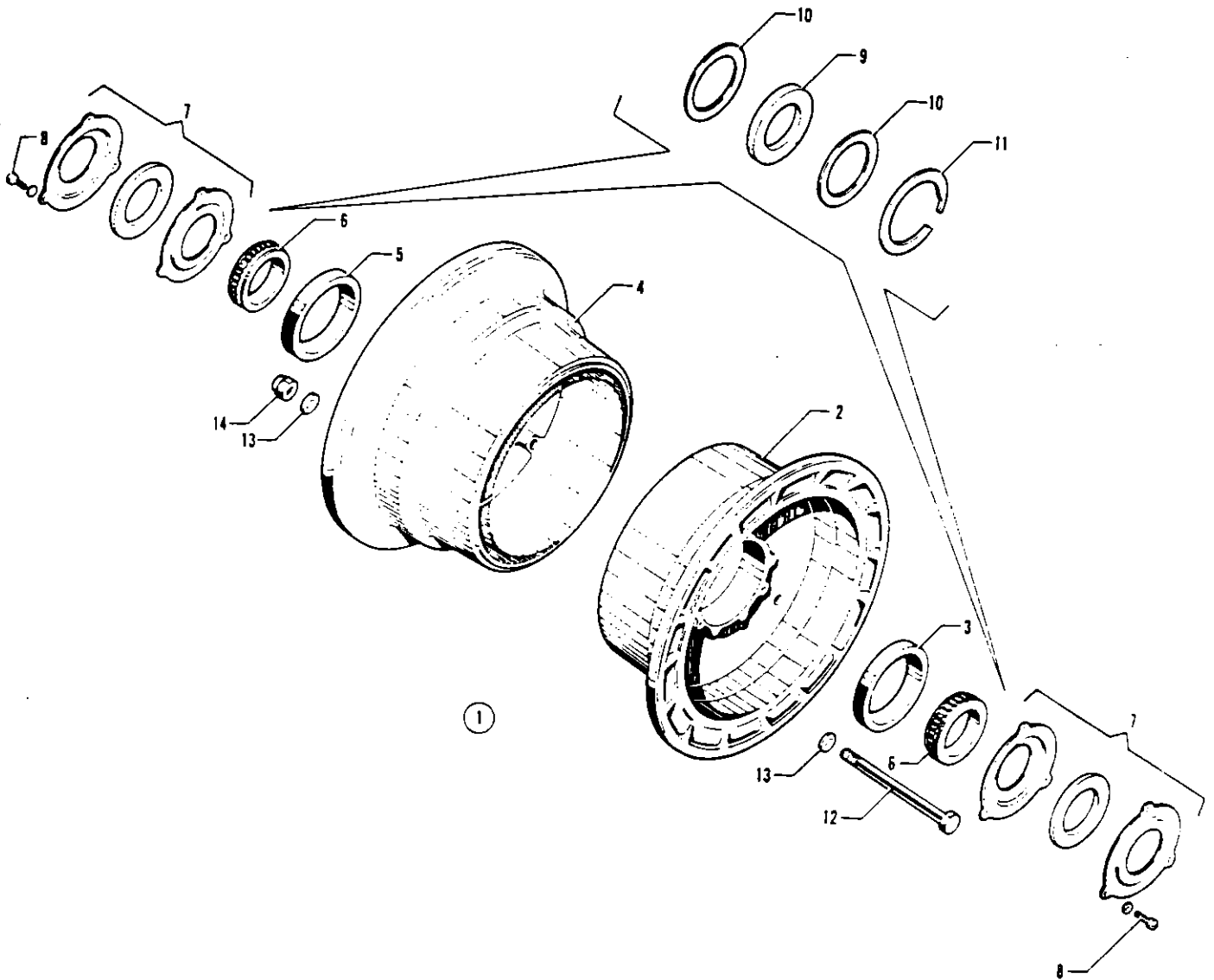

Figure 27A. Nose Wheel Assembly



Figure and Index Number	Part Number	Code	NOMENCLATURE	No. Req.	SERIAL NUMBERS AFFECTED
27A-1	451 755	A	WHEEL ASSEMBLY - Nose (38501)	1	
	451 784	B	WHEEL ASSEMBLY - Nose (40-76B)	1	
-2	753 129	C	WHEEL HALF ASSEMBLY - Inner (3045A)	1	
	753 195	D	WHEEL HALF ASSEMBLY - Inner (161-30)	1	
-3	751 494		CUP - Bearing (13836)	1	
-4	753 128	C	WHEEL HALF ASSEMBLY - Outer (3041-A) (with valve hole)	1	
	753 194	D	WHEEL HALF ASSEMBLY - Outer (162-27) (with valve hole)	1	
-5	751 494		CUP - Bearing (13836)	1	
-6	751 489		BEARING - Cone, Timken (13889)	2	
-7	752 882	C	GREASE SEAL ASSEMBLY - (B39001)	2	
-8	756 129	C	SCREW - (8-32 x 1/2)	6	
	407 134	C	WASHER - (AN936A8)	6	
-9	751 819	D	FELT - Grease seal (154-14)	2	
-10	755 964	D	RING - Grease seal (153-9)	4	
-11	752 830	D	RING - Snap (3023)	2	
-12	401 334	C	BOLT - (AN4-36A)	3	
	751 405	D	BOLT - (AN5-35A)	3	
-13	407 565	C	WASHER - (AN960-416)	6	
	407 566	D	WASHER - (AN960-516)	6	
-14	404 888	C	NUT - (AN365-428)	3	
	404 889	D	NUT - (AN365-524)	3	

A - Used on PA-30 with serial numbers 30-2 to 30-2000 inclusive and PA-39 with serial numbers 39-1 to 39-148 inclusive, 39-150 and 39-151. Part is no longer available. Order Wheel Assembly Part No. 451 784 and two spacer bushings Part No. 31786-03 when replacing Model No. 38501 wheel. Order Part No. 451 784 wheel only if Model No. 40-76B has previously been installed.

B - Used on PA-39 with serial numbers 39-149, 39-152 and up.

C - Used on Model 38501 wheel assembly only.

D - Used on Model 40-76B wheel assembly only.

When ordering, always specify Part Number, Description and Serial Number of Aircraft



1 1 1

INTENTIONALLY LEFT BLANK

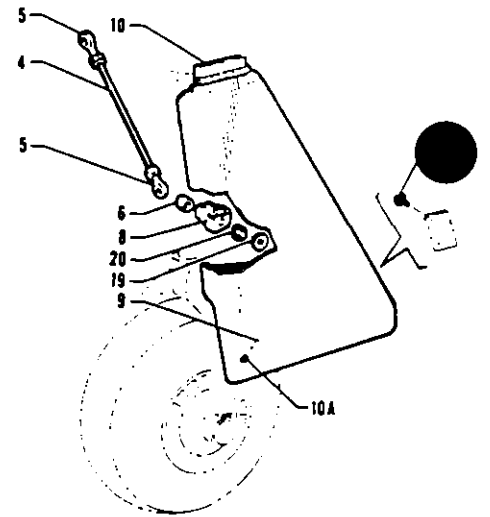
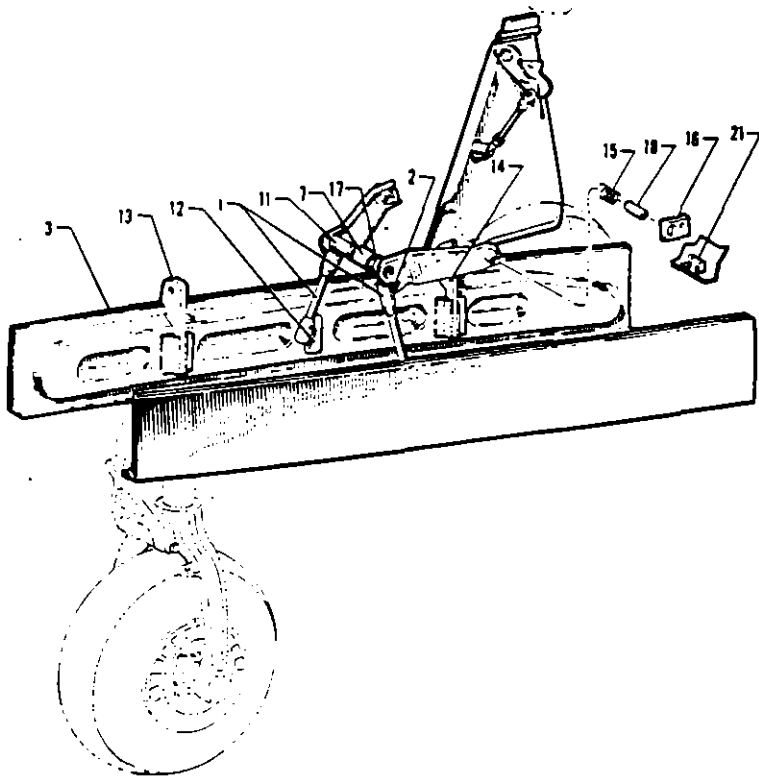

Figure 28. Landing Gear Door Installation



Figure and Index Number	Part Number	Code	NOMENCLATURE	No. Req.	SERIAL NUMBERS AFFECTED
28-	23729		DRAWING - Landing Gear Door Installation		
-1	23787-00		ROD ASSEMBLY - Nose gear door retraction	2	
-2	469 138		JOINT - Ball	2	
-3	23950-00		DOOR ASSEMBLY - Nose gear, LH	1	
	23950-01		DOOR ASSEMBLY - Nose gear, RH	1	
-4	21067-03		ROD ASSEMBLY - Main gear door retraction	2	
-5	452 383		BEARING - (24166-00)	2	
-6	14976-09		BUSHING - Main gear	2	
-7	17794-00		SEGMENT - Fairlead	1	
-8	21066-00		HORN ASSEMBLY - Main gear door retraction	2	
-9	22984-00		DOOR ASSEMBLY - Main gear, left	1	
	22984-01		DOOR ASSEMBLY - Main gear, right	1	
-10	21065-12		HINGE - Landing gear door	1	
-10a	453 646		BUMPER - (#734)	1	
-11	23880-00		LINK ASSEMBLY - Nose gear door actuating	1	
-12	23946-00		BRACKET - Nose gear cover rod attachment	1	
	23946-01		BRACKET - Nose gear cover rod attachment	1	
-13	23974-00		HINGE ASSEMBLY - Nose gear cover, front	2	
-14	23975-00		HINGE ASSEMBLY - Nose gear cover, rear	2	
-15	24033-00		SPRING - Nose gear cover torsion, left	1	
	24033-01		SPRING - Nose gear cover torsion, right	1	
-16	24052-00		SPACER - Nose gear door actuator	1	
-17	40081-00		RING - Fairlead snap	2	
-18	01402-62		BUSHING - Nose gear, left	1	
	01402-63		BUSHING - Nose gear, right	1	
-19	80122-10		WASHER - Main gear	2	
-20	408 816		SPRING - Washer	2	
-21	453 641		BUMPER - Stem	6	

When ordering, always specify Part Number, Description and Serial Number of Aircraft

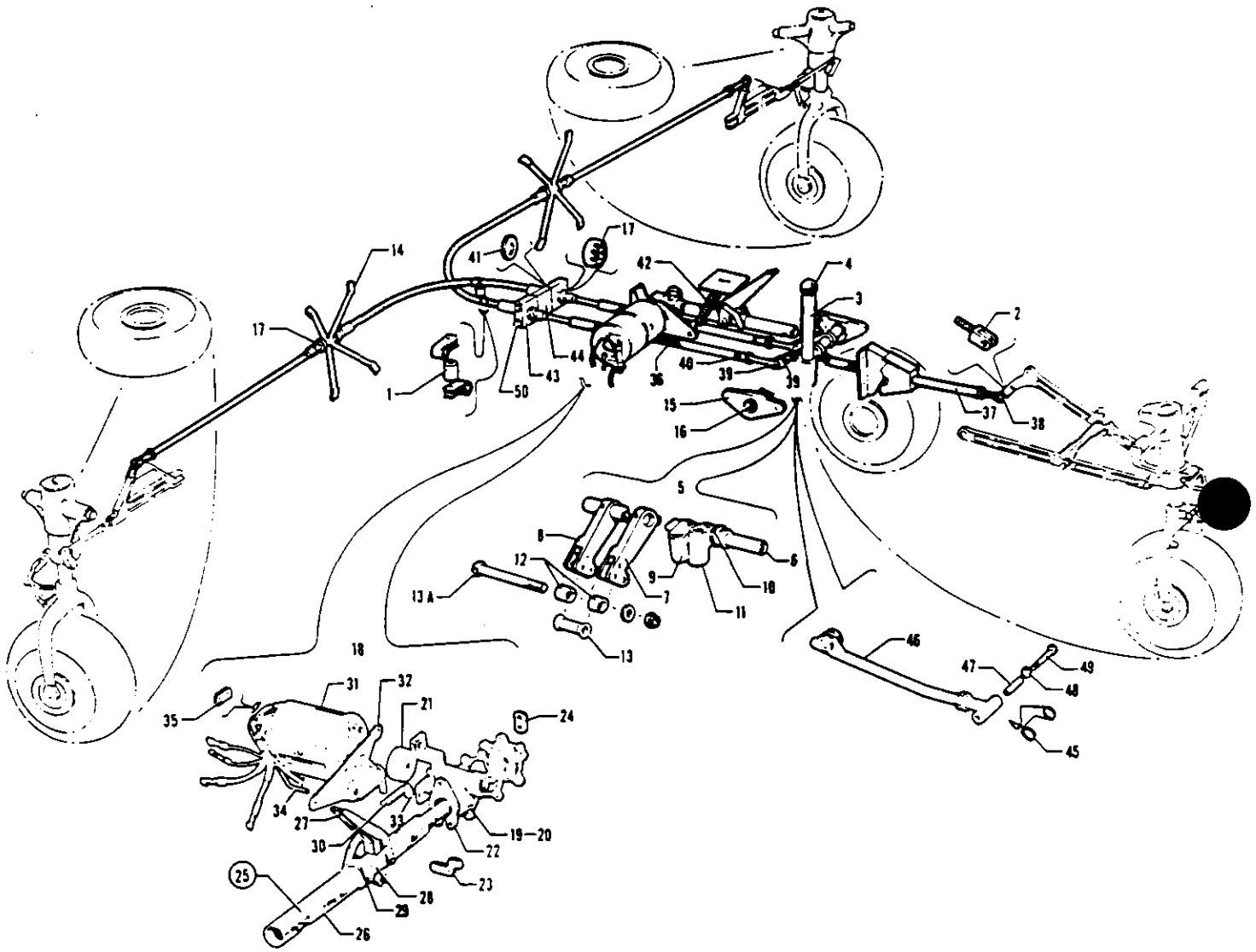

Figure 29. Landing Gear Retraction System

PIPER PARTS CATALOG

Figure and Index Number	Part Number	Code	NOMENCLATURE	No. Req.	SERIAL NUMBERS AFFECTED
29-	23636		DRAWING - Landing Gear Retraction System		
-1	14843-62		BUSHING	1	
-2	23103-00		CLEVIS - Nose gear drag link	1	
-3	23919-00		LEVER ASSEMBLY - Landing gear extension	1	
-4	471 056		* KNOB - Red	1	
-5	23982-00		TUBE ASSEMBLY - Gear retraction torque	1	
-6	23982-02		* TUBE - Gear retraction torque	1	
-7	21012-02	Y	* ARM - Gear retraction tube, outboard	1	30-2 to 30-648 inclusive
	25137-00	AY	* ARM - Gear retraction tube, outboard	1	30-649 and up, 39-1 and up
-8	21012-03		* ARM - Gear retraction tube, inboard	1	
-9	21013-02		* SOCKET - Landing gear retraction lever	1	
-10	23970-00		* SPRING - Landing gear retraction lever	1	
-11	23973-00		* SOCKET - Landing gear retraction lever	1	
-12	14843-88		* BUSHING - Gear retraction torque tube	2	
-13	21087-00		* SPACER - Gear retraction torque tube	1	
-13a	400 939		* BOLT - (AN24-60A)	1	
	407 565		* WASHER - (AN960-416)	1	
	404 836		* NUT - (MS20364-42BC)	1	
-14	21033-00		BRACKET ASSEMBLY - Landing gear control support	2	
-15	21041-00		BRACKET ASSEMBLY - Gear retracting tube	2	
-16	452 373		* BEARING	1	
-17	21063-00		NUT - Retraction push-pull cable	8	
-18	25720-00		TRANSMISSION ASSEMBLY - Landing gear retraction	1	
-19	25720-03	B	* TRANSMISSION ASSEMBLY - (Less motor)	1	
-20	25720-02	B	* * TRANSMISSION ASSEMBLY - (Less motor and release arm)	1	
-21	757 833		* * * COUPLING - Transmission gear retraction	1	
-22	21854-00	AYZ	* * * PLATE - Transmission retainer bearings	1	
-23	24022-00	Y	* * * LINK - Transmission retainer spring	1	30-2 to 30-1448 inclusive
	25719-00	YZ	* * * LINK - Transmission retainer spring	1	30-1449 and up, 39-1 and up
-24	81262-95	AYZ	* * * LINK - Transmission retainer bearing plate support	1	
-25	21855-00		* * ARM ASSEMBLY - Gear retraction motor release	1	
-26	21704-00		* * * TUBE - Landing gear transmission retraction	1	
-27	21083-03		* * * ARM - Motor release	1	
-28	21080-00		* * * LINK	2	
-29	21038-07		* * * BUSHING	1	
-30	83302-42	Y	* SPRING ASSEMBLY - Landing gear transmission brake	1	30-2 to 30-648 inclusive
-31	21286-00		* MOTOR ASSEMBLY - Landing gear transmission retraction	1	
-32	23042-00	Y	* BRAKE AND ARM ASSEMBLY - (Complete)	1	30-2 to 30-648 inclusive
	24948-00	YZ	* BRAKE AND ARM ASSEMBLY - (Complete)	1	30-649 and up, 39-1 and up
-33	21415-00		* LINK ASSEMBLY - Landing gear transmission brake	1	30-2 to 30-648 inclusive
-34	21418-00		* ROD ASSEMBLY - Landing gear transmission brake	1	
-35	81262-82		* LINK - Landing gear transmission brake rod	1	

A - Used if Dura Transmission is installed. Identified by Part No. 1010250 stamped on Transmission housing.  
 B - Also Order Brake and Arm Assembly 24948-00 if existing assembly does not include a plunger type brake.  
 Y - Used on PA-30 airplanes only.  
 Z - Used on PA-39 airplanes only.

When ordering, always specify Part Number, Description and Serial Number of Aircraft



Figure and Index Number	Part Number	Code	NOMENCLATURE	No. Req.	SERIAL NUMBERS AFFECTED
29-36	455 180		CONDUIT	2	
-37	21109-03		ROD ASSEMBLY - Nose gear push-pull	1	
-38	452 412		BEARING - Rod end	2	
-39	452 377		BEARING - Rod end	4	
-40	14843-79		BUSHING - Spacer, rod end	2	
-41	85012-100		WASHER	2	
-42	83302-55	Y	SPRING - Coil	1	30-2 to 30-92 inclusive
	83302-31	YZ	SPRING - Coil	1	30-93 and up, 39-1 and up
-43	20953-00		SPACER - Retraction conduit	2	
-44	20952-00		SPACER - Retraction conduit	1	
-45	26522-00	A	SPRING - Landing gear safety	1	
-46	26542-00	A	LOCK ASSEMBLY - Landing gear safety	1	
-47	29999-02	A	BUSHING - Landing gear safety	1	
-48	407 564	A	WASHER - (AN960-10)	9	
-49	26529-00	A	BOLT - Landing gear safety	1	
-50	400 466		BOLT - (AN3-43A)	2	
	407 564		WASHER - (AN960-10)	3	
	407 584		WASHER - (AN960-10L)	1	
	404 835		NUT - (MS20364-1032C)	2	

A - Used on PA-30 with serial numbers 30-1717, 30-1745 and up, and PA-39 with serial numbers 39-1 and up. Also used on PA-30 with serial numbers 30-2 to 30-1716, 30-1718 to 30-1744 inclusive if Landing Gear Emergency Extension Security Installation Kit 760 627 has been installed per Service Spares Letter SP-325.

Y - Used on PA-30 airplanes only.  
Z - Used on PA-39 airplanes only.

When ordering, always specify Part Number, Description and Serial Number of Aircraft

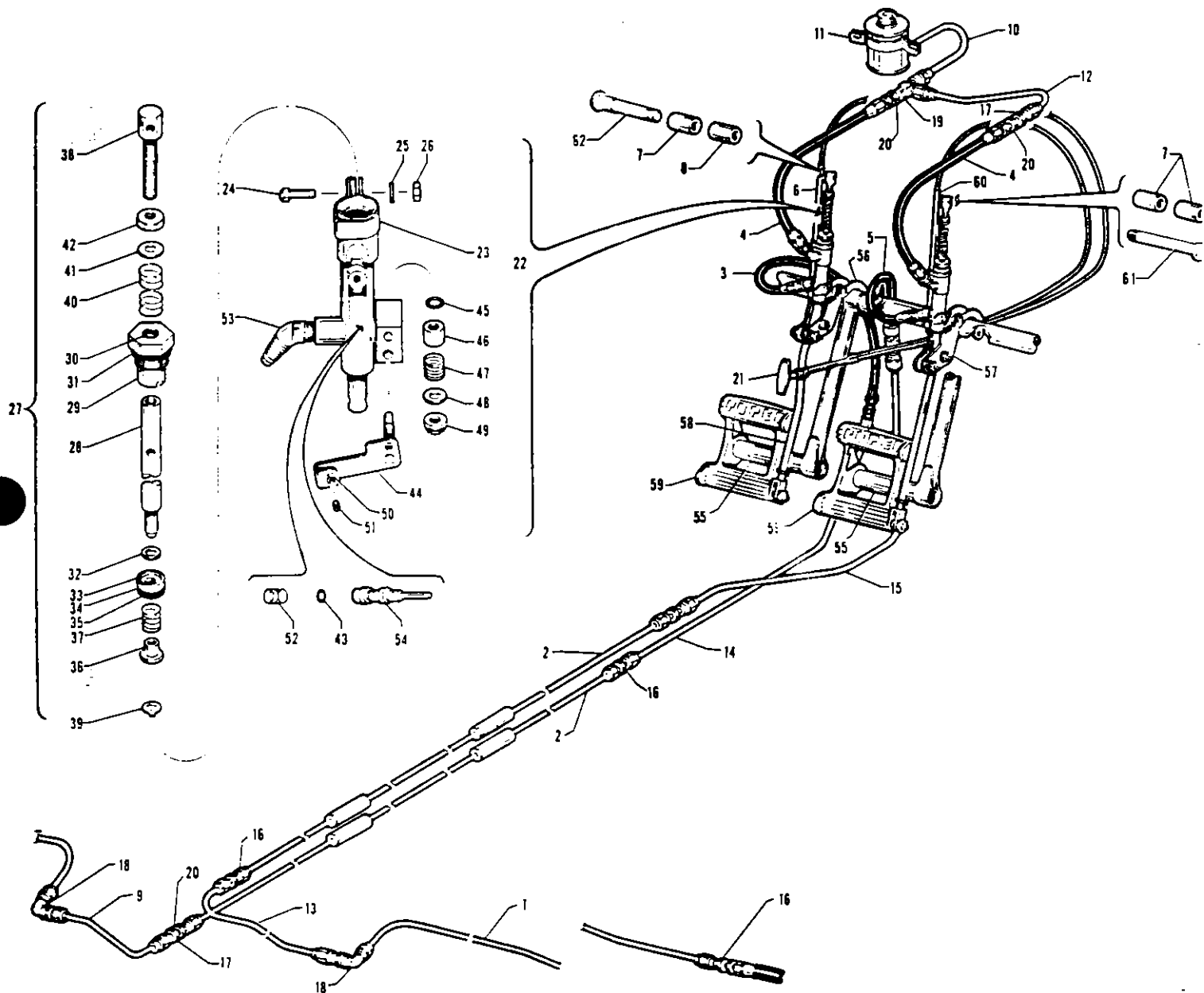

Figure 30. Toe Brake Installation



Figure and Index Number	Port Number	Code	NOMENCLATURE	No. Req.	SERIAL NUMBERS AFFECTED
30-	23853		DRAWING - Toe Brake Installation		
-1	21098-00		LINE ASSEMBLY - Brake	2	
-2	22323-00		LINE ASSEMBLY - Brake	2	
-3	17766-03	A	HOSE - Flexible (3/16" I.D. x 10-1/4" L)	1	
	17766-92	Z	HOSE - Flexible (3/16" I.D. x 12-1/2" L)	1	39-84 and up
-4	17766-44	A	HOSE - Flexible (1/4" I.D. x 11-3/4" L)	2	
	17766-77	Z	HOSE - Flexible (1/4" I.D. x 12-1/4" L)	2	39-84 and up
-5	17766-03	A	HOSE - Flexible (3/16" I.D. x 10-1/4" L)	1	
	17766-04	Z	HOSE - Flexible (3/16" I.D. x 11-3/4" L)	1	39-84 and up
-6	13586-85		TUBE - Plastic	1	
-7	14976-64		BUSHING - Brake cylinder attachment	3	
-8	14976-65		BUSHING - Brake cylinder attachment	1	30-2 and up, 39-1 to 39-119
	80022-119	Z	BUSHING - Brake cylinder attachment	1	39-120 and up
-9	21017-00		LINE ASSEMBLY - Brake	1	
-10	24221-00		LINK ASSEMBLY - Brake	1	
-11	22270-03		RESERVOIR ASSEMBLY - Brake fluid	1	
-12	22288-00		LINE ASSEMBLY - Brake	1	
-13	22313-00		LINE ASSEMBLY - Brake	1	
-14	22320-00		LINE ASSEMBLY - Brake	1	
-15	22321-00		LINE ASSEMBLY - Brake	1	
-16	491 050		UNION - (AN815-4D)	7	
-17	491 060		UNION - (AN832-4D)	2	
-18	458 900		ELBOW - 90° (AN833-4D)	2	
-19	488 383		TEE - (AN834-4D)	1	
-20	477 618		NUT - (AN924-4D)	5	
-21	455 256		CONTROL - Brake	1	
-22	455 929		CYLINDER ASSEMBLY - Master (10-5)	2	
-23	751 573		HYDRAULIC CYLINDER ASSEMBLY - (189-1)	1	
-24	756 116		SCREW - F. H. Cap (8-32 x 1/2)	1	
-25	753 171		WASHER - Lock (1208)	1	
-26	752 491		NUT - Jam (8 x 32)	1	
-27	752 847		PISTON ROD ASSEMBLY - (182-3)	1	
-28	752 848		ROD - Piston (142-5)	1	
-29	753 519		GLAND - Packing (141-5)	1	
-30	484 701		PACKING - "O" Ring (AN6227-7)	1	
-31	484 706		PACKING - "O" Ring (AN6227-11)	1	
-32	756 618		WASHER - Nylon (95-11)	1	
-33	753 857		PISTON ASSEMBLY - (92-15)	1	
-34	755 858		PISTON - (148-9)	1	
-35	752 746		PACKING - "O" Ring (AN6227-6)	1	
-36	753 381		BUSHING - (145-15)	1	
-37	756 117		SPRING - (82-8)	1	
-38	753 827		CLEVIS - (143-4)	1	
-39	752 855		RING - Snap (155-5)	1	
-40	756 118		SPRING - (82-9)	1	
-41	407 585		WASHER - (AN960-416L)	1	
-42	752 490		NUT - Jam (1/4 x 28)	1	
-43	752 791		PACKING - "O" Ring (AN6227-1)	1	

A - Used on PA-30 with serial numbers 30-2 and up. and PA-39 with serial numbers 39-1 to 39-83 inclusive.  
Z - Used on PA-39 airplanes only.

When ordering, always specify Part Number, Description and Serial Number of Aircraft



TOE BRAKE INSTALLATION



SECTION III  
Chassis Group

Figure and Index Number	Part Number	Code	NOMENCLATURE	No. Req	SERIAL NUMBERS AFFECTED
30-44	753 828		CAM ASSEMBLY - (161-2)	1	
-45	484 700		PACKING - "O" Ring (AN6227-5)	2	
-46	751 445		BUSHING - (145-7)	1	
-47	756 119		SPRING - (82-10)	1	
-48	407 564		WASHER - (AN960-10)	1	
-49	404 835		NUT - (AN364-1032)	1	
-50	751 446		BUSHING - (145-9)	1	
-51	756 120		SCREW - Set (8-32 x 1/8)	1	
-52	756 121		SPRING - (82-11)	1	
-53	458 891		FITTING - Tube (AN823-4D)	2	
-54	753 110		VALVE - (146-2)	1	
-55	22226-00		TUBE	2	
-56	22201-00		LINK - Toe brake idler	2	
-57	22201-01		LINK - Toe brake idler	2	
-58	22249-00	Y	ROD ASSEMBLY - Connecting, right	1	30-2 to 30-558 inclusive
	22249-03	YZ	ROD ASSEMBLY - Connecting, right	1	30-559 and up, 39-1 and up
	22250-00	Y	ROD ASSEMBLY - Connecting, left	1	30-2 to 30-558 inclusive
	22250-03	YZ	ROD ASSEMBLY - Connecting, left	1	30-559 and up, 39-1 and up
-59	22048-00		PEDAL - Brake and rudder	2	
-60	13586-32		TUBE - Plastic	1	
-61	400 693		BOLT - (AN23-31)	1	
-62	400 692		BOLT - (AN23-30)	1	30-2 and up, 39-1 to 39-119
	27229-00	Z	BOLT - Special	1	39-120 and up

Y - Used on PA-30 airplanes only.  
Z - Used on PA-39 airplanes only.

When ordering, always specify Part Number, Description and Serial Number of Aircraft

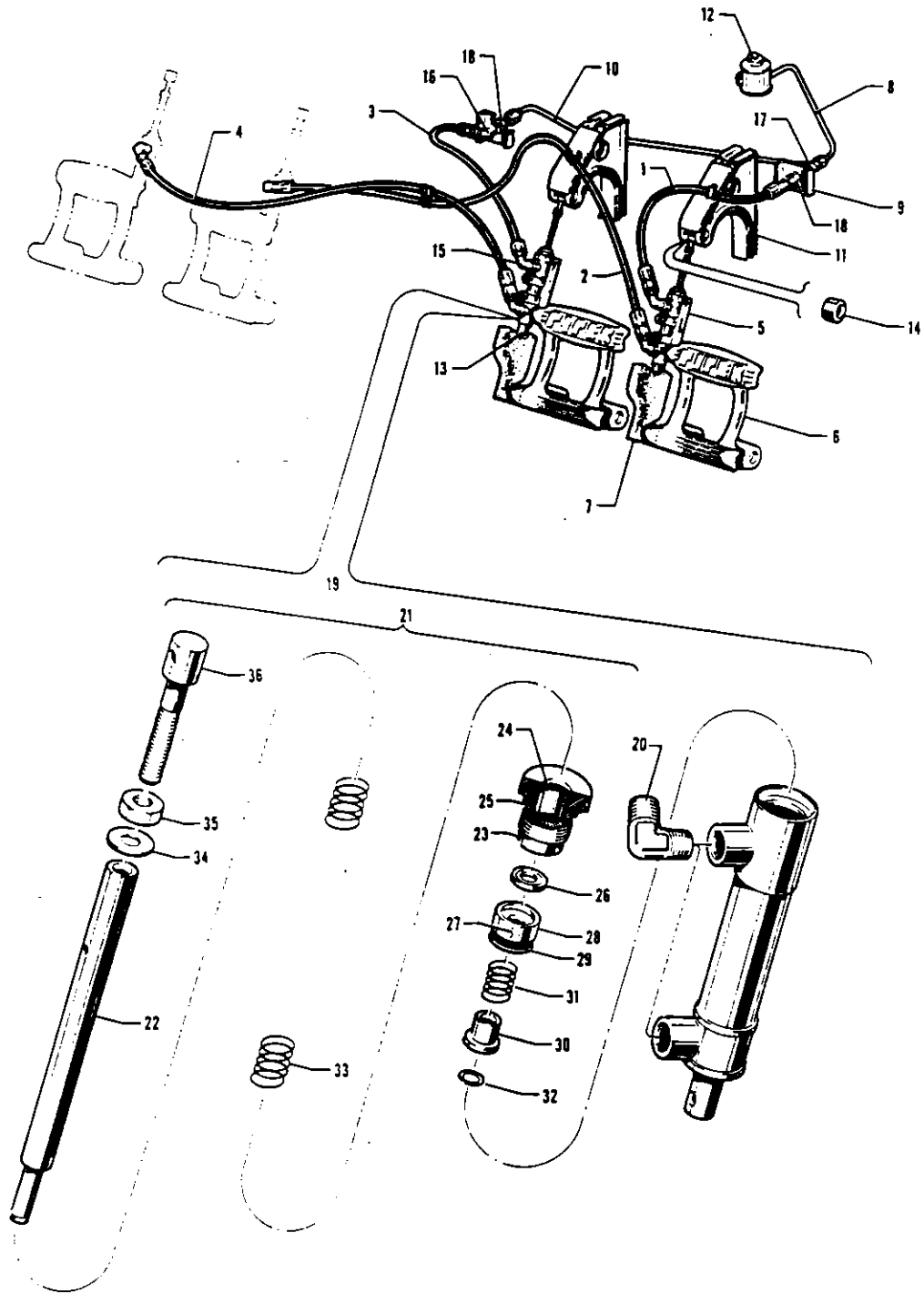

Figure 30A. Dual Brake Installation



Figure and Index Number	Part Number	Code	NOMENCLATURE	No. Req.	SERIAL NUMBERS AFFECTED
30A-	24438		DRAWING - Dual Brake Installation		
-1	17766-77	A	HOSE ASSEMBLY - Flexible, 12-1/4" L	1	
	39999-13	Z	HOSE ASSEMBLY - Flexible, 15" L	1	39-84 and up
-2	17766-78	A	HOSE ASSEMBLY - Flexible, 26-11/16" L	1	
	17766-80	Z	HOSE ASSEMBLY - Flexible, 29-3/4" L	1	39-84 and up
-3	17766-79	A	HOSE ASSEMBLY - Flexible, 10-5/8" L	1	
	17766-77	Z	HOSE ASSEMBLY - Flexible, 12-1/4" L	1	39-84 and up
-4	17766-80		HOSE ASSEMBLY - Flexible, 29-3/4" L	1	
-5	24385-00		BRACKET ASSEMBLY - Brake cylinder cover	2	
-6	24392-00		PEDAL - Brake and rudder	2	
-7	24393-00		COVER - Brake cylinder	2	
-8	24394-00		LINE ASSEMBLY - Brake cylinder reservoir outlet	1	
-9	24426-00		PLATE - Fuselage bulkhead reinforcement	2	
-10	24427-00		LINE ASSEMBLY - Brake	1	
-11	24408-00	A	BRACKET ASSEMBLY - Brake cylinder, left	1	
	27113-02	Z	BRACKET ASSEMBLY - Brake cylinder, left	1	39-84 and up
	24409-00	A	BRACKET ASSEMBLY - Brake cylinder, right	1	
	27113-03	Z	BRACKET ASSEMBLY - Brake cylinder, right	1	39-84 and up
-12	22270-00		RESERVOIR ASSEMBLY - Brake fluid	1	
-13	24428-00	A	TUBE - Brake cylinder extension	2	
	24428-02	Z	TUBE - Brake cylinder extension	2	39-84 and up
-14	61402-71		BUSHING	1	
-15	458 894		ELBOW - (AN822-4D)	4	
-16	458 910		ELBOW - (AN837-4D)	1	
-17	488 311		TEE - (AN804-4D)	1	
-18	477 618		NUT - (AN924-4D)	1	
-19	455 931		CYLINDER ASSEMBLY - Master (10-19)	2	
-20	458 894		ELBOW - (AN822-4D)	2	
-21	752 847		PISTON ROD ASSEMBLY - (182-3)	1	
-22	752 848		ROD - Piston (142-5)	1	
-23	755 810		GLAND - Packing (141-5)	1	
-24	484 701		PACKING - "O" Ring (AN6227-7)	1	
-25	484 706		PACKING - "O" Ring (AN6227-11)	1	
-26	756 618		WASHER - Nylon (95-11)	1	
-27	755 857		PISTON ASSEMBLY - (92-15)	1	
-28	755 858		PISTON - (148-9)	1	
-29	752 746		PACKING - "O" Ring (AN6227-8)	1	
-30	753 381		BUSHING - (145-15)	1	
-31	756 117		SPRING - (82-8)	1	
-32	752 855		RING - Snap (155-5)	1	
-33	756 118		SPRING - (82-9)	1	
-34	407 585		WASHER - (AN960-416L)	1	
-35	752 490		NUT - Jam (1/4 x 28)	1	
-36	753 827		CLEVIS - (143-4)	1	

A - Used on PA-30 with serial numbers 30-2 and up, and PA-39 with serial numbers 39-1 to 39-83 inclusive.  
Z - Used on PA-39 airplanes only.

When ordering, always specify Part Number, Description and Serial Number of Aircraft

**1 1 1 2**

**INTENTIONALLY LEFT BLANK**

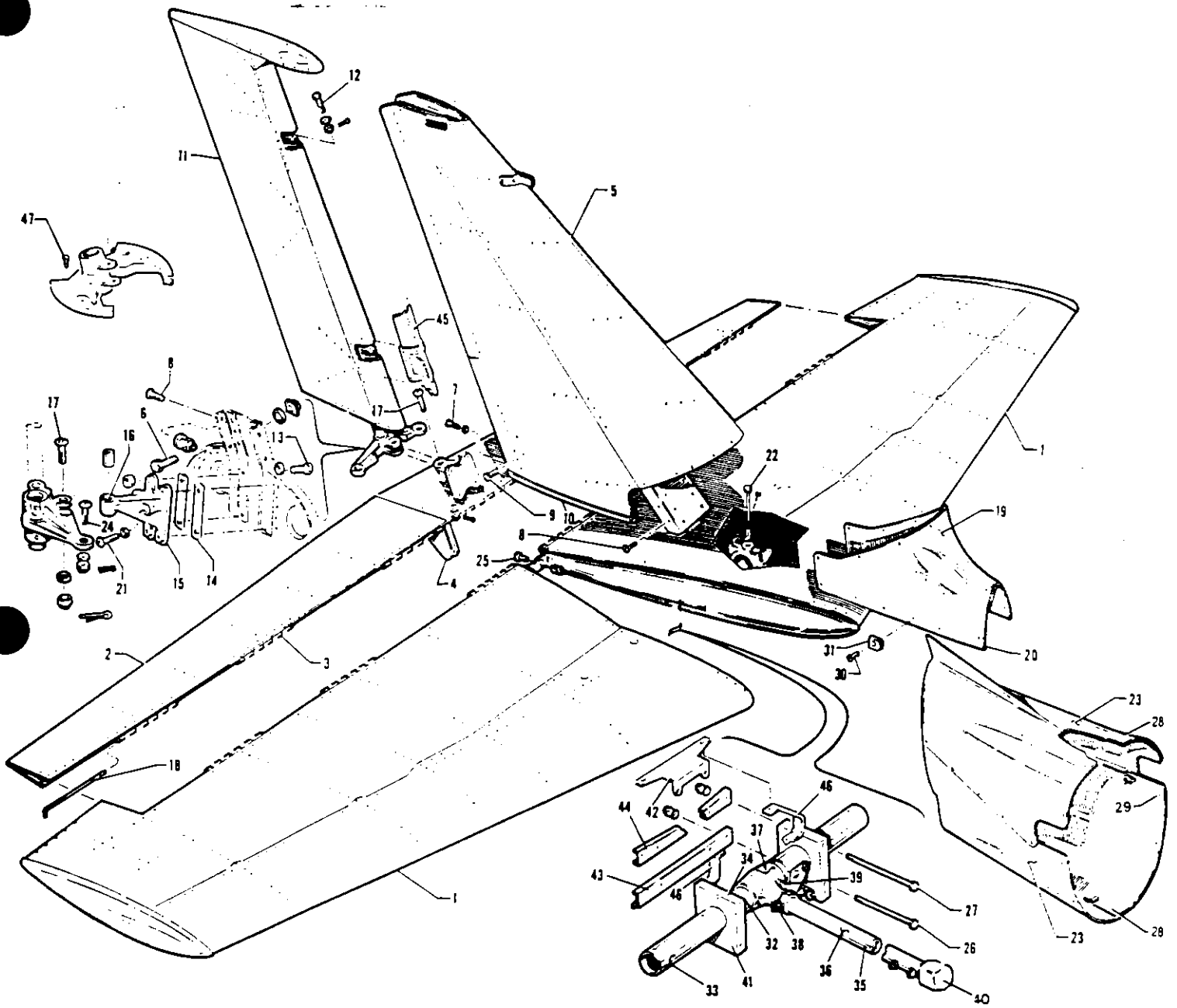

Figure 31. Tail Surfaces Installation

REVISED: FEBRUARY 1977

1113

PA-30  
PA-39



Figure and Index Number	Part Number	Code	NOMENCLATURE	No. Req.	SERIAL NUMBERS AFFECTED
31-	23588	D	DRAWING - Tail Surfaces Installation		
	26352	E	DRAWING - Tail Surfaces Installation		
-1	22523-00	AD	STABILATOR ASSEMBLY - Left	1	
	25100-00	AE	STABILATOR ASSEMBLY - Left	1	
	22523-01	AD	STABILATOR ASSEMBLY - Right	1	
	25100-01	AE	STABILATOR ASSEMBLY - Right	1	
-2	22518-00	D	TAB ASSEMBLY - Stabilator, left	1	
	25098-00	E	TAB ASSEMBLY - Stabilator, left	1	
	22518-01	D	TAB ASSEMBLY - Stabilator, right	1	
	25098-01	E	TAB ASSEMBLY - Stabilator, right	1	
-3	16914-00		HINGE	3	
-4	20195-00	D	HORN - Stabilator tab	1	
	25097-00	E	HORN - Stabilator tab	1	
-5	23446-06	BY	FIN ASSEMBLY	1	
	23446-08	Z	FIN ASSEMBLY	1	
	23446-07	F	FIN ASSEMBLY	1	
-6	400 002		BOLT - (AN4-5A)	6	
	404 888		NUT - (MS20365-428C)	6	
	407 565		WASHER - (AN960-416)	6	
-7	401 266		BOLT - (AN3-5A)	4	
	407 564		WASHER - (AN960-10)	4	
-8	411 231		SCREW - (NAS222-12)	4	
	404 888		NUT - (MS20365-428C)	4	
	407 564		WASHER - (AN960-416)	4	
-9	411 230		SCREW - (NAS222-11)	4	
	404 888		NUT - (MS20365-428C)	4	
	407 565		WASHER - (AN960-416)	4	
-10	19795-00		MOULDING - Extruded section	32	
-11	23447-15	CG	RUDDER ASSEMBLY	1	
	23447-16	CZ	RUDDER ASSEMBLY	1	39-84 and up
-12	400 108		BOLT - (AN4-13)	2	
	407 565		WASHER - (AN960-416)	2	
	404 101		NUT - (AN310-4)	2	
	424 051		PIN - Cotter (AN390-2-2)	2	
-13	401 270		BOLT - (AN3-11A)	4	
	407 564		WASHER - (AN960-10)	4	
	404 857		NUT - (MS20365-1032C)	4	
-14	S1262-72		SHM	AR	

- A - See Figure 32 for component parts.
- B - See Figure 34 for component parts.
- C - See Figure 33 for component parts.
- D - Used on PA-30 with serial numbers 30-2 to 30-1716 inclusive. 30-1718 to 30-1744 inclusive.
- E - Used on PA-30 with serial numbers 30-1717, 30-1745 and up, and PA-39 with serial numbers 39-1 and up.
- F - Used if anti-collision red strobe light is installed.
- G - Used on PA-30 with serial numbers 30-2 and up, and PA-39 with serial numbers 39-1 to 39-83 inclusive.
- Y - Used on PA-30 airplanes only.
- Z - Used on PA-39 airplanes only.

When ordering, always specify Part Number, Description and Serial Number of Aircraft



Figure and Index Number	Part Number	Code	NOMENCLATURE	No. Req.	SERIAL NUMBERS AFFECTED
31-15	20713-00		BRACKET ASSEMBLY - Rudder lower hinge	1	
-16	452 347		BEARING - (B-47)	1	
-17	400 708		BOLT - (AN24-23)	1	
	407 565		WASHER - (AN960-416)	1	
	404 101		NUT - (AN310-4)	1	
	424 051		PIN - Cotter (AN380-2-2)	1	
-18	21510-02		PIN - Hinge	6	
-19	23445-00		FAIRING ASSEMBLY - Fin	1	
-20	19795-00		MOULDING EXTRUDED SECTION	1	
-21	419 991		SCREW - Button head ( 10-32 x 1 L)	2	
	404 224		NUT - Hex (AN315-3R)	2	
-22	502 342		BOLT - (AN175-C32A)	4	
	407 586		WASHER - (AN960-516L)	4	
	404 889		NUT - (MS20365-524C)	4	
-23	23585-02	A	FAIRING - Fuselage tail, bottom	1	
	25975-02	B	FAIRING - Fuselage tail, bottom	1	
	23585-03	A	FAIRING - Fuselage tail, top	1	
	25975-03	B	FAIRING - Fuselage tail, top	1	
-24	400 675	C	BOLT - (AN23-13)	2	
	407 569	C	WASHER - (AN960-10)	2	
	404 100	C	NUT - (AN310-3)	2	
	424 051	C	PIN - Cotter (AN380-2-2)	2	
-25	400 002		BOLT - (AN4-5A)	1	
	407 565		WASHER - (AN960-416)	1	
	404 888		NUT - (MS20365-428C)	1	
-26	401 382		BOLT - (AN5-56A)	2	
	407 566		WASHER - (AN960-516)	2	
	404 889		NUT - (MS20365-524C)	2	
-27	401 384		BOLT - (AN5-63A)	2	
	407 566		WASHER - (AN960-516)	2	
	404 889		NUT - (MS20365-524C)	2	
-28	414 748		SCREW - (AN507-632-R8)	16	
	494 071		WASHER - ( A3236-012-1)	16	
	406 362		NUT - ( C8095-632-1)	16	
-29	414 748		SCREW - (AN507-632-R8)	4	
	494 071		WASHER - ( A3236-012-1)	4	
-30	419 946		SCREW - Sheet metal screw ( 6 x 3/8, Type "B")	22	
-31	406 363		NUT - Tinnerman ( A6052-6Z-3)	8	
-32	22655-06	Y	TUBE ASSEMBLY - Stabilator torque	1	
	27183-00	Z	TUBE ASSEMBLY - Stabilator torque	1	
-33	22655-07	Y	TUBE - Stabilator torque	1	
	27183-03	Z	TUBE - Stabilator torque	1	

A - Used on PA-30 with serial numbers 30-2 to 30-1716 inclusive, 30-1718 to 30-1744 inclusive.  
 B - Used on PA-30 with serial numbers 30-1717, 30-1745 and up, and PA-39 with serial numbers 39-1 and up.  
 C - Used on PA-30 with serial numbers 30-2 and up, and PA-39 with serial numbers 39-1 to 39-83 inclusive.  
 Y - Used on PA-30 airplanes only.  
 Z - Used on PA-39 airplanes only.

When ordering, always specify Part Number, Description and Serial Number of Aircraft



Figure and Index Number	Part Number	Code	NOMENCLATURE	No. Req.	SERIAL NUMBERS AFFECTED
31-34	20204-00		COLLAR ASSEMBLY - Stabilator torque, right	1	
	20205-00		COLLAR ASSEMBLY - Stabilator torque, left	1	
-35	22882-00		HORN ASSEMBLY - Stabilator torque	1	
-36	22880-00		TUBE - Stabilator torque	1	
-37	20397-00		HORN - Stabilator torque	1	
-38	402 321		BOLT - Stabilator horn (AN174-22A)	1	
	404 888		NUT - Stabilator horn (AN365-428)	1	
-39	402 346		BOLT - Stabilator horn (AN175-33A)	2	
	404 889		NUT - Stabilator horn (MS20365-524)	2	
	407 566		WASHER - Stabilator horn (AN960-516)	2	
-40	23594-00		WEIGHT - Stabilator balance	1	
-41	20207-11		BLOCK ASSEMBLY - Stabilator torque tube bearing, left	1	
	20208-08		BLOCK ASSEMBLY - Stabilator torque tube bearing, right	1	
-42	27104-00	Z	GUARD - Control cable	1	39-84 and up
-43	24179-00		CHANNEL ASSEMBLY - Stabilator bearing block reinforcement	1	
-44	27112-00		CHANNEL ASSEMBLY - Stabilator bearing block reinforcement	1	
-45	27200-08	A	SEAL ASSEMBLY - Rudder	1	
-46	27105-00	Z	BRACKET - Cable ground mounting, left	1	39-84 and up
	27105-01	Z	BRACKET - Cable ground mounting, right	1	39-84 and up
-47	416 184	Z	SCREW - (MS35275-244)	2	39-84 and up

A - Used on PA-30 airplanes if Airflow Modification Kit 760 409 has been installed per Service Letter 558.  
Z - Used on PA-39 airplanes only.

When ordering, always specify Part Number, Description and Serial Number of Aircraft



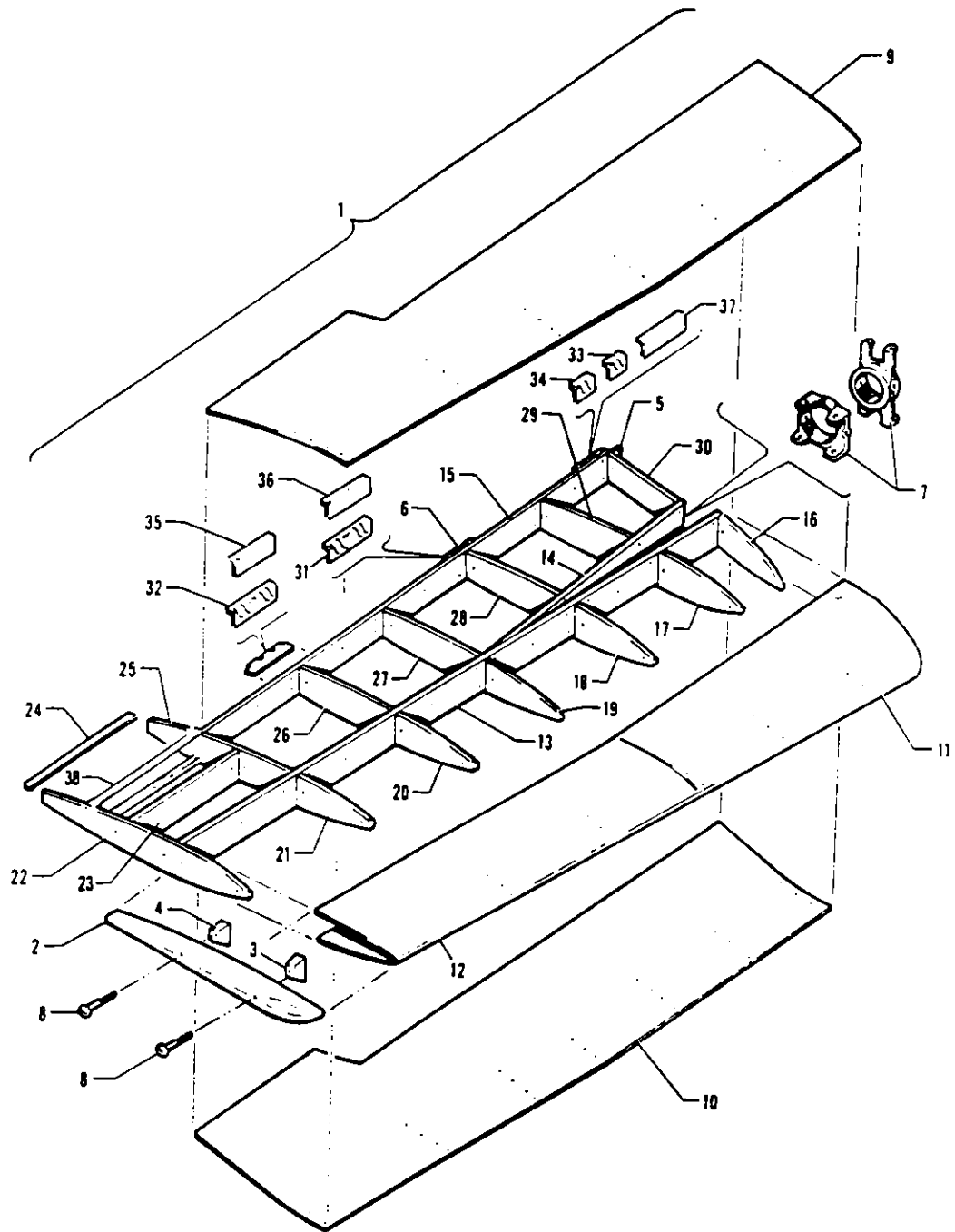

Figure 32. Stabilator Assembly



Figure and Index Number	Part Number	Code	NOMENCLATURE	No. Req	SERIAL NUMBERS AFFECTED
32-	22523	A	DRAWING - Stabilator Assembly		
	25100	B	DRAWING - Stabilator Assembly		
-1	22523-00	A	STABILATOR ASSEMBLY - LH	1	
	25100-00	B	STABILATOR ASSEMBLY - LH	1	
	22523-01	A	STABILATOR ASSEMBLY - RH	1	
	25100-01	B	STABILATOR ASSEMBLY - RH	1	
-2	21556-00	A	TIP ASSEMBLY - Stabilator	1	
	25066-00	B	TIP ASSEMBLY - Stabilator	1	
-3	20257-02		BLOCK - Stabilator tip spacer, front	1	
-4	20257-03		BLOCK - Stabilator tip spacer, rear	1	
-5	20193-25	A	FITTING - Rear attachment	1	
	25082-00	B	FITTING - Rear attachment	1	
-6	20193-28		HINGE - Stabilator trim tab	3	
-7	21420-04	A	FITTING - Stabilator attachment, inboard	1	
	25083-02	B	FITTING - Stabilator attachment, inboard	1	
	21420-05	A	FITTING - Stabilator attachment, outboard	1	
	25083-03	B	FITTING - Stabilator attachment, outboard	1	
-8	415 292		SCREW - Oval head 10 x 32 x 2 1/2 L. front	1	
	415 289		SCREW - Oval head 10 x 32 x 2 L. rear	1	
-9	22523-04	A	SKIN - Stabilator top, LH	1	
	25100-04	B	SKIN - Stabilator top, LH	1	
	22523-05	A	SKIN - Stabilator top, RH	1	
	25100-05	B	SKIN - Stabilator top, RH	1	
-10	22523-06	A	SKIN - Stabilator bottom, LH	1	
	25100-06	B	SKIN - Stabilator bottom, LH	1	
	22523-07	A	SKIN - Stabilator bottom, RH	1	
	25100-07	B	SKIN - Stabilator bottom, RH	1	
-11	22523-02	A	SKIN - Leading edge, root	1	
	25100-02	B	SKIN - Leading edge, root	1	
-12	22523-03	A	SKIN - Leading edge, tip	1	
	25100-03	B	SKIN - Leading edge, tip	1	
-13	20197-00	A	SPAR ASSEMBLY - Stabilator, main	1	
	25110-00	B	SPAR ASSEMBLY - Stabilator, main	1	
-14	20198-00	A	SPAR ASSEMBLY - Stabilator, stub	1	
	25111-00	B	SPAR ASSEMBLY - Stabilator, stub	1	
-15	22523-08	A	SPAR ASSEMBLY - Stabilator, rear, LH	1	
	25105-00	B	SPAR ASSEMBLY - Stabilator, rear, LH	1	
	22523-09	A	SPAR ASSEMBLY - Stabilator, rear, RH	1	
	25105-01	B	SPAR ASSEMBLY - Stabilator, rear, RH	1	
-16	20193-07	A	RIB - Stabilator nose	1	
	25094-00	B	RIB - Stabilator nose	1	
-17	20193-08	A	RIB - Stabilator nose	1	
	25067-05	B	RIB - Stabilator nose	1	
-18	20193-09	A	RIB - Stabilator nose	1	
	25067-04	B	RIB - Stabilator nose	1	
-19	20193-10	A	RIB - Stabilator nose	1	
	25067-03	B	RIB - Stabilator nose	1	

A - Used on PA-30 with serial numbers 30-2 to 30-1716 inclusive, 30-1718 to 30-1744 inclusive.

B - Used on PA-30 with serial numbers 30-1717, 30-1745 and up, and PA-39 with serial numbers 39-1 and up.

When ordering, always specify Part Number, Description and Serial Number of Aircraft

STABILATOR ASSEMBLY



SECTION IV  
Tail Surfaces Group

Figure and Index Number	Part Number	Code	NOMENCLATURE	No. Req.	SERIAL NUMBERS AFFECTED
32-20	20193-11	A	RIB - Stabilator nose	1	
	25067-02	B	RIB - Stabilator nose	1	
-21	20193-12	A	RIB - Stabilator nose	1	
	25065-02	B	RIB - Stabilator nose	1	
-22	20193-29	A	RIB ASSEMBLY - Stabilator, tip	1	
	25060-00	B	RIB ASSEMBLY - Stabilator, tip	1	
-23	20193-41	A	RIB - Stiffener	1	
	25099-00	B	RIB - Stiffener	1	
-24	20193-24		STRIP - Stiffener	1	
-25	20193-19	A	RIB - Stabilator, rear	1	
	25065-03	B	RIB - Stabilator, rear	1	
-26	20193-18	A	RIB - Stabilator, rear	1	
	25077-05	B	RIB - Stabilator, rear	1	
-27	20193-17	A	RIB - Stabilator, rear	1	
	25077-04	B	RIB - Stabilator, rear	1	
-28	20193-16	A	RIB - Stabilator, rear	1	
	25077-03	B	RIB - Stabilator, rear	1	
-29	20193-15	A	RIB - Stabilator, rear	1	
	25077-02	B	RIB - Stabilator, rear	1	
-30	20193-14	A	RIB - Stabilator, rear	1	
	25078-00	B	RIB - Stabilator, rear	1	
-31	24193-00	A	PLATE - Stabilator reinforcement	1	
	25103-02	B	PLATE - Stabilator reinforcement	1	
-32	24193-02	A	PLATE - Stabilator reinforcement	1	
	25103-03	B	PLATE - Stabilator reinforcement	1	
-33	24191-00	A	PLATE - Stabilator reinforcement	1	
	25101-00	B	PLATE - Stabilator reinforcement	1	
-34	24192-00	A	PLATE - Stabilator reinforcement	1	
	25102-00	B	PLATE - Stabilator reinforcement	1	
-35	20193-04	A	HINGE - Doubler	1	
	25107-03	B	HINGE - Doubler	1	
-36	20193-05	A	HINGE - Doubler	1	
	25107-02	B	HINGE - Doubler	1	
-37	20193-06	A	HINGE - Doubler, LH	1	
	25106-00	B	HINGE - Doubler, LH	1	
	20193-31	A	HINGE - Doubler, RH	1	
	25106-01	B	HINGE - Doubler, RH	1	
-38	27059-00	A	CHANNEL - Stabilator skin stiffener	4	

A - Used on PA-30 with serial numbers 30-2 to 30-1716 inclusive. 30-1718 to 30-1744 inclusive.  
 B - Used on PA-30 with serial numbers 30-1717, 30-1745 and up. and PA-39 with serial numbers 39-1 and up.

When ordering, always specify Part Number, Description and Serial Number of Aircraft

**1 120**  
**INTENTIONALLY LEFT BLANK**

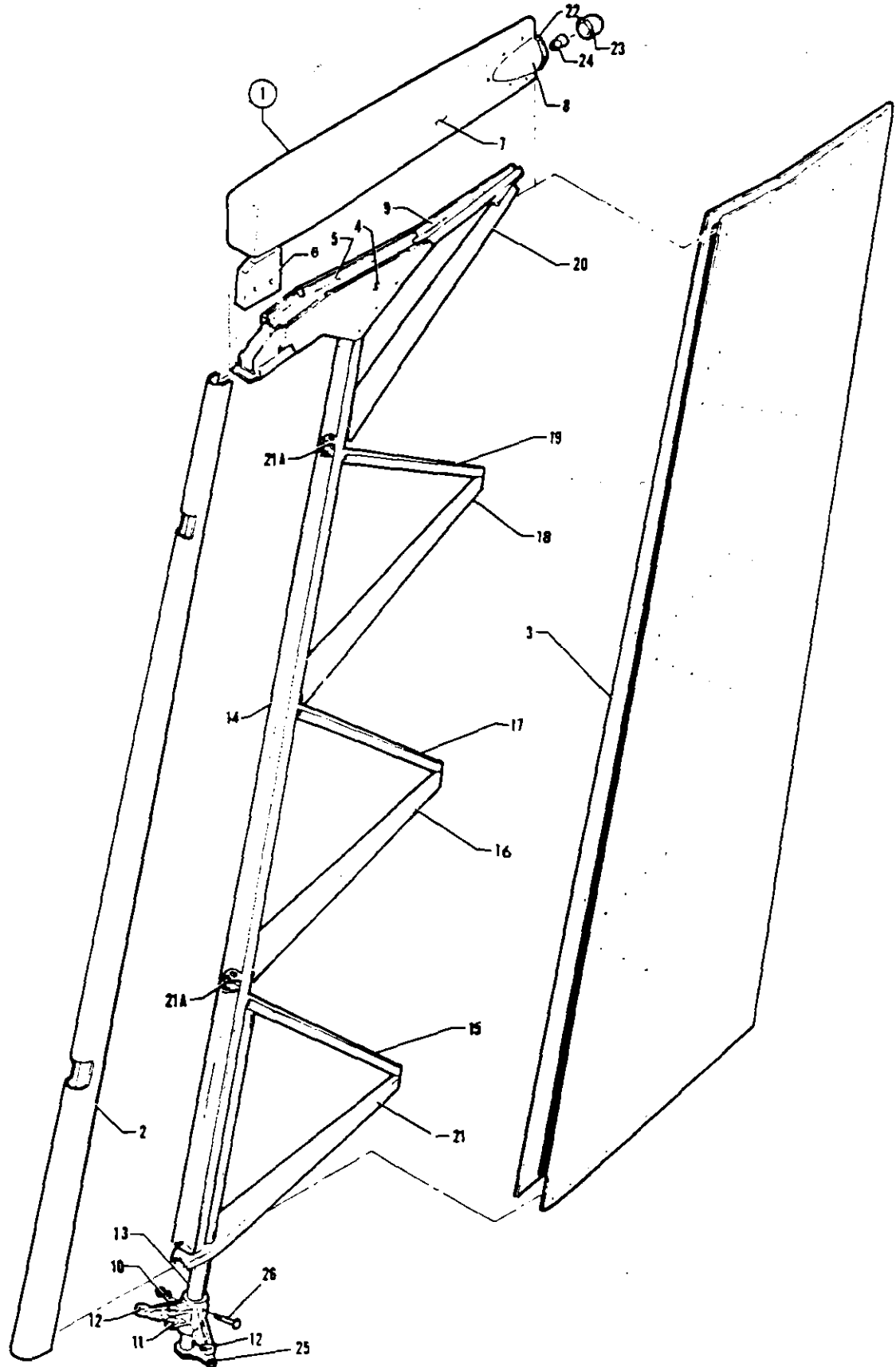

Figure 33. Rudder Assembly

PIPER PARTS CATALOG

Figure and Index Number	Part Number	Code	NOMENCLATURE	No. Req.	SERIAL NUMBERS AFFECTED
33-	23447		DRAWING - Rudder Assembly		
-1	23447-15	YZ	RUDDER ASSEMBLY	1	30-2 and up, 39-1 to 39-83
	23447-16	Z	RUDDER ASSEMBLY	1	39-84 and up
-2	23447-09		* SKIN - Leading edge	1	
-3	23447-10		* SKIN - Trailing edge	1	
-4	23437-00		* SKIN - Rudder balance arm, LH	1	
	23437-01		* SKIN - Rudder balance arm, RH	1	
-5	23436-00		* RIB - Rudder balance arm top	1	
-6	23593-00		* WEIGHT - Rudder balance	1	
-7	23595-00		* TIP ASSEMBLY - Rudder	1	
-8	16089-05		* * FAIRING ASSEMBLY - Tail light	1	
-9	23596-00		* RIB - Rudder tip	1	
-10	20185-04	Y	* HORN ASSEMBLY - Rudder	1	30-2 to 30-1090 inclusive
	25139-03	YZ	* HORN ASSEMBLY - Rudder	1	30-1091 and up, 39-1 to 39-83
	27102-00	Z	* SECTOR ASSEMBLY - Rudder	1	39-84 and up
-11	82732-99		* * BEARING	2	
-12	82732-98	YZ	* * BEARING - Rudder horn	2	30-2 and up, 39-1 to 39-83
-13	23448-00		* TUBE ASSEMBLY - Rudder torque	1	
-14	23447-02		* SPAR ASSEMBLY - Rudder	1	
-15	23447-03		* * RIB	1	
-16	23447-04		* * RIB	1	
-17	23447-05		* * RIB	1	
-18	23447-06		* * RIB	1	
-19	23447-07		* * RIB	1	
-20	23447-08		* * RIB	1	
-21	20729-04		* * RIB	1	
-21a	20183-03		* * HINGE ASSEMBLY - Rudder, bottom	1	
	20183-05		* * HINGE ASSEMBLY - Rudder, top	1	
-22	472 736		* LIGHT - White (#A2064-1073)	1	
-23	751 203		* * LENS - White	1	
-24	753 431		* * BULB - (#1073)	1	
-25	24334-00	Y	* BRACKET ASSEMBLY - Rudder trim	1	30-2 to 30-1090 inclusive
-26	402 316		BOLT - (AN174-15A)	2	
	404 888		NUT - (MS20365-428C)	2	
	407 565		WASHER - (AN960-416)	2	

Y - Used on PA-30 airplanes only.  
Z - Used on PA-39 airplanes only.

When ordering, always specify Part Number, Description and Serial Number of Aircraft

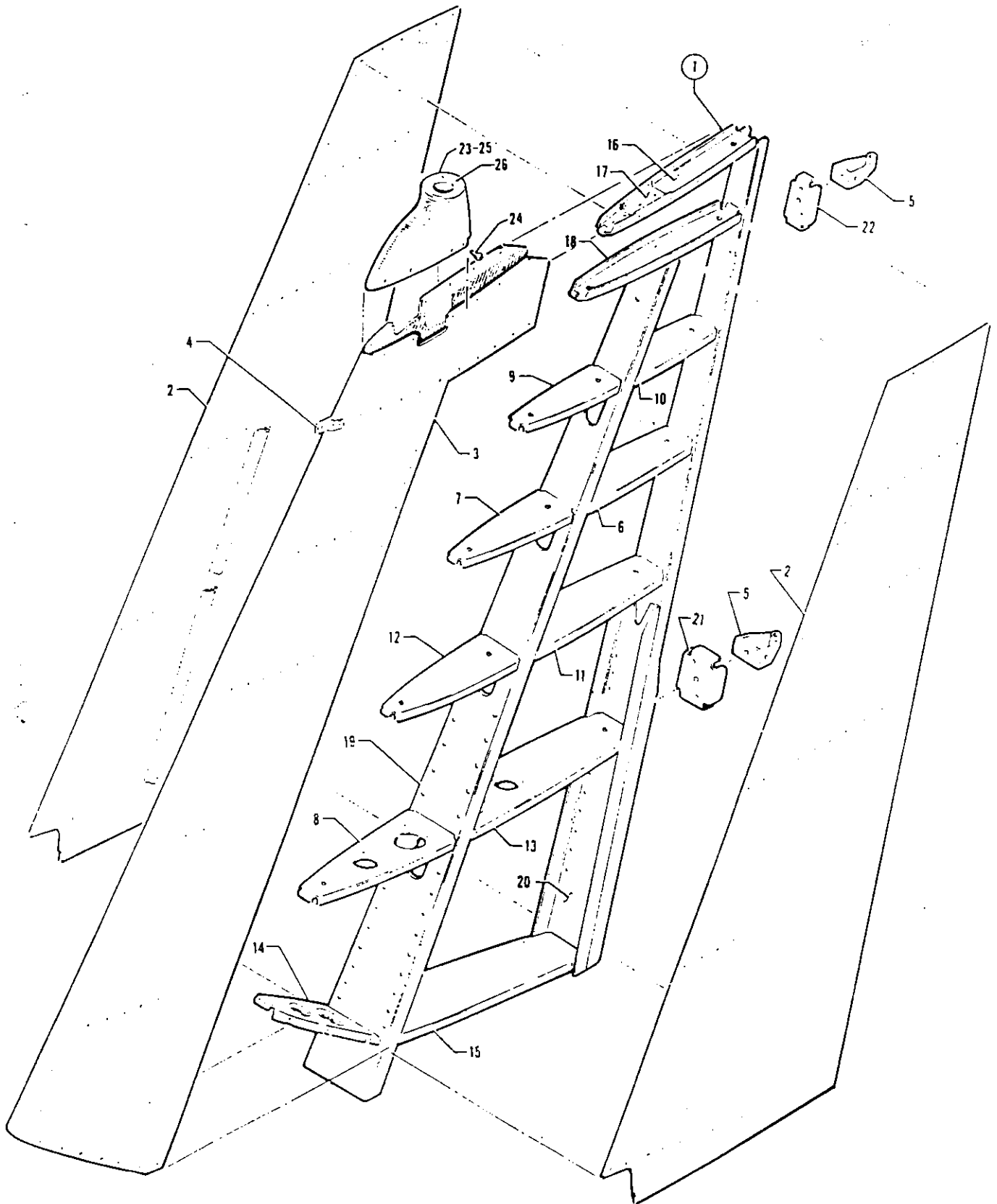

Figure 34. Fin Assembly



Figure and Index Number	Part Number	Code	NOMENCLATURE	No. Req	SERIAL NUMBERS AFFECTED
34-	23446		DRAWING - Fin Assembly		
1	23446-06	Y	FIN ASSEMBLY	1	
	23446-08	Z	FIN ASSEMBLY	1	
	23446-07	A	FIN ASSEMBLY	1	
-2	23446-04		SKIN ASSEMBLY - Fin, left	1	
	23446-05		SKIN ASSEMBLY - Fin, right	1	
-3	23446-03		SKIN - Fin, leading edge	1	
-4	20379-00		FITTING - Antenna attachment, LH	1	
	20379-01		FITTING - Antenna attachment, RH	1	
-5	20707-06		BRACKET ASSEMBLY - Rudder hinge, top	1	
	20707-07		BRACKET ASSEMBLY - Rudder hinge, bottom	1	
6	23414-00		RIB - Fin, rear	1	
-7	23415-00		RIB - Fin, nose	1	
-8	23416-00		RIB - Fin, nose	1	
-9	23417-00		RIB - Fin, nose	1	
-10	23418-00		RIB - Fin, rear	1	
-11	23419-00		RIB - Fin, rear	1	
-12	23420-00		RIB - Fin, nose	1	
-13	23427-00		RIB - Fin, rear	1	
-14	23428-00		RIB - Fin, butt nose	1	
-15	23438-00		RIB - Fin, butt rear	1	
-16	23440-00		RIB ASSEMBLY - Fin tip	1	
-17	23449-00		PLATE - Antenna attachment	1	
-18	23444-00		RIB - Fin, nose	1	
-19	23435-02		SPAR ASSEMBLY - Fin, front	1	
-20	23435-03		SPAR ASSEMBLY - Fin, rear	1	
-21	23431-00		BRACKET - Rudder hinge, lower	1	
-22	23433-00		BRACKET - Rudder hinge, upper	1	
-23	23598-00		FAIRING ASSEMBLY - Fin tip	1	
-24	415 149		SCREW - (AN526-632R8)	2	
	407 562		WASHER - (AN960-6)	2	
	404 829		NUT - (MS20364-632C)	2	
-25	27027-00	A	TIP ASSEMBLY - Fin	1	
-26	581 623	A	PLATE - Adapter mounting, "Type B"	1	

A - Used if anti-collision red strobe light is installed.  
 Y - Used on PA-30 airplanes only.  
 Z - Used on PA-39 airplanes only.

When ordering, always specify Part Number, Description and Serial Number of Aircraft



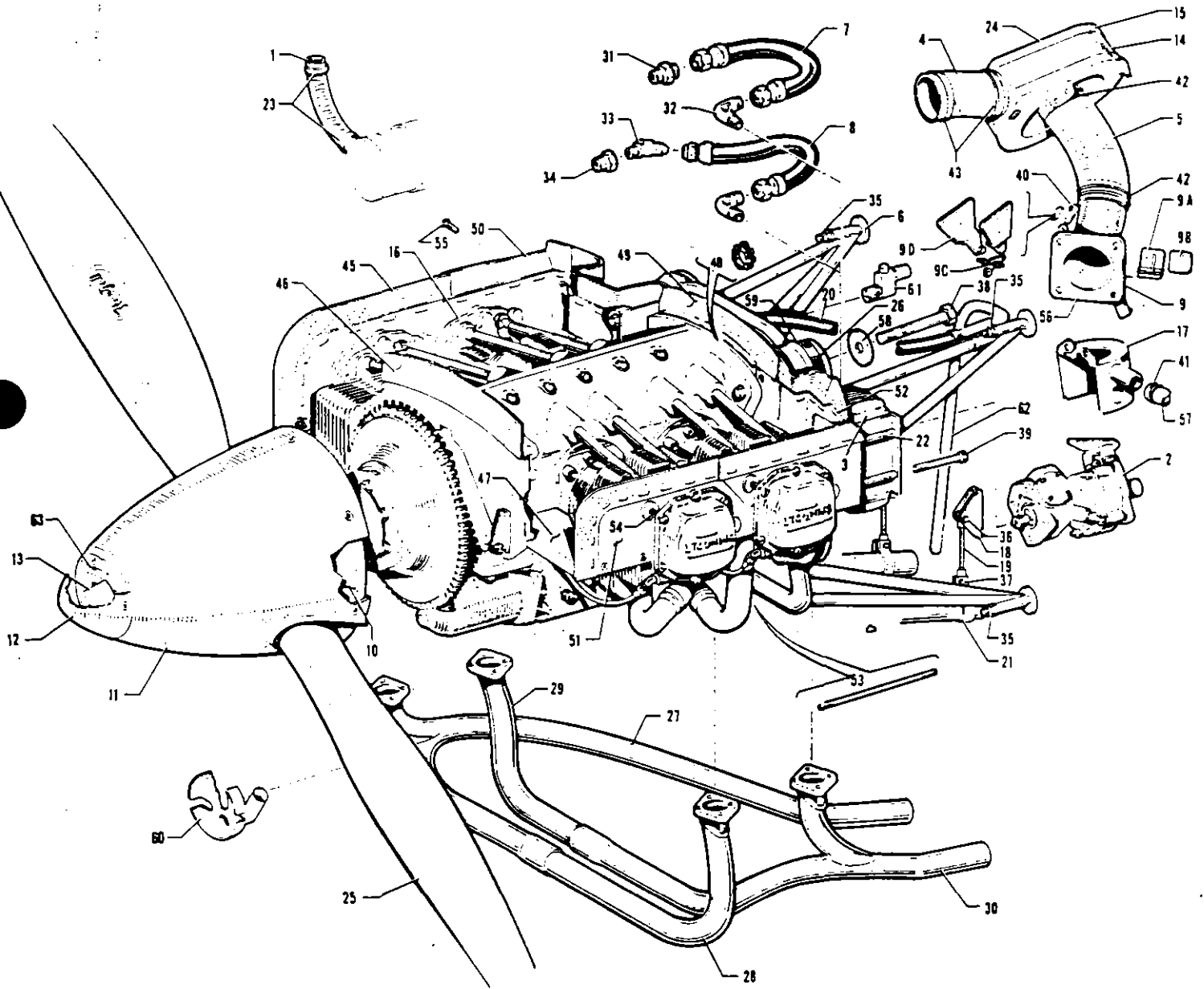

Figure 35. Power Plant and Baffle Installation



Figure and Index Number	Part Number	Code	NOMENCLATURE	No. Req.	SERIAL NUMBERS AFFECTED
35-	24060 26700 23984	F E	DRAWING - Power Plant DRAWING - Power Plant DRAWING - Baffle Installation		
-1	10525-51 10525-51 49997-12	F AF E	HOSE - Generator air, left engine HOSE - Generator air, right engine HOSE - Alternator air, left engine	1 1 1	
-2	16564-06 16564-07 16564-07 16564-08	Y Y Z G J Z	GOVERNOR ASSEMBLY - (F-6-3) GOVERNOR ASSEMBLY - (F-6-3S) GOVERNOR ASSEMBLY - Left (F-6-3S) GOVERNOR ASSEMBLY - Right (F-6-3AL)	2 2 1 1	30-2 to 30-1281 inclusive 30-1282 and up
-3	18622-00 24577-00	H H	COOLER ASSEMBLY - Oil COOLER ASSEMBLY - Oil	2 2	
-4	22502-32	D	HOSE - Air duct (7-1/2" L)	2	
-5	22502-33	D	HOSE - Air duct (9-1/2" L)	2	
-6	23561-00 23561-31	H H	MOUNT ASSEMBLY - Engine MOUNT ASSEMBLY - Engine	2 2	
-7	23745-05		HOSE ASSEMBLY - Oil cooler, upper	2	
-8	23745-06		HOSE ASSEMBLY - Oil cooler, lower	2	
-9	23810-00	D	TAKE-OFF ASSEMBLY - Alternate air	2	
-9a	23809-10	D	DOOR ASSEMBLY - Alternate air	1	
-9b	23809-04	D	SEAL - Alternate air door	1	
-9c	23995-00	D	BELLCRANK ASSEMBLY - Alternate air door	1	
-9d	25246-00	D	BRACKET ASSEMBLY - Alternate air door bellcrank	2	
-10	23815-00		BULKHEAD ASSEMBLY - Spinner, rear	2	
-11	23818-00 27068-00	Y Z	SPINNER ASSEMBLY - Propeller SPINNER ASSEMBLY - Propeller	2 2	
-12	23819-00 23819-03	B C	CAP - Propeller spinner CAP - Propeller spinner	2 2	
-13	46348-03 46348-04	B C	DECAL - Propeller pressure temperature DECAL - Propeller pressure temperature	1 1	

A - Used when dual generator is installed.  
 B - Used with HC-E2YL-2/7663-4 and HC-E2YL-2BL/J7663-4 propellers only.  
 C - Used with HC-E2YL-2BS/7663-4 and HC-E2YL-2BLS/J7663-4 propellers only.  
 D - Not used when Turbocharger is installed. Refer to Rajay Corporation Parts Catalog.  
 E - Used on PA-30 with serial numbers 30-1717, 30-1745 and up, and PA-39 with serial numbers 39-1 and up.  
 F - Used on PA-30 with serial numbers 30-2 to 30-1716 inclusive, 30-1718 to 30-1744 inclusive.  
 G - Used on PA-30 with counter-rotating right engine.  
 H - Used on Turbocharged Aircraft.  
 J - Refer to Figure 35B if Propeller Synchrophaser System is installed.  
 Y - Used on PA-30 airplanes only.  
 Z - Used on PA-39 airplanes only.

When ordering, always specify Part Number, Description and Serial Number of Aircraft



Figure and Index Number	Part Number	Code	NOMENCLATURE	No. Req.	SERIAL NUMBERS AFFECTED
35-14	23883-00	AB	BOX ASSEMBLY - Air filter	2	
	23883-05	AC	BOX ASSEMBLY - Air filter	2	
-15	23886-00	AB	COVER ASSEMBLY - Air filter	2	
	25956-00	AC	COVER ASSEMBLY - Air filter	2	
-16		AY	ENGINE ASSEMBLY - Lycoming (IO-320-B1A)	2	
		AZ	ENGINE ASSEMBLY - Lycoming, left (IO-320-B1A)	1	
		AEZ	ENGINE ASSEMBLY - Lycoming, right (LIO-320-B1A)	1	
-17	23986-00	AGY	BAFFLE ASSEMBLY - Fuel pump	2	30-2 to 30-197 inclusive
	23986-04	AHYZ	BAFFLE ASSEMBLY - Fuel pump	2	30-198 and up, 39-1 and up
-18	24039-00	A	BRACKET ASSEMBLY - Exhaust stack hanger, left	2	
	24039-00	F	BRACKET ASSEMBLY - Exhaust stack hanger, right	2	
-19	760 335	DY	KIT - Exhaust stack support (one engine)	2	30-2 to 30-1995 inclusive
	25973-00	YZ	HOSE ASSEMBLY - Exhaust stack support	4	30-1996 and up, 39-1 and up
-20	61541-23		HOSE - Oil breather	2	
-21	80002-76		CLAMP - Exhaust stack hanger, left	2	
	80002-76	F	CLAMP - Exhaust stack hanger, right	2	
-22	86062-94		TUBE - Spacer	2	
-23	454 981	B	CLAMP - (H. I-5160) LH	2	
	454 815	C	CLAMP - (H. I-1400) LH	2	
-24	460 630	A	AIR FILTER - (CA144PL)	2	

- A - Not used when Turbocharger is installed. Refer to Rajay Corporation Parts Catalog.
- B - Used on PA-30 with serial numbers 30-2 to 30-1716 inclusive, 30-1718 to 30-1744 inclusive.
- C - Used on PA-30 with serial numbers 30-1717, 30-1745 and up. and PA-39 with serial numbers 39-1 and up.
- D - Order Part No. 25973-00 if existing flat type exhaust stack hanger has been replaced by hose type hanger.
- E - Used on PA-30 with counter-rotating right engine.
- F - Used if hose type exhaust stack hanger is installed.
- G - Used when fuel pump No. 73870 is installed.
- H - Used when fuel pump No. 74999 is installed.
- Y - Used on PA-30 airplanes only.
- Z - Used on PA-39 airplanes only.

When ordering, always specify Part Number, Description and Serial Number of Aircraft



Figure and Index Number	Part Number	Code	NOMENCLATURE	No. Req	SERIAL NUMBERS AFFECTED
35-25	450 929	BCY	PROPELLER - (HC-E2YL-2/7663-4)	2	
	450 929	BDZ	PROPELLER - Left (HC-E2YL-2/7663-4)	1	39-1 to 39-72 inclusive
	550 916	BZ	PROPELLER - Left (HC-E2YL-2BS/7663-4)	1	39-73 and up
	550 911	BDZ	PROPELLER - Right (HC-E2YL-2BL/J7663-4)	1	39-1 to 39-72 inclusive
	550 915	BZ	PROPELLER - Right (HC-E2YL-2BLS/J7663-4)	1	39-73 and up
-26	475 116		MOUNT ASSEMBLY - Top rear and bottom front (J-7763-1)	8	
	475 117		MOUNT ASSEMBLY - Top front and bottom rear (J-9612-8)	8	
-27	23850-08	A	STACK ASSEMBLY - Engine exhaust, right side front	2	
-28	23850-10		STACK ASSEMBLY - Engine exhaust, left side front	2	
-29	23850-11	A	STACK ASSEMBLY - Engine exhaust, right side rear	2	
-30	23850-12	AY	STACK ASSEMBLY - Engine exhaust, left side rear	2	30-2 to 30-1654 inclusive
	23850-14	AYZ	STACK ASSEMBLY - Engine exhaust, left side rear	2	30-1655 and up. 39-1 and up
-31	476 684		NIPPLE - (AN816-6-6)	2	
-32	458 867		ELBOW - (AN822-6-6D)	4	
-33	458 892		ELBOW - (AN823-6D)	2	
-34	453 617		BUSHING - (AN912-2D)	2	
-35	401 410		BOLT - (AN6-31A)	8	
-36	401 311		BOLT - (AN4-11A)	4	
	407 565		WASHER - (AN960-416)	12	
	404 836		NUT - (MS20364-428C)	4	
-37	400 004		BOLT - (AN4-7A)	4	
	407 565		WASHER - (AN960-416)	4	
	404 836		NUT - (MS20364-428C)	4	

- A - Not used when Turbocharger is installed. Refer to Rajay Corporation Parts Catalog.
- B - See Figure 35A for component parts.
- C - Not available. Order one of the following propellers which incorporates a Spring Back-Up Kit. The opposite propeller must also include the Spring Back-Up Kit per Piper Service Letter No. 564 and Hartzell Service Letter No. 62. If Counter-rotating Power Plant Conversion Kit has been installed, order propeller Part No. 550 915 (HC-E2YL-2BLS/J7663-4) for the right engine or propeller Part No. 550 916 (HC-E2YL-2BS/7663-4) for the left engine. If Counter-rotating Power Plant Conversion Kit has not been installed, order propeller Part No. 550 916 (HC-E2YL-2BS/7663-4) for either the left or right engine.
- D - Not available. Order propeller for serial numbers 39-73 and up which incorporates a Spring Back-Up Kit. The opposite propeller must also include the Spring Back-Up Kit per Piper Service Letter No. 564 and Hartzell Service Letter No. 62.
- Y - Used on PA-30 airplanes only.
- Z - Used on PA-39 airplanes only.

When ordering, always specify Part Number, Description and Serial Number of Aircraft



Figure and Index Number	Part Number	Code	NOMENCLATURE	No. Req	SERIAL NUMBERS AFFECTED
35-38	401 550		BOLT - (AN7-50A)	8	
-39	400 463		BOLT - Oil cooler (AN3-40A)	8	
-40	401 919		BOLT - (AN74A-4)	8	
-41	454 997		CLAMP - Wire grip (H1-1160)	4	
-42	554 803	A	CLAMP - Wire grip (H3-3800)	+	
-43	554 804	A	CLAMP - Wire grip (H3-3800)	4	
-44	454 881		CLAMP - Engine breather hose	2	
-45	23789-00	A	BAFFLE ASSEMBLY - Engine, right side front	2	
-46	23807-00	Y	BAFFLE ASSEMBLY - Engine, front center	2	30-2 to 30-541 inclusive
	23807-12	YZ	BAFFLE ASSEMBLY - Engine, front center	2	30-542 and up, 39-1 and up
-47	23849-00	Y	BAFFLE ASSEMBLY - Engine, left front	2	30-2 to 30-541 inclusive
	23849-04	YZ	BAFFLE ASSEMBLY - Engine, left front	2	30-542 and up, 39-1 and up
	23860-00	E	BAFFLE ASSEMBLY - Engine, right front	2	
	26579-00	C	BAFFLE ASSEMBLY - Engine, right front	2	
-48	14265-17		GROMMET - Caterpillar	2	
-49	23866-00	Y	BAFFLE ASSEMBLY - Engine, rear center	2	30-2 to 30-541 inclusive
	23866-04	YZ	BAFFLE ASSEMBLY - Engine, rear center	2	30-542 and up, 39-1 and up
-50	23907-00	Y	BAFFLE ASSEMBLY - Engine, right rear	2	30-2 to 30-541 inclusive
	23907-07	YZ	BAFFLE ASSEMBLY - Engine, right rear	2	30-542 and up, 39-1 and up
-51	23854-00		BAFFLE ASSEMBLY - Engine, left side front	2	
-52	23977-09		BAFFLE ASSEMBLY - Engine, left rear	2	
-53	10467-06		ROD - Engine baffle tie	4	
-54	418 419		SCREW - Cap	20	
-55	418 421		SCREW - Cap	2	
-56	21226-00		PLATE - Air scoop attachment	2	
-57	10525-95		HOSE - Fuel pump cooling	2	
-58	85012-101	A	WASHER	8	
-59	487 428		SPACER - Mount assembly (J-7766-2)	8	
-60	26890-00	C	TUBE ASSEMBLY - Alternator cooling	1	
-61	451 900	DZ	ADAPTER - Tachometer drive reverser (1A-11, 100)	1	
-62	23845-00		TUBE - Oil breather	2	
-63	581 700	B	PLACARD - Propeller pressure warning (CA-003)	2	

- A - Not used when Turbocharger is installed. Refer to Rajay Corporation Parts Catalog.
- B - Used with HC-2YL-2BS/7663-4 and HC-2YL-2BLS/J7663-4 propellers only.
- C - Used on PA-30 with serial numbers 30-1717, 30-1745 and up, and PA-39 with serial numbers 39-1 and up.
- D - Used on PA-30 with counter-rotating right engine.
- E - Used on PA-30 with serial numbers 30-2 to 30-1716 inclusive, 30-1718 to 30-1744 inclusive.
- Y - Used on PA-30 airplanes only.
- Z - Used on PA-39 airplanes only.

When ordering, always specify Part Number, Description and Serial Number of Aircraft

**1 J6**  
**INTENTIONALLY LEFT BLANK**

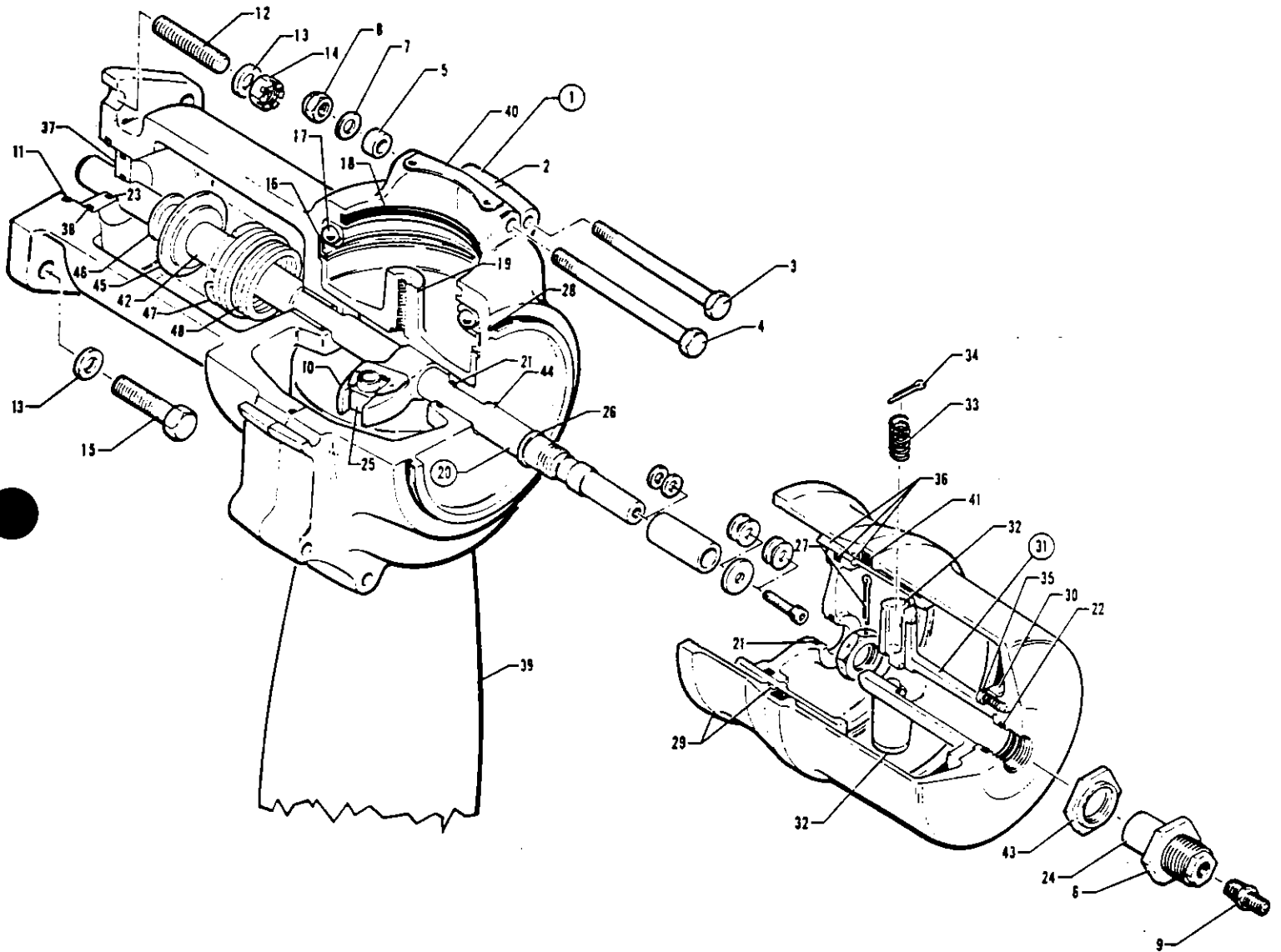

Figure 35A. Propeller Assembly

REVISED. MAY 1980

1J7

PA-30  
PA-39

PIPER PARTS CATALOG

Figure and Index Number	Part Number	Code	NOMENCLATURE	No. Req.	SERIAL NUMBERS AFFECTED	
35A-1	450 929	AY	PROPELLER ASSEMBLY - (HC-E2YL-2( )/7663-4)	2		
	450 929	BZ	PROPELLER ASSEMBLY - (HC-E2YL-2( )/7663-4) Left	1	39-1 to 39-72 inclusive	
	550 916	BZ	PROPELLER ASSEMBLY - (HC-E2YL-2BS/7663-4) Left	1	39-73 to 39-155 incl.	
	550 929	Z	PROPELLER ASSEMBLY - (HC-E2YL-2BSF/F7663-4) Left	1		
	550 911	BZ	PROPELLER ASSEMBLY - (HC-E2YL-2BL/J7663-4) Right	1	39-1 to 39-72 inclusive	
	550 915	BZ	PROPELLER ASSEMBLY - (HC-E2YL-2BLS/J7663-4) Right	1	39-73 to 39-155 incl.	
	550 930	Z	PROPELLER ASSEMBLY - (HC-E2YL-2BLSF/FJ7663-4) Right	1		
	-2	751 980	C	* HUB ASSEMBLY - Propeller (D-2483)	1	
		755 224	D	* HUB ASSEMBLY - Propeller (D-2483F)	1	
	-3	753 461		* BOLT - Hex head (A-2431)	6	
	-4	753 462		* BOLT - Hex head (A-2433)	4	
	-5	756 284		* SPACER - (A-2246-4)	4	
	-6	752 510		* NUT - Check (A-2405-1)	1	
	-7	407 567		* WASHER - (AN960-616)	10	
	-8	752 511		* NUT - Elastic (A-2043)	10	
	-9	756 510		* AIR VALVE - Schrader (A625)	1	
	-10	751 820	CE	* FORK UNIT - Pitch change (B-2457-2)	1	
		754 826	D	* FORK UNIT - Pitch change (B-2457-3)	1	
	-11	755 800		* "O" RING - Shaft (PRP-909-6)	1	
-12	756 285		* STUD - Flange (A-2247-1)	2		
-13	756 602		* WASHER - (A-2482)	6		
-14	752 512		* NUT - Castle (A-2498)	2		
-15	751 426		* BOLT - Hex head (A-988)	4		
-16	755 968		* RING - Bearing guide (A-2204)	2		
-17	753 463		* BEARING - Split (A-2202)	2		
-18	755 934		* "O" RING - Blade (PRP-902-42)	2		
-19	757 249		* PRELOAD PLATE UNIT - (B-2256)	2		
			<p>A - Not available. Order one of the following propellers which incorporates a spring back-up kit. The opposite propeller must also include the spring back-up kit per Piper Service Letter No. 564 and Hartzell Service Letter No. 62. If Counter-Rotating Power Plant Conversion Kit has been installed, propeller part no. 550 930 (#HC-E2YL-2BLSF/FJ7663-4) for the right engine or propeller part no. 550 929 (#HC-E2YL-2BSF/F7663-4) for the left engine. If Counter-Rotating Power Plant Conversion Kit has not been installed, order propeller part no. 550 929 (#HC-E2YL-2BSF/F7663-4) for either the left or right engine.</p> <p>B - Not available. Order propeller part no. 550 929 or part no. 550 930 which incorporates a spring back-up kit. The opposite propeller must also include the spring back-up kit per Piper Service Letter No. 564 and Hartzell Service Letter No. 62.</p> <p>C - Used with propeller assemblies HC-E2YL-2( )/7663-4, HC-E2YL-2BS/7663-4, HC-E2YL-2BL/J7663-4 and HC-E2YL-2BLS/J7663-4.</p> <p>D - Used with propeller assemblies HC-E2YL-2BSF/F7663-4 and HC-E2YL-2BLSF/FJ7663-4.</p> <p>E - No longer available. Order fork unit part no. 754 826 (B-2457-3) and two (2) blocks part no. 758 422 (A-2217-4) for replacement.</p> <p>Y - Used on PA-30 airplanes only.</p> <p>Z - Used on PA-39 airplanes only.</p>			

When ordering, always specify Part Number, Description and Serial Number of Aircraft



PIPER PARTS CATALOG

Figure and Index Number	Part Number	Code	NOMENCLATURE	No. Req.	SERIAL NUMBERS AFFECTED
35A-20	755 989	C	* ROD UNIT ASSEMBLY - Piston (A-3240-1)	1	
-21	752 713		* * "O" RING - (PRP-902-15)	2	
-22	755 933		* * "O" RING - Stop seal (PRP-914-17)	1	
-23	755 932		* * "O" RING - Plug (PRP-902-13)	1	
-24	756 293		* * LOW STOP - (A-2404-1)	1	
-25	753 464	P	* BLOCK - Pitch change (A-2217-1)	2	
	753 465	P	* BLOCK - Pitch change (A-2217-2)	2	
	758 204	K	* BLOCK - Pitch change (A-2217-3)	2	
	758 422	J	* BLOCK - Pitch change (A-2217-4)	2	
-26	755 972	A	* SPLIT RETAINER - (A2430)	1	
-27	424 061	A	* COTTER PIN - (AN380-3-5)	1	
-28	755 935		* "O" RING - Cylinder mounting (PRP-909-25)	1	
-29	753 982		* CYLINDER UNIT - (B-2423-1)	1	
-30	753 467	F	* BRACKET - High stop (B-2406-1)	1	
-31	753 466	AB	* HIGH PITCH STOP ASSEMBLY - (830-20)	1	
-32	757 251		* * PIN - High stop (A-2407-2)	4	
-33	756 242		* * SPRING - High stop (A-884)	4	
-34	424 061		* * COTTER PIN - High stop (AN380-3-5)	4	
-35	756 286		* SCREW - Filister head (AN501A416-10)	4	
	756 287	AB	* SCREW - Filister head (AN501A10-12)	6	
-36	757 250	ABG	* PISTON UNIT - (B-2486)	1	
	757 321	H	* PISTON UNIT - (B-3237)	1	
-37	757 253		* PLUG - Shaft (A-2481)	1	
-38	755 931		* "O" RING - Plug (PRP-909-4)	1	
-39	753 495	LY	* BLADE - Propeller (7663-4)	2	
	758 198	MY	* BLADE - Propeller (F7663-4)	2	
	753 495	LZ	* BLADE - Propeller (7663-4) Left	2	
	758 198	MZ	* BLADE - Propeller (F7663-4) Left	2	
	758 178	DNZ	* BLADE - Propeller (J7663-4) Right	2	
	758 199	DEZ	* BLADE - Propeller (FJ7663-4) Right	2	

- A - Used with Propeller Assembly HC-E2YL-2.
- B - Used with Propeller Assembly HC-E2YL-2A.
- C - Used with Propeller Assemblies HC-E2YL-2( )/7663-4 and HC-E2YL-2BL/J7663-4 only.
- D - Used on PA-30 with counter-rotating right engine.
- E - Used with Propeller Assembly HC-E2YL-2BLSF/FJ7663-4.
- F - Used with Propeller Assembly HC-E2YL-2B.
- G - Used with Propeller Assembly HC-E2YL-2B with propeller serial numbers BG-1 to BG-3572 inclusive.
- H - Used with Propeller Assembly HC-E2YL-2B with propeller serial numbers BG-3573 and up, and Propeller Assemblies HC-E2YL-2BS, HC-E2YL-2BL and HC-E2YL-2BLS.
- J - Used with Propeller Assemblies HC-E2YL-2( )/7663-4, HC-E2YL-2BS/7663-4, HC-E2YL-2BS/J7663-4 and HC-E2YL-2BLS/J7663-4 if fork unit 751 820 has been replaced with fork unit 754 826.
- K - Used with Propeller Assemblies HC-E2YL-2BSF/F7663-4 and HC-E2YL-2BLSF/FJ7663-4.
- L - Used with Propeller Assembly HC-E2YL-2( )/7663-4.
- M - Used with Propeller Assembly HC-E2YL-2BSF/F7663-4.
- N - Used with Propeller Assemblies HC-E2YL-2BL/J7663-4 and HC-E2YL-2BLS/J7663-4.
- P - Used with Fork Unit B-2457-2 only.
- Y - Used on PA-30 airplanes only.
- Z - Used on PA-39 airplanes only.

When ordering, always specify Part Number, Description and Serial Number of Aircraft

PIPER PARTS CATALOG

Figure and Index Number	Part Number	Code	NOMENCLATURE	No. Req.	SERIAL NUMBERS AFFECTED
35A-40	756 607		• WEIGHT - Balance (A-2424)	AR	
-41	755 977		• "O" RING - Cylinder (A-3223)	1	
-42	757 645	D	• SPACER - Spring back-up	1	
-43	752 510	AB	• NUT - Check (A-2405-1)	1	
	752 515	C	• NUT - Check (A-2405)	1	
-44	756 040	D	• ROD UNIT - Piston (B-2491-4S)	1	
-45	756 041	D	• RETAINER - Spring	1	
-46	760 454	D	• KEEPER - Spring retainer	1	
-47	757 647	D	• SPRING - Spacer	1	
-48	757 646	D	• SPRING - Spacer	1	
			<p>A - Used with Propeller Assembly HC-E2YL-2.                      B - Used with Propeller Assembly HC-E2YL-2A.                      C - Used with Propeller Assemblies HC-E2YL-2B, HC-E2YL-2BS, HC-E2YL-2BL and HC-E2YL-2BLS.                      D - Used with Propeller Assemblies HC-E2YL-2BS/7663-4 and HC-E2YL-2BLS/J7663-4 only.</p>		

When ordering, always specify Part Number, Description and Serial Number of Aircraft

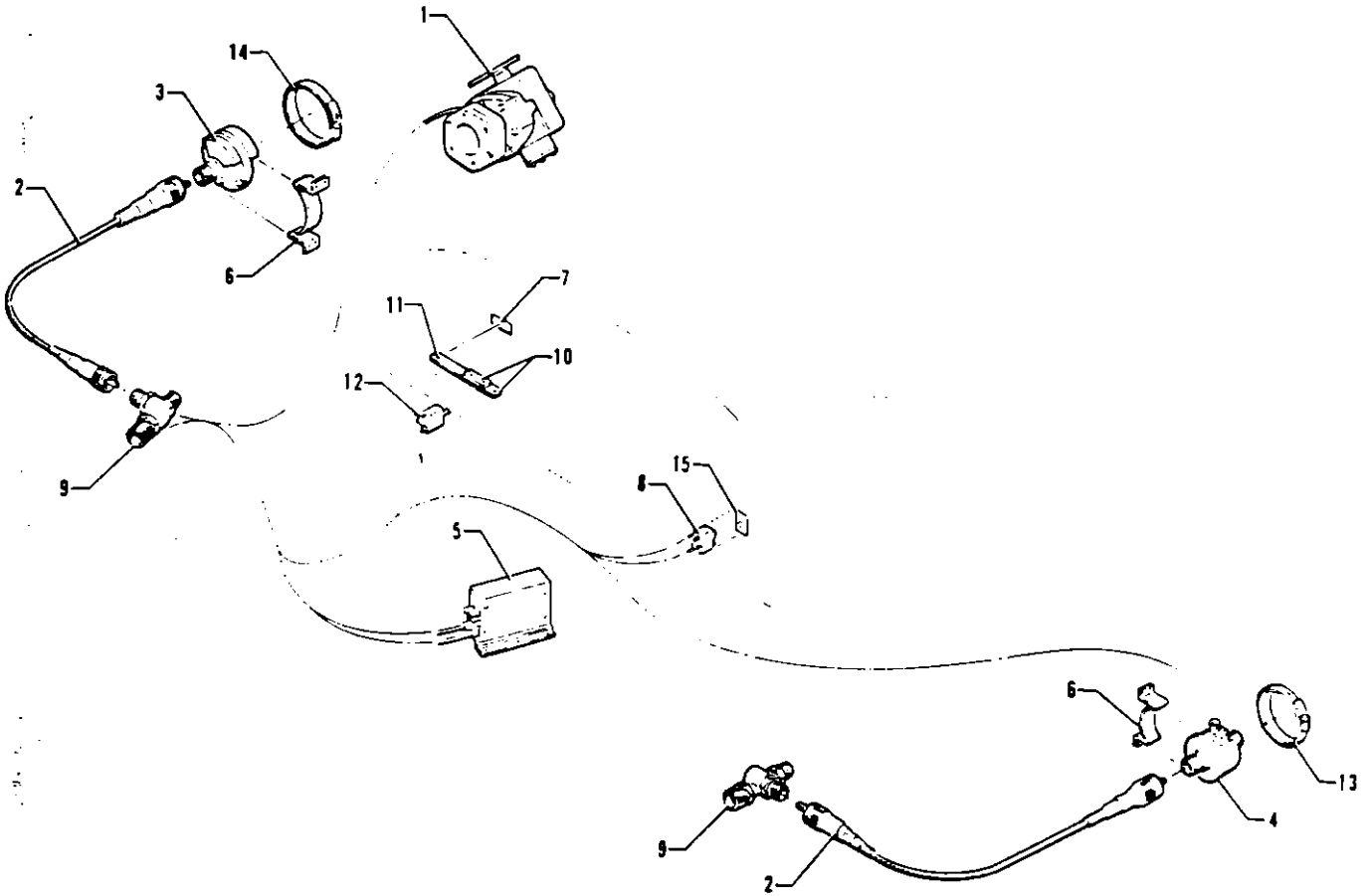

Figure 35B. Propeller Synchrophaser System Installation



Figure and Index Number	Part Number	Code	NOMENCLATURE	No. Req.	SERIAL NUMBERS AFFECTED
35B-	27243		DRAWING - Propeller Synchrophaser System Installation		
-1	16564-10	AY	GOVERNOR ASSEMBLY - Right (F-8-3A)	1	
	16564-09	Z	GOVERNOR ASSEMBLY - Right (F-8-3AL)	1	
-2	486 627		SHAFT ASSEMBLY - Tachometer (PS500044-16)	2	
-3	757 687		STROBE SENSOR - (C-3966)	1	
-4	757 375		PULSE GENERATOR ASSEMBLY - (B-3956)	1	
-5	757 946		COMPUTER ASSEMBLY - (D-3996)	1	
-6	27246-03		BRACKET - Propeller synchrophaser, left	1	
	27246-02		BRACKET - Propeller synchrophaser, right	1	
-7	27249-00		PLACARD - Propeller synchrophaser	1	
	27250-00		PLACARD - Propeller synchrophaser and tip tanks	1	
-8	487 790	B	SWITCH - Propeller synchrophaser (110-S-73)	1	
	32370-22	C	SWITCH - Propeller synchrophaser	1	
-9	52785-02		ADAPTER - Dual drive	2	
-10	31506-02		BAR - Bus (length 1 1/4")	2	
-11	31506-04		BAR - Bus (length 2 3/4")	1	
-12	454 656		CIRCUIT BREAKER - (109-205-102) 5 AMP	1	
-13	554 834		CLAMP - (SAE TY F-40)	1	
-14	554 731		CLAMP - (SAE TY F-56)	1	
-15	27447-00	B	PLACARD - "Prop Sync"	1	

A - Order Part No. 16564-09 if Counter-rotating Power Plant Conversion Kit has been installed.  
 B - Used on PA-30 with serial numbers 30-2 to 30-1716 inclusive, 30-1718 to 30-1744 inclusive.  
 C - Used on PA-30 with serial numbers 30-1717, 30-1745 and up, and PA-39 with serial numbers 39-1 and up.  
 Y - Used on PA-30 airplanes only.  
 Z - Used on PA-39 airplanes only.

When ordering, always specify Part Number, Description and Serial Number of Aircraft

PIPER PARTS CATALOG

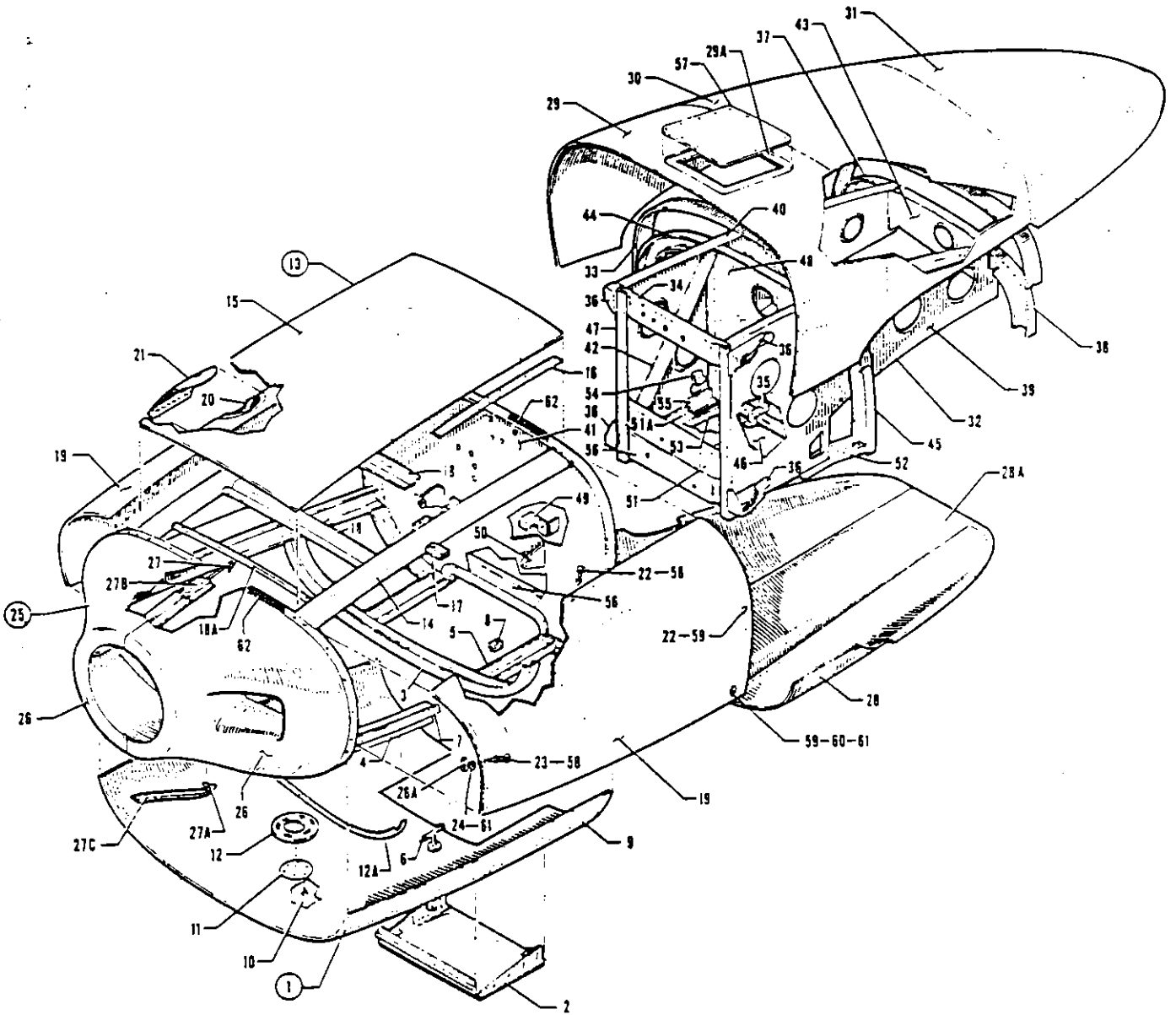

Figure 36. Engine Nacelle Installation



Figure and Index Number	Part Number	Code	NOMENCLATURE	No. Req.	SERIAL NUMBERS AFFECTED
36-	24533	Y	DRAWING - Nacelle Installation, Engine, Front		30-2 to 30-27 inclusive
	24108	A	DRAWING - Nacelle Installation, Engine, Front		
	25250	B	DRAWING - Nacelle Installation, Engine, Front		
	23540		DRAWING - Nacelle Installation, Engine		
-1	24533-06	Y	COWL ASSEMBLY - Engine nacelle, bottom, left engine	1	30-2 to 30-27 inclusive
	24108-12	A	COWL ASSEMBLY - Engine nacelle, bottom, left engine	1	
	25250-04	B	COWL ASSEMBLY - Engine nacelle, bottom, left engine	1	
	24533-05	Y	COWL ASSEMBLY - Engine nacelle, bottom, right engine	1	
	24108-11	A	COWL ASSEMBLY - Engine nacelle, bottom, right engine	1	
	25250-03	B	COWL ASSEMBLY - Engine nacelle, bottom, right engine	1	
-2	23842-00		FLAP ASSEMBLY - Cowl	1	
-3	23657-00		BULKHEAD - Engine cowl	1	
-4	23855-04	Y	CHANNEL ASSEMBLY - Engine cowl, LH	1	30-2 to 30-27 inclusive
	23855-00	A	CHANNEL ASSEMBLY - Engine cowl, LH	1	
	25232-00	B	CHANNEL ASSEMBLY - Engine cowl, LH	1	
	23855-05	Y	CHANNEL ASSEMBLY - Engine cowl, RH	1	
	23855-01	A	CHANNEL ASSEMBLY - Engine cowl, RH	1	
-5	25232-01	B	CHANNEL ASSEMBLY - Engine cowl, RH	1	30-2 to 30-27 inclusive
	23959-00	C	CHANNEL - Engine cowl reinforcement, LH	1	
	23959-01	C	CHANNEL - Engine cowl reinforcement, RH	1	
	25231-00	B	CHANNEL - Engine cowl reinforcement, LH	1	
-6	25231-01	B	CHANNEL - Engine cowl reinforcement, RH	1	
	24114-00		TUBE ASSEMBLY - Drain connector	1	
-7	180 807		WEBBING - Anti-squeak	61	
-8	24126-00		CLIP - Nacelle, LH	1	
	24126-01		CLIP - Nacelle, RH	1	
-9	24533-08	Y	SKIN ASSEMBLY - Engine nacelle, left engine	1	30-2 to 30-27 inclusive
	24108-14	YZ	SKIN ASSEMBLY - Engine nacelle, left engine	1	
	24533-07	Y	SKIN ASSEMBLY - Engine nacelle, right engine	1	
	24108-13	YZ	SKIN ASSEMBLY - Engine nacelle, right engine	1	
-10	414 763		SCREW - (AN507-832R8)	6	
-11	24118-00		PLATE - Nacelle access, 3" diameter	1	
	17318-03		PLATE - Nacelle access, 4-5/8" diameter	1	
-12	24119-00		PLATE ASSEMBLY - Nacelle reinforcement, 4" diameter	1	
	17317-00		PLATE ASSEMBLY - Nacelle reinforcement, 5-13/16" diameter	1	
-12a	25680-00		BULKHEAD - Engine nacelle, bottom	1	

A - Used on PA-30 with serial numbers 30-28 to 30-793, 30-799 to 30-901 inclusive.  
 B - Used on PA-30 with serial numbers 30-794 to 30-798, 30-902 and up. and PA-39 with serial numbers 39-1 and up.  
 C - Used on PA-30 with serial numbers 30-2 to 30-793, 30-799 to 30-901 inclusive.  
 Y - Used on PA-30 airplanes only.  
 Z - Used on PA-39 airplanes only.

When ordering, always specify Part Number, Description and Serial Number of Aircraft

PIPER PARTS CATALOG

Figure and Index Number	Part Number	Code	NOMENCLATURE	No. Req.	SERIAL NUMBERS AFFECTED
36-13	24533-02	Y	COWL ASSEMBLY - Engine nacelle, top	2	30-2 to 30-27 inclusive
	24108-02	A	COWL ASSEMBLY - Engine nacelle, top	2	
	25250-02	B	COWL ASSEMBLY - Engine nacelle, top	2	
-14	23862-06	Y	* CHANNEL ASSEMBLY - Engine cowl, LH	1	30-2 to 30-27 inclusive
	23862-00	A	* CHANNEL ASSEMBLY - Engine cowl, LH	1	
	25251-00	B	* CHANNEL ASSEMBLY - Engine cowl, LH	1	
	23862-05	Y	* CHANNEL ASSEMBLY - Engine cowl, RH	1	30-2 to 30-27 inclusive
	23862-01	A	* CHANNEL ASSEMBLY - Engine cowl, RH	1	
	25253-00	B	* CHANNEL ASSEMBLY - Engine cowl, RH	1	
-15	24532-04	Y	* SKIN - Engine nacelle	1	30-2 to 30-27 inclusive
	23867-04	YZ	* SKIN - Engine nacelle	1	30-28 and up, 39-1 and up
-16	180 807		* WEBBING - Anti-squeak	5*	
-17	10016-57		* STRIP - Felt	4	
-18	24167-02		* CHANNEL - Nacelle reinforcement	2	
-18a	25691-00		* BULKHEAD - Engine nacelle, top	1	
-19	24533-04	Y	COWL ASSEMBLY - Engine nacelle, side, LH	1	30-2 to 30-27 inclusive
	24108-04	A	COWL ASSEMBLY - Engine nacelle, side, LH	1	
	25245-00	B	COWL ASSEMBLY - Engine nacelle, side, LH	1	
	24533-03	Y	COWL ASSEMBLY - Engine nacelle, side, RH	1	30-2 to 30-27 inclusive
	24108-03	A	COWL ASSEMBLY - Engine nacelle, side, RH	1	
	25245-01	B	COWL ASSEMBLY - Engine nacelle, side, RH	1	
-20	24077-00		* PLATE - Engine nacelle reinforcement, RH	1	
-21	24107-00		* PLATE ASSEMBLY - Engine nacelle access, RH	1	
-22	487 659	C	* STUD - (#2-F-120)	23	
-23	487 669	C	* STUD - (#2-F-160)	4	
-24	484 482	C	* RING - Retainer	27	
-25	24029-00	C	COWL ASSEMBLY - Nose	2	
	25247-00	D	COWL ASSEMBLY - Nose	2	
	25247-06	E	COWL ASSEMBLY - Nose	2	
-26	24029-11	C	* COWL ASSEMBLY - Left engine outboard, right engine inboard	1	
	25247-04	B	* COWL ASSEMBLY - Left engine outboard, right engine inboard	1	
	24029-12	C	* COWL ASSEMBLY - Left engine inboard, right engine outboard	1	
	25247-05	D	* COWL ASSEMBLY - Left engine inboard, right engine outboard	1	
	25247-08	E	* COWL ASSEMBLY - Left engine inboard, right engine outboard	1	
-26a	484 322	C	* * RECEPTACLE - (#82-35-302-15)	4	
	484 310	B	* * RECEPTACLE - (#244-16)	4	

- A - Used on PA-30 with serial numbers 30-28 to 30-793, 30-799 to 30-901 inclusive.
- B - Used on PA-30 with serial numbers 30-794 to 30-798, 30-902 and up, and PA-39 with serial numbers 39-1 and up.
- C - Used on PA-30 with serial numbers 30-2 to 30-793 inclusive, 30-799 to 30-901 inclusive.
- D - Used on PA-30 with serial numbers 30-794 to 30-798 inclusive, 30-902 to 30-1716 inclusive, 30-1718 to 30-1744 inclusive.
- E - Used on PA-30 with serial numbers 30-1717, 30-1745 and up, and PA-39 with serial numbers 39-1 and up.
- Y - Used on PA-30 airplanes only.
- Z - Used on PA-39 airplanes only.

When ordering, always specify Part Number, Description and Serial Number of Aircraft



Figure and Index Number	Part Number	Code	NOMENCLATURE	No. Req	SERIAL NUMBERS AFFECTED
36-27	24055-04		PIN - Hinge, upper	1	
-27a	24057-04		PIN - Hinge, lower	1	
-27b	24055-03		HINGE - Nose cowl, upper, left engine outboard, right engine inboard	1	
	24055-02		HINGE - Nose cowl, upper, left engine inboard, right engine outboard	1	
-27c	24057-03		HINGE - Nose cowl, lower, left engine outboard, right engine inboard	1	
	24057-02		HINGE - Nose cowl, lower, left engine inboard, right engine outboard	1	
-28	23539-00		SKIN ASSEMBLY - Nacelle, LH	1	
	23539-01		SKIN ASSEMBLY - Nacelle, RH	1	
-28a	23512-00		SHIELD ASSEMBLY - Exhaust heat, LH	1	
	23512-01		SHIELD ASSEMBLY - Exhaust heat, RH	1	
-29	23540-26		SKIN ASSEMBLY - Nacelle, front, LH	1	
	23540-25		SKIN ASSEMBLY - Nacelle, front, RH	1	
-29a	23983-00		PLATE - Nacelle reinforcement	1	
-30	23555-08		SKIN - Nacelle, center, LH	1	
	23555-09		SKIN - Nacelle, center, RH	1	
-31	23555-10		SKIN - Nacelle, aft, LH	1	
	23555-11		SKIN - Nacelle, aft, RH	1	
-32	23568-00	B	FRAME ASSEMBLY - Nacelle, aft section, LH	1	
	23568-08	C	FRAME ASSEMBLY - Nacelle, aft section, LH	1	
	23568-01	B	FRAME ASSEMBLY - Nacelle, aft section, RH	1	
	23568-09	C	FRAME ASSEMBLY - Nacelle, aft section, RH	1	
-33	23568-04		STRIP ASSEMBLY - LH	1	
	23568-05		STRIP ASSEMBLY - RH	1	
-34	23484-00		CHANNEL - Firewall	1	
-35	23906-00		BRACKET - Tube support	1	
-36	23485-00		BRACKET ASSEMBLY - Engine mount attachment, left engine, right top and left bottom and right engine, left top and right bottom	1	
	23485-01		BRACKET ASSEMBLY - Engine mount attachment, left engine, left top and right bottom and right engine, right top and left bottom	1	
-37	23486-00		BULKHEAD ASSEMBLY - Nacelle, aft, inboard, LH	1	
	23486-01		BULKHEAD ASSEMBLY - Nacelle, aft, inboard, RH	1	
-38	23495-00		BULKHEAD ASSEMBLY - Nacelle, aft, outboard, LH	1	
	23495-01		BULKHEAD ASSEMBLY - Nacelle, aft, outboard, RH	1	
-39	23496-00		BULKHEAD ASSEMBLY - Nacelle, longitudinal, outboard, LH	1	
	23496-01		BULKHEAD ASSEMBLY - Nacelle, longitudinal, outboard, RH	1	
-40	23513-00		BULKHEAD ASSEMBLY - Nacelle, longitudinal, inboard, LH	1	
	23513-01		BULKHEAD ASSEMBLY - Nacelle, longitudinal, inboard, RH	1	
			A - Items 28 to 40 inclusive are component parts of Wing Panel Assembly.		
			B - Used on PA-30 with serial numbers 30-2 to 30-793, 30-794 to 30-901 inclusive.		
			C - Used on PA-30 with serial numbers 30-794 to 30-798, 30-902 and up. and PA-39 with serial numbers 39-1 and up.		

When ordering, always specify Part Number, Description and Serial Number of Aircraft



PIPER PARTS CATALOG

Figure and Index Number	Part Number	Code	NOMENCLATURE	No. Req.	SERIAL NUMBERS AFFECTED
36-41	23528-00	C	* FIREWALL ASSEMBLY - LH	1	
	25249-00	B	* FIREWALL ASSEMBLY - LH	1	
	23528-01	C	* FIREWALL ASSEMBLY - RH	1	
	25249-01	B	* FIREWALL ASSEMBLY - RH	1	
-42	23532-00		* ANGLE - Bulkhead stiffener, right engine front, left	1	
	23532-01		* ANGLE - Bulkhead stiffener, right engine front, right	1	
	23532-01		* ANGLE - Bulkhead stiffener, left engine front, left	1	
	23532-00		* ANGLE - Bulkhead stiffener, left engine front, right	1	
-43	23533-00		* BULKHEAD ASSEMBLY - Nacelle, aft, center, LH	1	
	23533-01		* BULKHEAD ASSEMBLY - Nacelle, aft, center, RH	1	
-44	23549-00		* BULKHEAD - Nacelle, inboard, LH	1	
	23549-01		* BULKHEAD - Nacelle, inboard, RH	1	
-45	23550-00		* BULKHEAD - Nacelle, outboard, LH	1	
	23550-01		* BULKHEAD - Nacelle, outboard, RH	1	
-46	23556-02		* BRACKET - Firewall support, LH	1	
	23556-03		* BRACKET - Firewall support, RH	1	
-47	23570-01		* ANGLE - Firewall support, left engine, left	1	
	23570-00		* ANGLE - Firewall support, left engine, right	1	
	23570-00		* ANGLE - Firewall support, right engine, left	1	
	23570-01		* ANGLE - Firewall support, right engine, right	1	
-48	23572-00		* BULKHEAD - Nacelle, center, LH	1	
	23572-01		* BULKHEAD - Nacelle, center, RH	1	
-49	24013-00		* BRACKET - Cowl flap control	2	
-50	24012-01		* BRACKET ASSEMBLY - Cowl flap torque tube mounting, left engine, left	1	
	24012-00		* BRACKET ASSEMBLY - Cowl flap torque tube mounting, left engine, right	1	
	24012-00		* BRACKET ASSEMBLY - Cowl flap torque tube mounting, right engine, left	1	
	24012-01		* BRACKET ASSEMBLY - Cowl flap torque tube mounting, right engine, right	1	
-51	24208-00		* CHANNEL ASSEMBLY - Firewall	2	
-51a	23556-06		* ANGLE - Firewall support, left nacelle, outboard	1	
	23556-04		* ANGLE - Firewall support, left nacelle, inboard	1	
	23556-07		* ANGLE - Firewall support, right nacelle, outboard	1	
	23556-05		* ANGLE - Firewall support, right nacelle, inboard	1	
-52	23576-00		PLATE - Nacelle tie, LH	1	
	23576-01		PLATE - Nacelle tie, RH	1	
-53	23577-00		PLATE - Nacelle tie, LH	1	
	23577-01		PLATE - Nacelle tie, RH	1	
-54	23685-00		ANGLE - Wire harness conduit support, LH	1	
	23685-01		ANGLE - Wire harness conduit support, RH	1	
-55	23795-00		ANGLE - Tube block attachment	1	
-56	24371-00		CHANNEL - Firewall	1	
-57	23540-24		PLATE - Nacelle reinforcement	1	
-58	487 684	B	STUD - (#4002-7)	12	
-59	487 689	B	STUD - (#4002-6)	30	
-60	463 400	B	GROMMET - (#4002-0)	42	
-61	484 755	B	SNAP RING - (R4G)	42	
-62	180 806		WEBBING - Anti-squeak	6	

A - Items 41 to 57 inclusive are component parts of Wing Panel Assembly.  
 B - Used on PA-30 with serial numbers 30-794 to 30-798, 30-902 and up, and PA-39 with serial numbers 39-1 and up.  
 C - Used on PA-30 with serial numbers 30-2 to 30-793, 30-799 to 30-901 inclusive.

When ordering, always specify Part Number, Description and Serial Number of Aircraft

**1 J18**

**INTENTIONALLY LEFT BLANK**

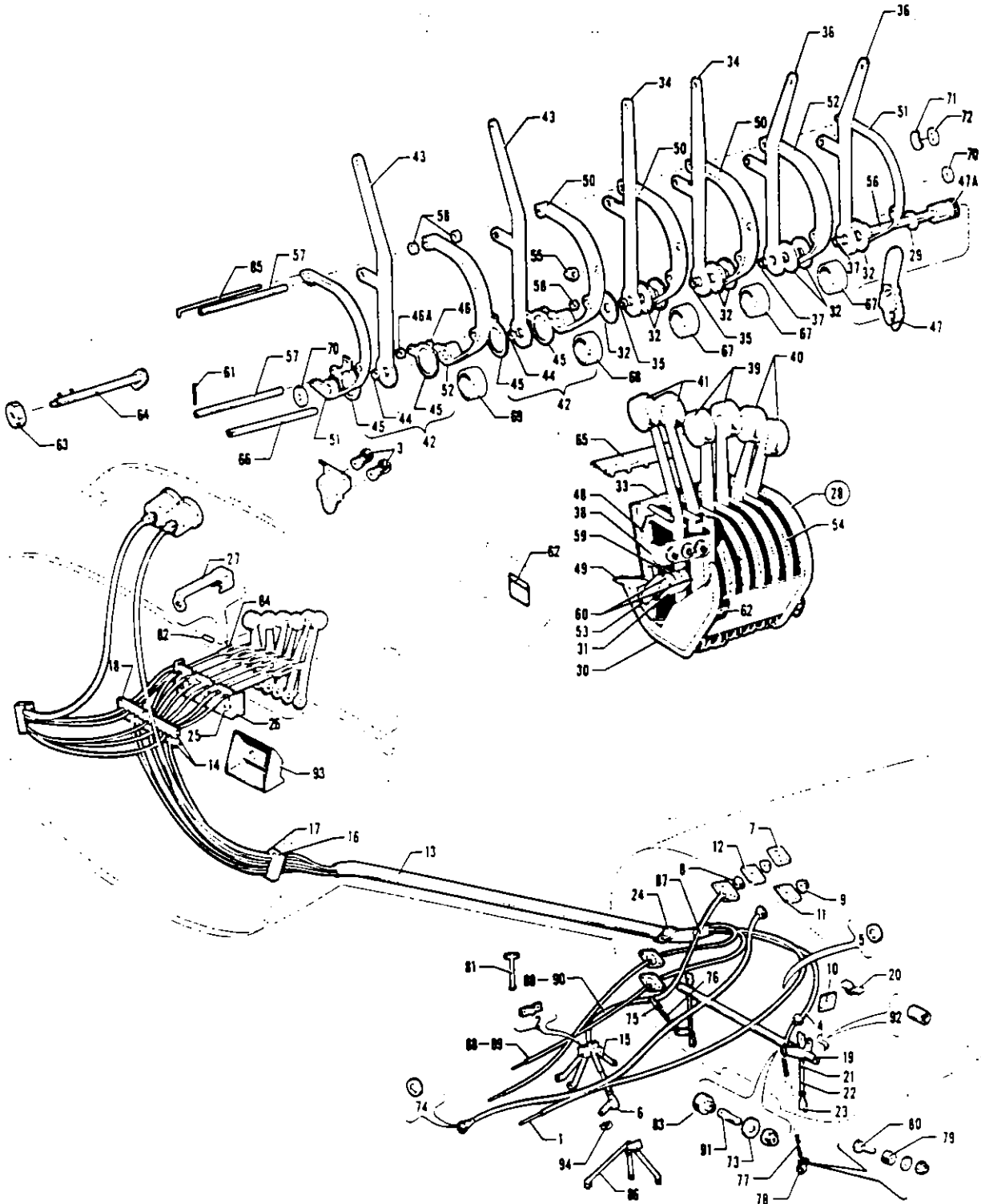

Figure 37. Engine Controls Installation

REVISED: FEBRUARY 1977

**1 J19**

PA-30  
PA-39



Figure and Index Number	Part Number	Code	NOMENCLATURE	No. Req.	SERIAL NUMBERS AFFECTED
37-	24090 26755	A B	DRAWING - Controls Installation, Engine DRAWING - Controls Installation, Engine		
-1	17969-09		CABLE ASSEMBLY - Air induction control	2	
-2	18219-02		CLAMP - Control cable attachment	6	
-3	471 064 571 105	A B	KNOB - Alternate air, black (#222) KNOB - Alternate air, black (#110204)	2 2	
-4	19331-02		CABLE ASSEMBLY - Cowl flap control	2	
-5	19513-24		WASHER - Air induction cable	2	
-6	31747-00		JOINT ASSEMBLY - Ball	6	
-7	22103-02		PLATE - Firewall seal grommet	4	
-8	22104-03		GROMMET - Firewall seal, red	16	
-9	22104-07		GROMMET - Firewall seal, green	4	
-10	22105-03		GASKET - Firewall seal	2	
-11	22105-05		GASKET - Firewall seal	2	
-12	22105-06		GASKET - Firewall seal	6	
-13	23682-00 23682-01		TUBE - Engine control cable guide, LH TUBE - Engine control cable guide, RH	1 1	
-14	23749-00		BLOCK - Control cable guide	2	
-15	23811-00		BRACKET ASSEMBLY - Mixture control support	2	
-16	23830-02		BLOCK - Control cable guide	2	
-17	23830-03		BLOCK - Control cable guide	2	
-18	23832-00		BLOCK - Control cable guide	2	
-19	24010-00 25369-00	Y YZ	TUBE ASSEMBLY - Cowl flap control torque TUBE ASSEMBLY - Cowl flap control torque	2 2	30-2 to 30-829 inclusive 30-830 and up, 39-1 and up
-20	24014-00		CLAMP - Cowl flap control torque	2	
-21	24016-00 24362-00		ROD ASSEMBLY - Cowl flap control, right ROD ASSEMBLY - Cowl flap control, left	2 2	
-22	24016-02 24362-02		ROD - Cowl flap support, right ROD - Cowl flap support, left	1 1	
-23	554 757 454 901		CLEVIS - Right (MS35812-1) CLEVIS - Left	2 2	
-24	24074-00		CLAMP - Tube support	2	
-25	24081-00		CLIP - Control retaining	3	
-26	24082-00		BRACKET ASSEMBLY - Engine control support	1	
-27	24123-00		CLIP - Pin retainer	6	
-28	24135-00 26481-00	A B	QUADRANT ASSEMBLY QUADRANT ASSEMBLY	1 1	
-29	14976-95	A	BUSHING	1	
-30	16569-74	A	WELT ASSEMBLY	2	
-31	18418-02		PLATE - Throttle switch actuator	1	
-32	19513-63 17852-03	A B	WASHER PLATE - Friction, outboard	12 2	
	17852-02	B	PLATE - Friction, outboard	10	
-33	19940-00	A	PLACARD - Operating limitations	1	

A - Used on PA-30 with serial numbers 30-2 to 30-1716 inclusive, 30-1718 to 30-1744 inclusive.  
 B - Used on PA-30 with serial numbers 30-1717, 30-1745 and up, and PA-39 with serial numbers 39-1 and up.  
 Y - Used on PA-30 airplanes only.  
 Z - Used on PA-39 airplanes only.

When ordering, always specify Part Number, Description and Serial Number of Aircraft



Figure and Index Number	Part Number	Code	NOMENCLATURE	No. Req.	SERIAL NUMBERS AFFECTED
37-34	23738-00	A	LEVER ASSEMBLY - Propeller control, LH	1	
	23738-06	B	LEVER ASSEMBLY - Propeller control, LH	1	
	23738-01	A	LEVER ASSEMBLY - Propeller control, RH	1	
	23738-07	B	LEVER ASSEMBLY - Propeller control, RH	1	
-35	23737-00		BEARING	1	
-36	23740-03	A	LEVER ASSEMBLY - Mixture control, LH	1	
	23740-09	B	LEVER ASSEMBLY - Mixture control, LH	1	
	23740-02	A	LEVER ASSEMBLY - Mixture control, RH	1	
	23740-08	B	LEVER ASSEMBLY - Mixture control, RH	1	
-37	23737-00		BEARING	1	
-38	23746-00		CHANNEL ASSEMBLY - Control lever stop	1	
-39	24047-00		KNOB - Propeller control	2	
-40	24048-00		KNOB - Mixture control	2	
-41	24049-00		KNOB - Throttle control	2	
-42	24122-00	A	LEVER ASSEMBLY - Throttle complete, LH	1	
	24122-02	B	LEVER ASSEMBLY - Throttle complete, LH	1	
	24122-01	A	LEVER ASSEMBLY - Throttle complete, RH	1	
	24122-03	B	LEVER ASSEMBLY - Throttle complete, RH	1	
-43	23744-02	A	LEVER ASSEMBLY - Throttle, LH	1	
	23744-06	B	LEVER ASSEMBLY - Throttle, LH	1	
	23744-03	A	LEVER ASSEMBLY - Throttle, RH	1	
	23744-09	B	LEVER ASSEMBLY - Throttle, RH	1	
-44	23737-00		BEARING	1	
-45	24120-02	A	PLATE - Throttle switch actuator	2	
	24120-04	B	PLATE - Throttle switch actuator	2	
-46	61402-64		BUSHING	2	
-46a	61402-64	A	BUSHING	1	
	27064-00	B	BUSHING - Shoulder, eccentric	1	
-47	24358-00		HANDLE ASSEMBLY - Quadrant adjusting	1	
-47a	24357-00		NUT - Quadrant adjusting	1	
-48	24130-00	A	PLATE ASSEMBLY - Quadrant side, left	1	
	26424-00	B	PLATE ASSEMBLY - Quadrant side, left	1	
	24130-01	A	PLATE ASSEMBLY - Quadrant side, right	1	
	26425-00	B	PLATE ASSEMBLY - Quadrant side, right	1	
-49	24134-00	A	PANEL ASSEMBLY - Quadrant cover, left	1	
	24133-00	A	PANEL ASSEMBLY - Quadrant cover, right	1	
	26455-02	B	COVER - Throttle quadrant, black	1	
	26458-03	B	COVER - Throttle quadrant, white	1	
	26458-04	B	COVER - Throttle quadrant, beige metallic	1	
-50	24139-01	A	SEGMENT - Control quadrant	3	
	26380-02	B	SEGMENT - Control quadrant	3	
-51	24136-00	A	SEGMENT - Control quadrant, outside, left	1	
	24136-01	A	SEGMENT - Control quadrant, outside, right	1	
	26377-00	B	SEGMENT - Control quadrant, outside, left and right	2	
-52	24139-00	A	SEGMENT - Control quadrant	2	
	26380-00	B	SEGMENT - Control quadrant	2	
-53	24154-00		PLATE - Switch insulator	1	

A - Used on PA-30 with serial numbers 30-2 to 30-1716 inclusive. 30-1718 to 30-1744 inclusive.

B - Used on PA-30 with serial numbers 30-1717, 30-1745 and up. and PA-39 with serial numbers 39-1 and up.

When ordering, always specify Part Number, Description and Serial Number of Aircraft

PIPER PARTS CATALOG

Figure and Index Number	Part Number	Code	NOMENCLATURE	No. Req.	SERIAL NUMBERS AFFECTED
37-54	24155-00	B	* PLACARD - Pedestal control	1	
	26451-00	C	* PLACARD - Throttle, control quadrant	1	
	26452-00	C	* PLACARD - Propeller, control quadrant	1	
	26456-00	C	* PLACARD - Mixture, control quadrant	1	
-55	494 082		* WASHER - Faucet	3	
-56	24124-00	B	* SHAFT - Quadrant control	1	
	26421-00	C	* SHAFT ASSEMBLY - Quadrant control	1	
-57	24161-00		* PIN - Quadrant	2	
-58	80022-100		* BUSHING	12	
-59	487 804		* SWITCH - Limit	1	
-60	487 940		* SWITCH - Limit	2	
-61	480 697	B	* PIN - Roll	1	
-62	24493-00		* PLACARD - Throttle cut-off	1	
-63	24492-00		* KNOB - Throttle cut-off release	1	
-64	24495-00	B	* SHAFT ASSEMBLY - Throttle cut-off release	1	
	24495-02	C	* SHAFT ASSEMBLY - Throttle cut-off release	1	
-65	26416-00	C	* STOP - Control lever	1	
-66	26417-00	C	* SPACER - Throttle quadrant	1	
-67	49999-05	C	* BUSHING - Throttle quadrant	3	
-68	49999-06	C	* BUSHING - Throttle quadrant	1	
-69	49999-07	C	* BUSHING - Throttle quadrant	1	
-70	80122-119	C	* WASHER - Throttle quadrant, left	1	
	80122-120	C	* WASHER - Throttle quadrant, right	1	
-71	408 827	C	* WASHER - Throttle quadrant (#3502-18-36)	1	
-72	407 566	C	* WASHER - Throttle quadrant (AN960-516)	1	
-73	81342-18		WASHER	4	
-74	85012-14		WASHER	4	
-75	81262-83		LINK - Air control cable	4	
-76	42891-00		SPRING - Air control cable	2	
-77	83302-65	YZ	SPRING - Cowl flap (487 455)	2	30-830 and up, 39-1 and up
-78	80032-20	YZ	CLAMP - Cowl flap spring	2	30-830 and up, 39-1 and up
-79	14175-05	YZ	BUSHING - Cowl flap spring	2	30-830 and up, 39-1 and up
-80	400 440	YZ	BOLT - (AN3-6A)	2	30-830 and up, 39-1 and up
	407 682	YZ	WASHER - (AN960-C10L)	2	30-830 and up, 39-1 and up
	404 973	YZ	NUT - (AN363-C1032)	2	30-830 and up, 39-1 and up
-81	25079-00	A	TUBE ASSEMBLY - Control cable guide	2	
-82	86092-82		PIN	6	
-83	91193-00		FITTING	4	
-84	488 327		TERMINAL - Clevis tie rod	6	
-85	24153-00		PIN - Quadrant hinge	1	
-86	24170-00		BRACKET ASSEMBLY - Control support	2	
-87	24172-00		SLEEVE - Control cable	4	

A - Used if Turbocharger is installed.  
 B - Used on PA-30 with serial numbers 30-2 to 30-1716 inclusive, 30-1718 to 30-1744 inclusive.  
 C - Used on PA-30 with serial numbers 30-1717, 30-1745 and up, and PA-39 with serial numbers 39-1 and up.  
 Y - Used on PA-30 airplanes only.  
 Z - Used on PA-39 airplanes only.

When ordering, always specify Part Number, Description and Serial Number of Aircraft



Figure and Index Number	Part Number	Code	NOMENCLATURE	No. Req.	SERIAL NUMBERS AFFECTED
37-88	30929-03	Y	CABLE ASSEMBLY - Left engine, mixture control cable, throttle control cable and propeller governor control cable, 145"	3	30-2 to 30-587 inclusive
	24894-03	YZ	CABLE ASSEMBLY - Left engine, mixture control cable, throttle control cable and propeller governor control cable, 149-5/8"	3	30-588 and up, 39-1 and up
-89	30929-07	Y	CABLE ASSEMBLY - Right engine, propeller governor control cable and throttle control cable, 149-5/8"	2	30-2 to 30-587 inclusive
	24894-03	YZ	CABLE ASSEMBLY - Right engine, propeller governor control cable and throttle control cable, 149-5/8"	2	30-588 and up, 39-1 and up
-90	30929-08	Y	CABLE ASSEMBLY - Right engine, mixture control cable, 141-1/8"	1	30-2 to 30-656 inclusive
	24894-03	YZ	CABLE ASSEMBLY - Right engine, mixture control cable, 149-5/8"	1	30-657 and up, 39-1 and up
-91	70371-03		FITTING	4	
-92	80012-11		BUSHING	2	
-93	26554-02	AB	PLATE - Trim, turbocharger control, black	1	
	26554-03	AB	PLATE - Trim, turbocharger control, white	1	
	26554-04	AB	PLATE - Trim, turbocharger control, beige	1	
-94	55447-02		RETAINER - Ball joint	6	

A - Used if Turbocharger is installed.  
 B - Used on PA-30 with serial numbers 30-1717, 30-1745 and up, and PA-39 with serial numbers 39-1 and up.  
 Y - Used on PA-30 airplanes only.  
 Z - Used on PA-39 airplanes only.

When ordering, always specify Part Number, Description and Serial Number of Aircraft

**1 J24**  
**INTENTIONALLY LEFT BLANK**



# PIPER PARTS CATALOG

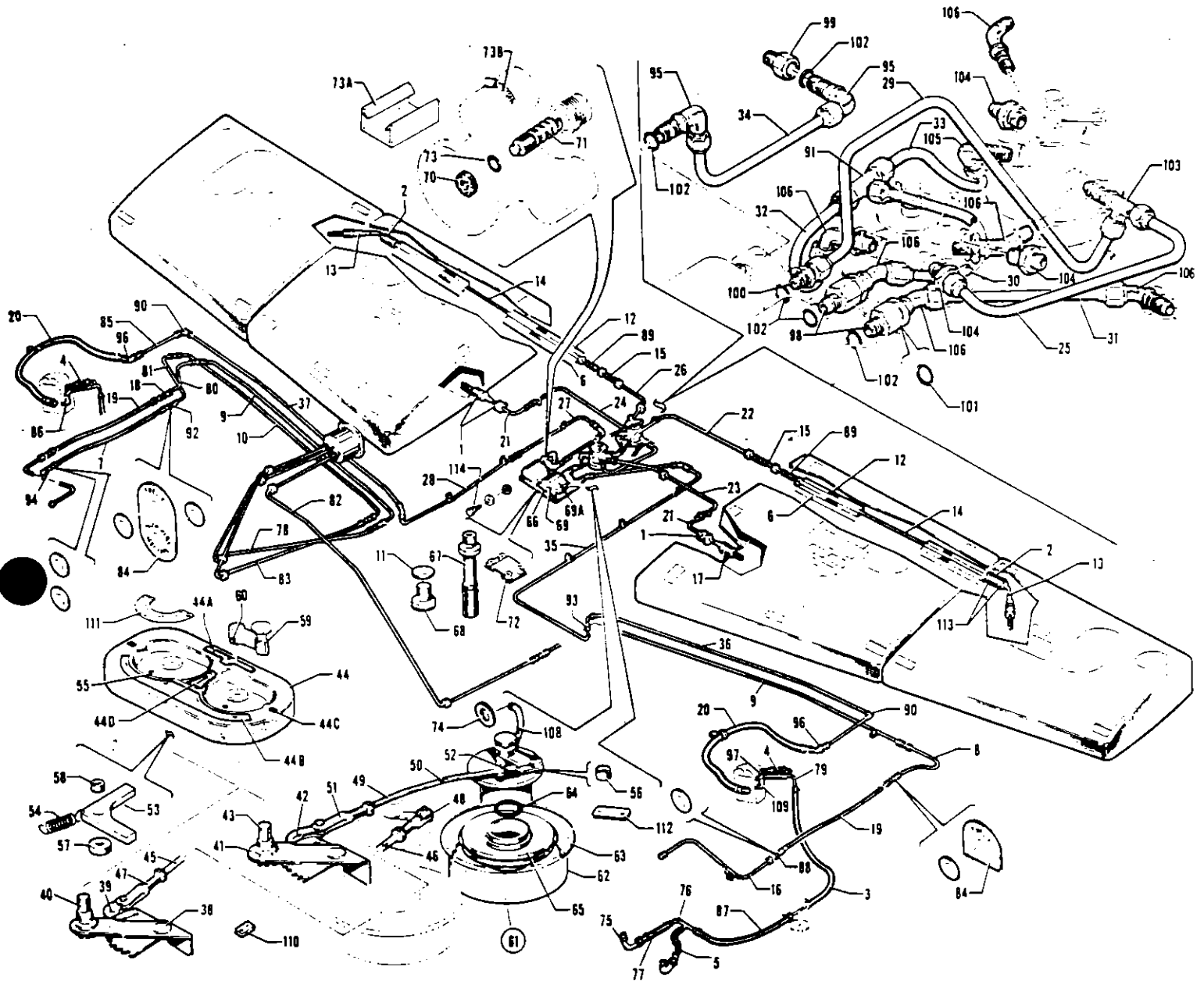

Figure 38. Fuel System Installation

SECTION VI  
Fuel System Group



FUEL SYSTEM INSTALLATION

Figure and Index Number	Part Number	Code	NOMENCLATURE	No. Req.	SERIAL NUMBERS AFFECTED
38-	23940		DRAWING - Fuel System Installation		
-1	16268-08		GROMMET - Caterpillar	2	
-2	16633-22		HOSE - Fuel cell	2	
-3	16633-36	Y	HOSE - Fuel pump drain	2	30-2 to 30-29 inclusive
	16633-47	YZ	HOSE - Fuel pump drain	2	30-30 and up. 39-1 and up
-4	16633-37	Y	HOSE - Fuel pump drain	4	30-2 to 30-197 inclusive
-5	61541-28		HOSE - Flexible fuel pump drain, right	2	
-6	17528-33		STRIP - Moleskin	4	
-7	17766-75		HOSE ASSEMBLY - Fuel line, LH	1	
-8	17984-05		LINE ASSEMBLY - Fuel pressure, 34" L, RH	1	
-9	17984-08		LINE ASSEMBLY - Fuel pressure, 51" L	2	
-10	17984-09		LINE ASSEMBLY - Fuel, 51" L, LH	1	
-11	25620-00	YZ	GROMMET - Fuel pump mounting	8	30-1150 to 30-1156 inclusive, 30-1158 and up. 39-1 and up
-12	22260-00		COVER ASSEMBLY - Fuel line	2	
-13	22267-00		STRAINER ASSEMBLY - Fuel tank finger	2	
-14	22281-03		LINE ASSEMBLY - Fuel	2	
-15	22503-00		LINE ASSEMBLY - Fuel	2	
-16	23195-10		LINE ASSEMBLY - Fuel	2	
-17	23230-00		SEAL - Fuel line	2	
-18	23319-00		UNION - Flared tube (Special)	4	
-19	23745-03		HOSE ASSEMBLY - Fuel	2	
-20	23745-07		HOSE ASSEMBLY - Fuel pressure	2	
-21	23924-00		STRAINER ASSEMBLY - Fuel tank finger, left	1	
	23924-01		STRAINER ASSEMBLY - Fuel tank finger, right	1	
-22	23925-00	A	LINE ASSEMBLY - Fuel (auxiliary)	1	
-23	23926-00		LINE ASSEMBLY - Fuel (main)	1	
-24	23927-00		LINE ASSEMBLY - Fuel (main)	1	
-25	23928-00		LINE ASSEMBLY - Fuel (cross over)	1	
-26	23929-00	A	LINE ASSEMBLY - Fuel (auxiliary)	1	
-27	23930-00		LINE ASSEMBLY - Fuel	1	
-28	23931-00		LINE ASSEMBLY - Fuel	1	
-29	23933-00		LINE ASSEMBLY - Fuel	1	
-30	23934-00		LINE ASSEMBLY - Fuel	1	
-31	23935-00		LINE ASSEMBLY - Fuel	1	
-32	23936-00		LINE ASSEMBLY - Fuel	1	
-33	23937-00		LINE ASSEMBLY - Fuel	1	
-34	23938-00		LINE ASSEMBLY - Fuel	1	
-35	23939-00		LINE ASSEMBLY - Fuel	1	
-36	23964-02		LINE ASSEMBLY - Fuel	1	
-37	23964-03		LINE ASSEMBLY - Fuel	1	
-38	24100-00		CONTROL ASSEMBLY - Fuel selector valve, left	1	
-39	24093-00		ARM - Fuel selector valve control	1	
-40	24150-00		CONTROL ASSEMBLY - Converter	1	
-41	24102-00		CONTROL ASSEMBLY - Fuel selector valve, right	1	
-42	24094-00		ARM - Fuel selector valve control	1	
-43	24150-00		CONTROL ASSEMBLY - Converter	1	

A - See Figure 40A if wing tip tanks are installed.  
Y - Used on PA-30 airplanes only.  
Z - Used on PA-39 airplanes only.

When ordering, always specify Part Number, Description and Serial Number of Aircraft

PIPER PARTS CATALOG

Figure and Index Number	Part Number	Code	NOMENCLATURE	No. Req.	SERIAL NUMBERS AFFECTED
38-44	24128-02		PLATE - Fuel valve protector, charcoal	1	
	24128-03	A	PLATE - Fuel valve protector, brown	1	
	24128-06		PLATE - Fuel valve protector, black	1	
	24128-14	C	PLATE - Fuel valve protector, red	1	
	24128-15	C	PLATE - Fuel valve protector, blue	1	
	24128-16	C	PLATE - Fuel valve protector, beige	1	
-44a	24958-00	YZ	* PLACARD - Fuel strainer access door	1	30-594 and up, 39-1 and up
-49b	24959-00	YZ	* PLACARD - Fuel tank selector	1	30-594 and up, 39-1 and up
-44c	24960-00	YZ	* PLACARD - Off position	1	30-594 and up, 39-1 and up
-44d	24964-00	YZ	* PLACARD - Crossfeed	1	30-594 and up, 39-1 and up
-45	24148-00		ROD ASSEMBLY - Fuel selector valve control, left	1	
-46	24089-00		* ROD - Fuel selector valve control	1	
-47	23091-00		* CLEVIS - Fuel selector valve control rod	1	
-48	24092-00		* CLEVIS - Fuel selector valve control rod	1	
-49	24147-00		ROD ASSEMBLY - Fuel selector valve control, right	1	
-50	24088-00		* ROD - Fuel selector valve control	1	
-51	24091-00		* CLEVIS - Fuel selector valve control rod	1	
-52	24092-00		* CLEVIS - Fuel selector valve control rod	1	
-53	24149-00	YZ	LINK - Fuel selector valve control guard	1	30-2 and up, 39-1 to 39-144
	27256-00	Z	LINK - Fuel selector valve control guard	1	39-145 and up
-54	24174-00		SPRING - Fuel valve control guard	1	
-55	400 675		BOLT - Clevis (AN23-13)	1	
-56	64076-10		BUSHING	2	
-57	64076-13	YZ	BUSHING	1	
-58	64076-12		BUSHING	1	
-59	25279-02	Y	HANDLE ASSEMBLY - Fuel selector valve control	2	30-2 to 30-826 inclusive
	25279-00	YZ	HANDLE ASSEMBLY - Fuel selector valve control	2	30-827 and up, 39-1 and up
-60	419 964		* SCREW - Set. selector valve handle (with special self-locking insert)	1	
-61	492 136		VALVE ASSEMBLY - Fuel selector, left (1H7-7)	1	
	492 137		VALVE ASSEMBLY - Fuel selector, right (1H7-8)	1	
-62	757 187		* KIT - Selector valve housing assembly (includes stainless steel housing, gasket, "O" ring and attaching hardware)	1	
-63	751 871		* * GASKET - Filter housing	1	
-64	755 919		* * "O" RING - Viton)	1	
-65	751 796		* FILTER ASSEMBLY - Fuel selector valve	1	
-66	23696-00	B	BRACKET ASSEMBLY - Pump mounting	1	
	23696-03	YZ	BRACKET ASSEMBLY - Pump mounting	1	30-1150 to 30-1156 inclusive, 30-1158 and up, 39-1 and up
-67	90797-80		SLEEVE	2	
-68	401 918	B	BOLT - Pump mounting (AN74A-3)	8	
	401 922	YZ	BOLT - Pump mounting (AN74A-7)	8	30-1150 to 30-1156 inclusive, 30-1158 and up, 39-1 and up

A - Used on PA-30 with serial numbers 30-2 to 30-1716 inclusive, 30-1718 to 30-1744 inclusive.  
 B - Used on PA-30 with serial numbers 30-2 to 30-1149 inclusive, and 30-1157.  
 C - Used on PA-30 with serial numbers 30-1717, 30-1745 and up, and PA-39 with serial numbers 39-1 and up.  
 Y - Used on PA-30 airplanes only.  
 Z - Used on PA-39 airplanes only.

When ordering, always specify Part Number, Description and Serial Number of Aircraft

PIPER PARTS CATALOG

Figure and Index Number	Part Number	Code	NOMENCLATURE	No. Req.	SERIAL NUMBERS AFFECTED
38-69	763 819		FUEL PUMP REPLACEMENT KIT - Left and right	2	
-69a	753 651	AF	* MOTOR - Fuel pump (8800-12)	1	
	753 715	BCF	* MOTOR - Fuel pump (8800-12B)	1	
	761 677	G	* MOTOR - Fuel pump (8850-5A)	1	
-70	756 155		* SEAL - Shaft	1	
-71	756 156	AB	* SPRING - Valve	1	
	757 717	CG	* SPRING - Valve	1	
-72	753 457	D	* BASE - Fuel pump motor	1	
	753 458	E	* BASE - Fuel pump motor	1	
-73	752 741	AB	* PACKING - "O" Ring (MS29513-6)	1	
-73a	33963-02	G	* BRACKET ASSEMBLY - Fuel pump	2	
-73b	454 818	G	* CLAMP - (SAE TYF-32)	1	
-74	16268-06		GROMMET - Caterpillar	2	
-75	24995-00		VALVE ASSEMBLY - Automatic fuel drain	4	
-76	24382-00		TUBE ASSEMBLY - Drain connector	2	
-77	61541-27		HOSE - Flexible, fuel pump drain, left	2	
-78	17984-14		LINE ASSEMBLY - Fuel pressure	1	
-79	24037-00	Y	TUBE ASSEMBLY - Drain connector	2	30-2 to 30-197 inclusive
-80	24051-02		LINE ASSEMBLY - Fuel	1	
-81	24051-03		LINE ASSEMBLY - Fuel	1	
-82	24051-04		LINE ASSEMBLY - Fuel	1	
-83	24051-05		LINE ASSEMBLY - Fuel	1	
-84	24053-00		PLACARD - Fuel pressure	1	
	24053-02		PLACARD - Fuel flow meter vent	1	
-85	24059-00		LINE ASSEMBLY - Fuel	2	
-86	24060-00		VALVE ASSEMBLY - Check	2	
-87	82371-95		HOSE - Flexible	2	
-88	491 048		UNION - (AN815-2D)	3	
-89	491 051		UNION - (AN815-5D)	7	
-90	458 884		ELBOW - (AN821-5D)	2	
-91	488 321		TEE - (AN824-5D)	1	
-92	491 064		UNION - (AN832-2)	1	
-93	491 058		UNION - (AN832-2D)	3	
-94	458 933		ELBOW - (AN833-2)	1	
-95	458 901		ELBOW - (AN833-6D)	2	
-96	458 939		ELBOW - (AN837-5)	2	
-97	458 940	Y	ELBOW - (AN844-4D)	2	30-2 to 30-197 inclusive
-98	453 681		REDUCER BUSHING - (AN893-7D)	2	
-99	453 672		EXPANDER BUSHING - (AN894D6-5)	1	
-100	484 352		REDUCER - (AN919-7D)	1	
-101	462 059		"O" RING - (MS29512-5)	2	
-102	462 060		"O" RING - (MS29512-6)	5	

- A - Used with Fuel Pump 24058-00 and 24058-01.
- B - Used with Fuel Pump 24058-02, 24058-03, 24058-04 and 24058-05.
- C - Used with Fuel Pump 24058-06 and 24058-07.
- D - Used with Fuel Pump Motor #8800-12.
- E - Used with Fuel Pump Motor #8800-12B.
- F - Not available. Order Fuel Pump Replacement Kit 763 819.
- G - Used with Fuel Pump C8100G only.
- Y - Used on PA-30 airplanes only.

When ordering, always specify Part Number, Description and Serial Number of Aircraft



Figure and Index Number	Part Number	Code	NOMENCLATURE	No. Req.	SERIAL NUMBERS AFFECTED
38-103	488 481		TEE - (AN804-5D)	1	
-104	491 051		UNION - (AN815-5D)	3	
-105	458 878		ELBOW - (AN833-5D)	2	
-106	458 911		ELBOW - (AN837-5D)	7	
-107	462 059		GASKET - (MS29512-5)	8	
-108	22369-14		TUBE - Plastic (4" L)	2	
	22369-15		TUBE - Plastic (7-1/2" L)	2	
-109	458 873		ELBOW - (MS20822-5-4)	2	
-110	24268-00		STOP - Fuel selector control arm	1	
-111	25265-00	YZ	PLATE - Fuel selector valve control lock	2	30-827 and up, 39-1 and up
-112	81262-105	YZ	LINK - Fuel selector valve	1	30-827 and up, 39-1 and up
-113	554 888		CLAMP - (SAE TY F-6)	4	
-114	401 266		BOLT - (AN3-5A) Bracket attachment	4	
	19513-59		WASHER - Bracket attachment	8	
	434 127		GROMMET - (AN931-3-10) Bracket attachment	4	

Y - Used on PA-30 airplanes only.  
Z - Used on PA-39 airplanes only.

When ordering, always specify Part Number, Description and Serial Number of Aircraft

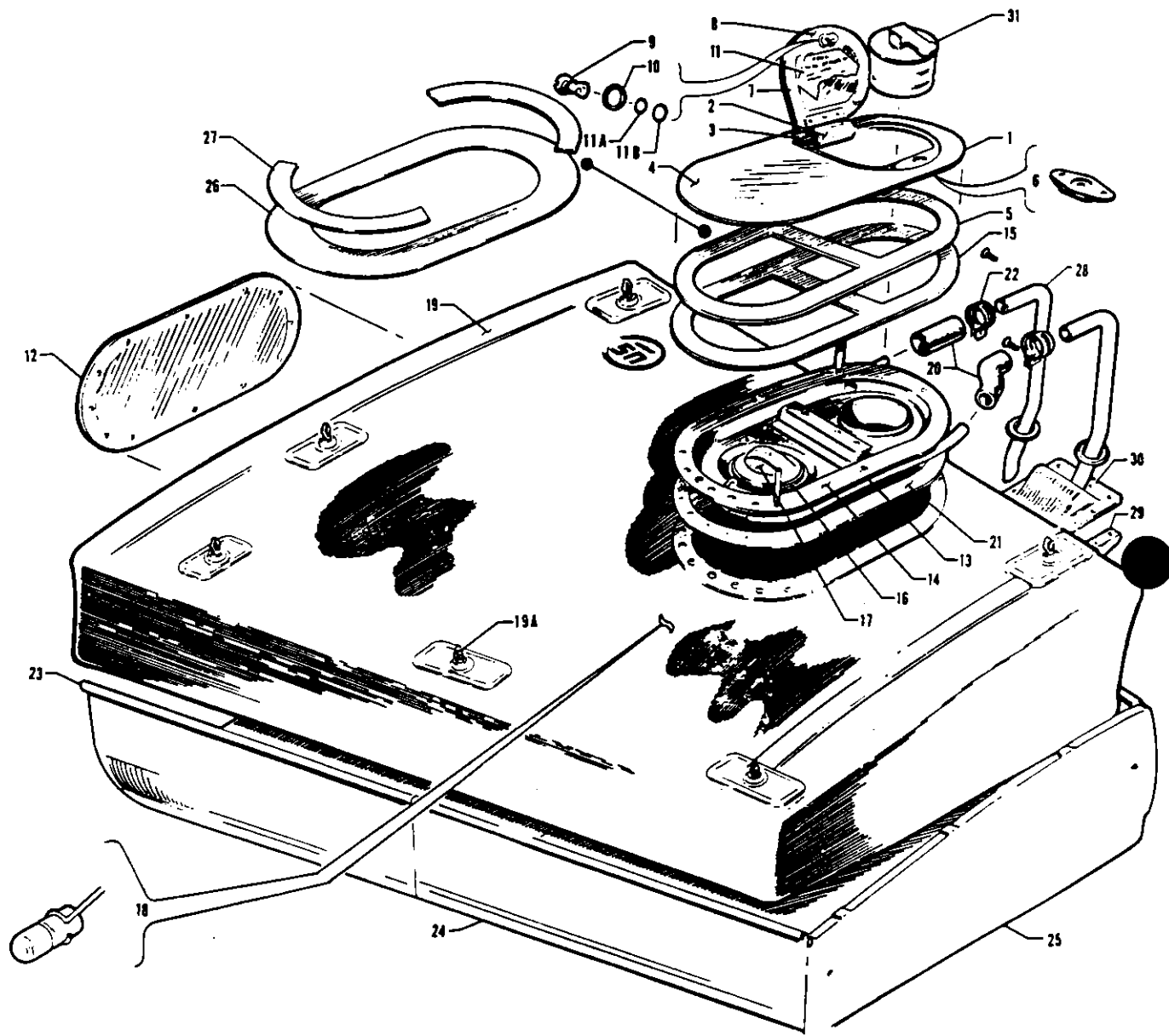

Figure 39. Fuel Cell Installation - Inboard



Figure and Index Number	Part Number	Code	NOMENCLATURE	No. Req.	SERIAL NUMBERS AFFECTED
39-	23030 22948		DRAWING - Fuel Cell Installation, Inboard DRAWING - Compartment Installation, Fuel Inboard		
-1	20329-10 26805-06 26249-02 26249-08	BY Z BY Z	PLATE ASSEMBLY - Fuel cell access hole cover, left PLATE ASSEMBLY - Fuel cell access hole cover, left PLATE ASSEMBLY - Fuel cell access hole cover, right PLATE ASSEMBLY - Fuel cell access hole cover, right	1 1 1 1	
-2	20325-00		HINGE ASSEMBLY - Access hole cover	1	
-3	20326-00		BRACKET - Access hole cover	1	
-4	20328-02		PLATE - Fuel cell access hole cover	1	
-5	20366-00	Y	GASKET - Fuel cell cover plate, upper	1	
-6	484 342		RECEPTACLE	1	
-7	21817-10	Y	COVER ASSEMBLY - Fuel cell access hole (with ring type gasket) left	1	
	25656-02	Y	COVER ASSEMBLY - Fuel cell access hole (with disc type gasket) left	1	
	25656-09	AZ	COVER ASSEMBLY - Fuel cell access hole, left	1	
	26248-02	Y	COVER ASSEMBLY - Fuel cell access hole, right	1	
	26248-07	AZ	COVER ASSEMBLY - Fuel cell access hole, right	1	
-8	20327-03 25655-00		GASKET - Cover (ring type) GASKET - Cover (disc type)	1 1	
-9	487 590		STUD - Wing (2600-5W) (with ring type cover gasket)	1	
	487 692		STUD - Wing (2600-8W) (with disc type cover gasket)	1	
	26246-00		STUD - Slotted head (with disc type cover gasket)	1	
-10	494 060		LOCK WASHER	1	
-11	25654-02 27099-00	Y AZ	PLATE - Gasket retainer PLATE - Gasket retainer	1 1	
-11a	484 707		"O" RING - (AN6227B-3)	1	
-11b	484 708		"O" RING - (AN6227B-6)	1	
-12	20333-00		PLATE - Access hole cover	2	
-13	20899-02 20899-03		PLATE ASSEMBLY - Fuel cell, LH PLATE ASSEMBLY - Fuel cell, RH	1 1	
-14	23426-02 23426-03		PLATE ASSEMBLY - Fuel cell access hole, LH PLATE ASSEMBLY - Fuel cell access hole, RH	1 1	
-15	20366-02		GASKET - Fuel cell cover plate, lower	1	
-16	13002-00		GASKET - Fuel tank gauge	1	
-17	20966-00		GAUGE ASSEMBLY - Fuel	1	
-18	751 767		FLOAT - Fuel gauge	1	
-19	23799-00 23799-01		CELL ASSEMBLY - Fuel, LH CELL ASSEMBLY - Fuel, RH	1 1	
-19a	752 016		HANGER - Fuel cell (295055)	9	
-20	82371-47		HOSE - Flexible	4	
-21	462 014		GASKET - Fuel cell	2	
-22	454 922		CLAMP	4	

A - Used on PA-30 with counter-rotating right engine.  
 B - If ordering for PA-30 with counter-rotating right engine, also order and install SK-2164 placard over existing octane rating.  
 Y - Used on PA-30 airplanes only.  
 Z - Used on PA-39 airplanes only.

When ordering, always specify Part Number, Description and Serial Number of Aircraft



Figure and Index Number	Part Number	Code	NOMENCLATURE	No. Req.	SERIAL NUMBERS AFFECTED
39-23	22902-00		LINER - Fuel cell, inboard, LH	1	
	22902-01		LINER - Fuel cell, inboard, RH	1	
-24	20286-04		LINER - Fuel cell, outboard, LH	1	
	20286-05		LINER - Fuel cell, outboard, RH	1	
-25	20287-00		LINER ASSEMBLY - Fuel cell, outboard, LH	1	
	20287-01		LINER ASSEMBLY - Fuel cell, outboard, RH	1	
-26	20330-00	Y	PLATE - Access hole reinforcement, left	1	
	26760-00	Z	PLATE - Access hole reinforcement, left	1	
	20330-02	Y	PLATE - Access hole reinforcement, right	1	
	26760-01	Z	PLATE - Access hole reinforcement, right	1	
-27	20332-00	Y	SPACER - Reinforcement plate	2	
-28	21885-03		TUBE - Fuel cell drain	2	
-29	23478-00		PLATE - Fuel vent, LH	1	
	23478-01		PLATE - Fuel vent, RH	1	
-30	23464-00		VENT ASSEMBLY - Fuel cell, LH	1	
	23464-01		VENT ASSEMBLY - Fuel cell, RH	1	
-31	27221-00		CAP - Fuel cell	2	

Y - Used on PA-30 airplanes only.  
Z - Used on PA-39 airplanes only.

When ordering, always specify Part Number, Description and Serial Number of Aircraft



PIPER PARTS CATALOG

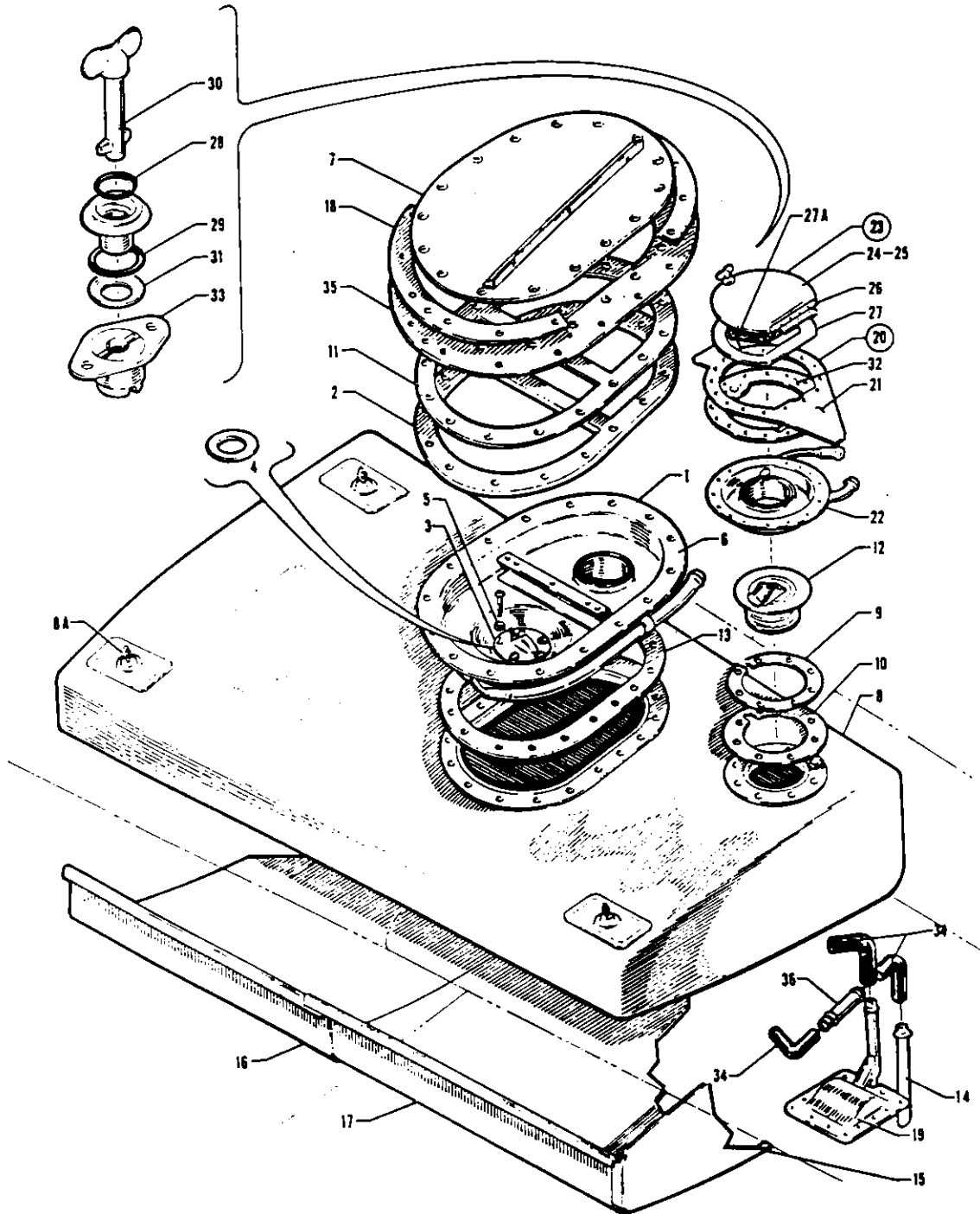

Figure 40. Fuel Cell Installation - Outboard

SECTION VI  
Fuel System Group



FUEL CELL INSTALLATION - OUTBOARD

Figure and Index Number	Part Number	Code	NOMENCLATURE	No. Req.	SERIAL NUMBERS AFFECTED
40-	23579 23538		DRAWING - Cell Installation, Fuel Outboard DRAWING - Compartment Installation, Fuel Outboard		
-1	22451-04 22451-05		PLATE ASSEMBLY - Fuel cell access hole, LH PLATE ASSEMBLY - Fuel cell access hole, RH	1 1	
-2	20366-02		GASKET - Fuel cell cover plate, lower	1	
-3	20966-02		GAUGE ASSEMBLY - Fuel	1	
-4	462 021		GASKET - Fuel tank gauge	1	
-5	494 063		WASHER - Weather seal	5	
-6	23527-00 23527-01		PLATE ASSEMBLY - Fuel cell access hole, LH PLATE ASSEMBLY - Fuel cell access hole, RH	1 1	
-7	23553-00 23553-04 23553-01 23553-05	Y Z Y Z	PLATE ASSEMBLY - Fuel cell access hole cover, LH PLATE ASSEMBLY - Fuel cell access hole cover, LH PLATE ASSEMBLY - Fuel cell access hole cover, RH PLATE ASSEMBLY - Fuel cell access hole cover, RH	1 1 1 1	
-8	22037-02 22037-03		CELL ASSEMBLY - Fuel, LH CELL ASSEMBLY - Fuel, RH	1 1	
-8a	752 016		HANGER - Fuel cell (295055)	3	
-9	23542-00		PLATE - Fuel cell attachment	2	
-10	22846-00		GASKET - Fuel cell	2	
-11	20366-00	Y	GASKET - Fuel cell cover plate, upper	2	
-12	27221-00		CAP - Fuel cell	2	
-13	462 014		GASKET - Fuel cell	2	
-14	23554-00 23554-02	Y YZ	TUBE - Fuel cell drain TUBE - Fuel cell drain	1 1	30-2 to 30-114 inclusive 30-115 and up, 39-1 and up
-15	22271-00 22271-01		LINER - Fuel cell outboard, LH LINER - Fuel cell outboard, RH	1 1	
-16	22274-02 22274-03		LINER - Fuel cell outboard, LH LINER - Fuel cell outboard, RH	1 1	
-17	22274-04 22274-05		LINER - Fuel cell outboard, LH LINER - Fuel cell outboard, RH	1 1	
-18	20332-00	Y	SPACER - Reinforcement plate	2	
-19	24041-00 24041-04 24041-01 24041-05	Y YZ Y YZ	VENT ASSEMBLY - Fuel cell outboard, LH VENT ASSEMBLY - Fuel cell outboard, LH VENT ASSEMBLY - Fuel cell outboard, RH VENT ASSEMBLY - Fuel cell outboard, RH	1 1 1 1	30-2 to 30-114 inclusive 30-115 and up, 39-1 and up 30-2 to 30-114 inclusive 30-115 and up, 39-1 and up
-20	23529-00 23529-02 23529-04 23529-01 23529-03 23529-05	AY AY Z AY AY Z	NECK ASSEMBLY - Fuel cell filter, outboard, LH NECK ASSEMBLY - Fuel cell filter, outboard, LH NECK ASSEMBLY - Fuel cell filter, outboard, LH NECK ASSEMBLY - Fuel cell filter, outboard, RH NECK ASSEMBLY - Fuel cell filter, outboard, RH NECK ASSEMBLY - Fuel cell filter, outboard, RH	1 1 1 1 1 1	30-2 to 30-114 inclusive 30-115 and up 39-1 and up 30-2 to 30-114 inclusive 30-115 and up 39-1 and up
-21	23659-00 23659-01		SPACER - Reinforcement plate, LH SPACER - Reinforcement plate, RH	1 1	
-22	23536-00 23536-01 23536-01 23536-00	Y YZ Y YZ	PLATE ASSEMBLY - Fuel cell filler neck, LH PLATE ASSEMBLY - Fuel cell filler neck, LH PLATE ASSEMBLY - Fuel cell filler neck, RH PLATE ASSEMBLY - Fuel cell filler neck, RH	1 1 1 1	30-2 to 30-114 inclusive 30-115 and up, 39-1 and up 30-2 to 30-114 inclusive 30-115 and up, 39-1 and up

A - If ordering for PA-30 with counter-rotating right engine, also order and install SK-2164 placard over existing octane rating.  
Y - Used on PA-30 airplanes only.  
Z - Used on PA-39 airplanes only.

When ordering, always specify Part Number, Description and Serial Number of Aircraft

PIPER PARTS CATALOG

Figure and Index Number	Part Number	Code	NOMENCLATURE	No. Req.	SERIAL NUMBERS AFFECTED
40-23	19156-14	Y	* PLATE ASSEMBLY - Fuel cell filler neck cover, LH	1	
	25900-04	C,Z	* PLATE ASSEMBLY - Fuel cell filler neck cover, LH	1	
	19156-15	Y	* PLATE ASSEMBLY - Fuel cell filler neck cover, RH	1	
	25900-05	C,Z	* PLATE ASSEMBLY - Fuel cell filler neck cover, RH	1	
-24	22982-02	Y	** PLATE ASSEMBLY - Fuel cell filler neck cover (complete) (with ring type gasket)	1	
	31196-03	Y	** PLATE ASSEMBLY - Fuel cell filler neck cover (complete) (with disc type gasket)	1	
	31196-05	C,Z	** PLATE ASSEMBLY - Fuel cell filler neck cover (complete)	1	
-25	19047-04	A	*** PLATE ASSEMBLY - Fuel cell filler neck cover	1	
	19047-06	B	*** PLATE ASSEMBLY - Fuel cell filler neck cover	1	
-26	189 302		*** HINGE - Fuel cell filler neck cover (6" L)	1	
-27	19051-00	A	*** GASKET - Fuel filler cover plate (ring type)	1	
	31190-00	B	*** GASKET - Fuel filler cover plate (disc type)	1	
-27a	25654-06	B,Y	*** PLATE - Gasket retainer	1	
	27100-00	C,Z	*** PLATE - Gasket retainer	1	
-28	484 707		*** PACKING - "O" Ring (AN6227B-3)	1	
-29	484 708		*** PACKING - "O" Ring (AN6227B-6)	1	
-30	487 590	A	*** STUD - (2600-5W)	1	
	487 657	B	*** STUD - (2600-6W)	1	
-31	494 060		*** LOCK WASHER - (2600-LW)	1	
-32	16090-00		** PLATE ASSEMBLY - Fuel cell filler hole reinforcement, LH	1	
	16090-01		** PLATE ASSEMBLY - Fuel cell filler hole reinforcement, RH	1	
-33	484 342		*** RECEPTACLE - (212-12D)	1	
-34	455 149		CONNECTION - Hose	3	
-35	20330-00	Y	PLATE - Access hole reinforcement, LH	1	
	26760-00	Z	PLATE - Access hole reinforcement, LH	1	
	20330-02	Y	PLATE - Access hole reinforcement, RH	1	
	26760-01	Z	PLATE - Access hole reinforcement, RH	1	
-36	24424-00	Y,Z	TUBE - Fuel cell drain	1	30-115 and up, 39-1 and up

A - Used with cover assembly 22982-02 only.  
 B - Used with cover assembly 31196-03 only.  
 C - Used on PA-30 with counter-rotating right engine.  
 Y - Used on PA-30 airplanes only.  
 Z - Used on PA-39 airplanes only.

When ordering, always specify Part Number, Description and Serial Number of Aircraft

**1 K12**  
**INTENTIONALLY LEFT BLANK**

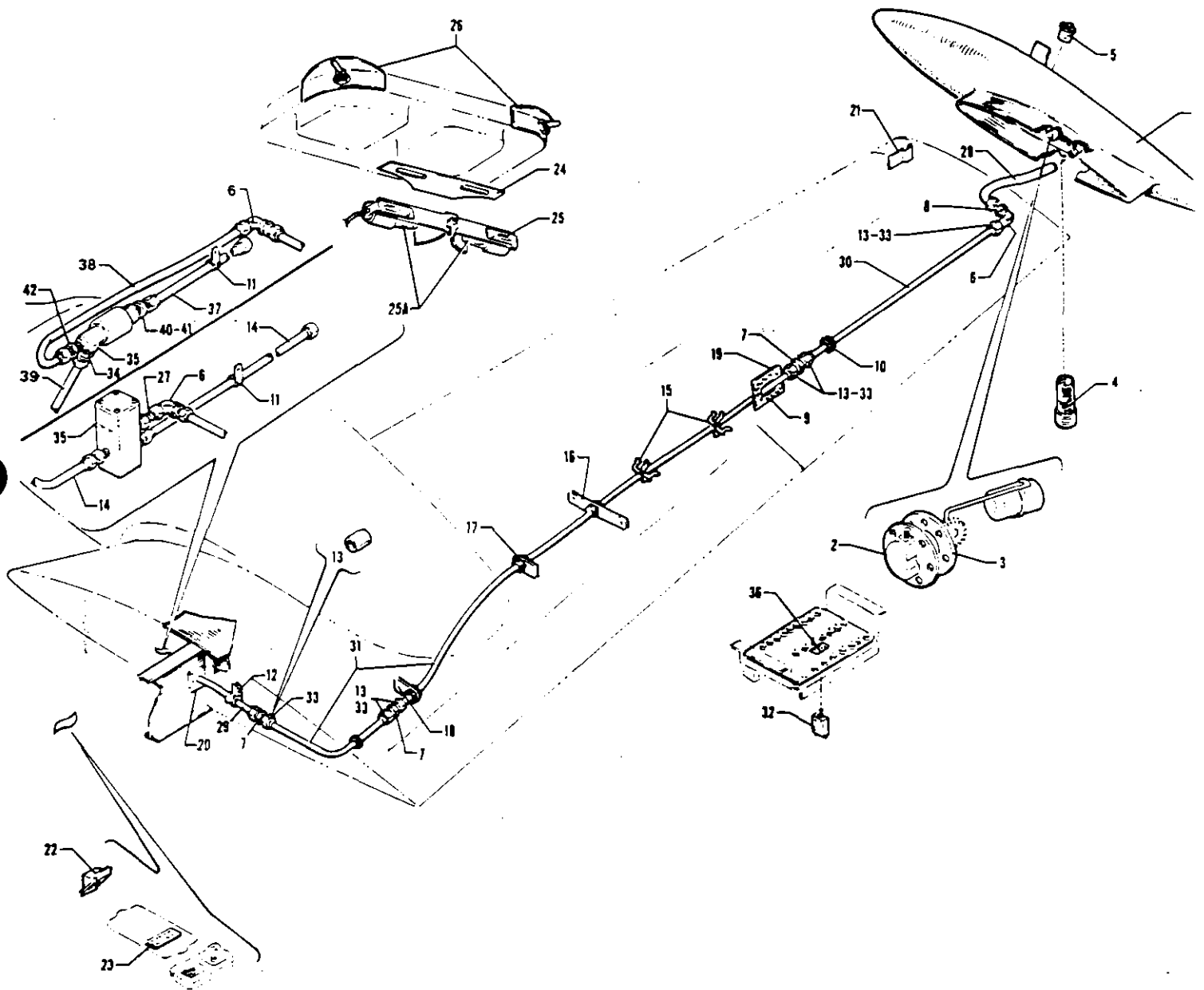

Figure 40A. Wing Tip Tank Installation



Figure and Index Number	Part Number	Code	NOMENCLATURE	No. Req.	SERIAL NUMBERS AFFECTED
40A	25348 26691 27019	A Y YZ	DRAWING - Wing Tip Fuel Tank Installation DRAWING - Wing Tip Fuel Tank Installation DRAWING - Wing Tip Fuel Tank Installation		30-1717, 30-1745 to 30-1950 30-1951 and up, 39-1 and up
-1	753 070 753 069		TANK ASSEMBLY - Wing tip, left TANK ASSEMBLY - Wing tip, right	1 1	
-2	751 884		FUEL GAUGE ASSEMBLY - Tip tank	1	
-3	751 885		GASKET - Fuel gauge	1	
-4	754 543		QUICK DRAIN ASSEMBLY	1	
-5	757 204		PLUG - Tip tank	1	
-6	458 901		ELBOW - 90° (AN833-6D)	4	
-7	491 052		UNION - (AN815-6D)	6	
-8	477 620		NUT - (AN924-6D)	4	
-9			GROMMET - (G51H-A 6")	2	
-10			GROMMET - (500-6)	8	
-11			CLIP - (AN742-5D)	2	
-12			CLIP - (AN742-6D)	2	
-13	486 899		SLEEVE - (AN819-6D)	12	
-14	23925-00 23929-00	C C	LINE ASSEMBLY - Fuel, left LINE ASSEMBLY - Fuel, right	2 2	
-15	756 228		SPIDER - Fuel line support	4	
-16	756 229		TAB - Fuel line support	2	
-17	756 230		TAB - Fuel line support	2	
-18	756 231		TAB - Fuel line support	2	
-19	754 540		DOUBLER - Rear spar, aft	2	
-20	754 541		DOUBLER - Main spar, aft	2	
-21	756 224		STIFFENER - Landing light support	2	
-22	753 925		COVER - Floor shield	2	
-23	755 897		PLACARD	1	
-24	755 898		PLACARD PLATE - Selector switch	1	
-25	752 346		LIGHT ASSEMBLY - Fuel valve protector plate	1	
-25a	753 472		BULB - Fuel valve protector plate	2	
-26	756 225		SWITCH ASSEMBLY - Fuel selector, left	1	
	756 226		SWITCH ASSEMBLY - Fuel selector, right	1	
-27	753 926	C	COUPLER ASSEMBLY - Fuel valve	2	
-28	752 344		HOSE ASSEMBLY - Fuel	2	
-29	752 345		LINE ASSEMBLY - Fuel	2	
-30	753 071		TUBING - Fuel line (70" length)	2	
-31	753 072		TUBING - Fuel line (12' length)	2	
-32	454 656		CIRCUIT BREAKER - (5 Amp)	1	
-33	477 614		NUT - (AN818-6D)	12	
-34	458 896	B	ELBOW - (AN822-5D) Left	1	
	476 661	B	NIPPLE - (AN816-5D) Right	1	

A - Used on PA-30 with serial numbers 30-2 to 30-1716 inclusive, 30-1718 to 30-1744 inclusive.  
 B - Used if Model #3406-00-11 Fuel Valve Assembly is installed.  
 C - Used if Model #55031 Fuel Valve Assembly is installed.  
 Y - Used on PA-30 airplanes only.  
 Z - Used on PA-39 airplanes only.

When ordering, always specify Part Number, Description and Serial Number of Aircraft



Figure and Index Number	Part Number	Code	NOMENCLATURE	No. Req.	SERIAL NUMBERS AFFECTED
40A-35	756 227	BY	VALVE ASSEMBLY - Fuel (#55031)	2	30-2 to 30-1985 inclusive 30-1986 and up, 39-1 and up
	756 519	YZ	VALVE ASSEMBLY - Fuel (#3406-00-11)	2	
-36	25336-00		PLACARD - Circuit protector panel, "AND TIP TANK"	1	
-37	752 374	A	LINE ASSEMBLY - Fuel	2	
-38	761 151	A	LINE ASSEMBLY - Fuel	2	
-39	761 152	A	LINE ASSEMBLY - Valve assembly to fuel selector, left	1	
	761 153	A	LINE ASSEMBLY - Valve assembly to fuel selector, right	1	
-40	484 350	A	REDUCER - (AN919-3D)	2	
-41	462 058	A	"O" RING - (MS29512-04)	2	
-42	476 700	A	NIPPLE - (AN816-6-2D)	2	

A - Used if Model #3406-00-11 Fuel Valve Assembly is installed.  
 B - Order Valve Assembly, Part No. 756 519 if Fuel Valve Replacement Kit 760 341, which incorporates a Model #3406-00-11 Valve, has been installed.  
 Y - Used on PA-30 airplanes only.  
 Z - Used on PA-39 airplanes only.

When ordering, always specify Part Number, Description and Serial Number of Aircraft

PIPER PARTS CATALOG

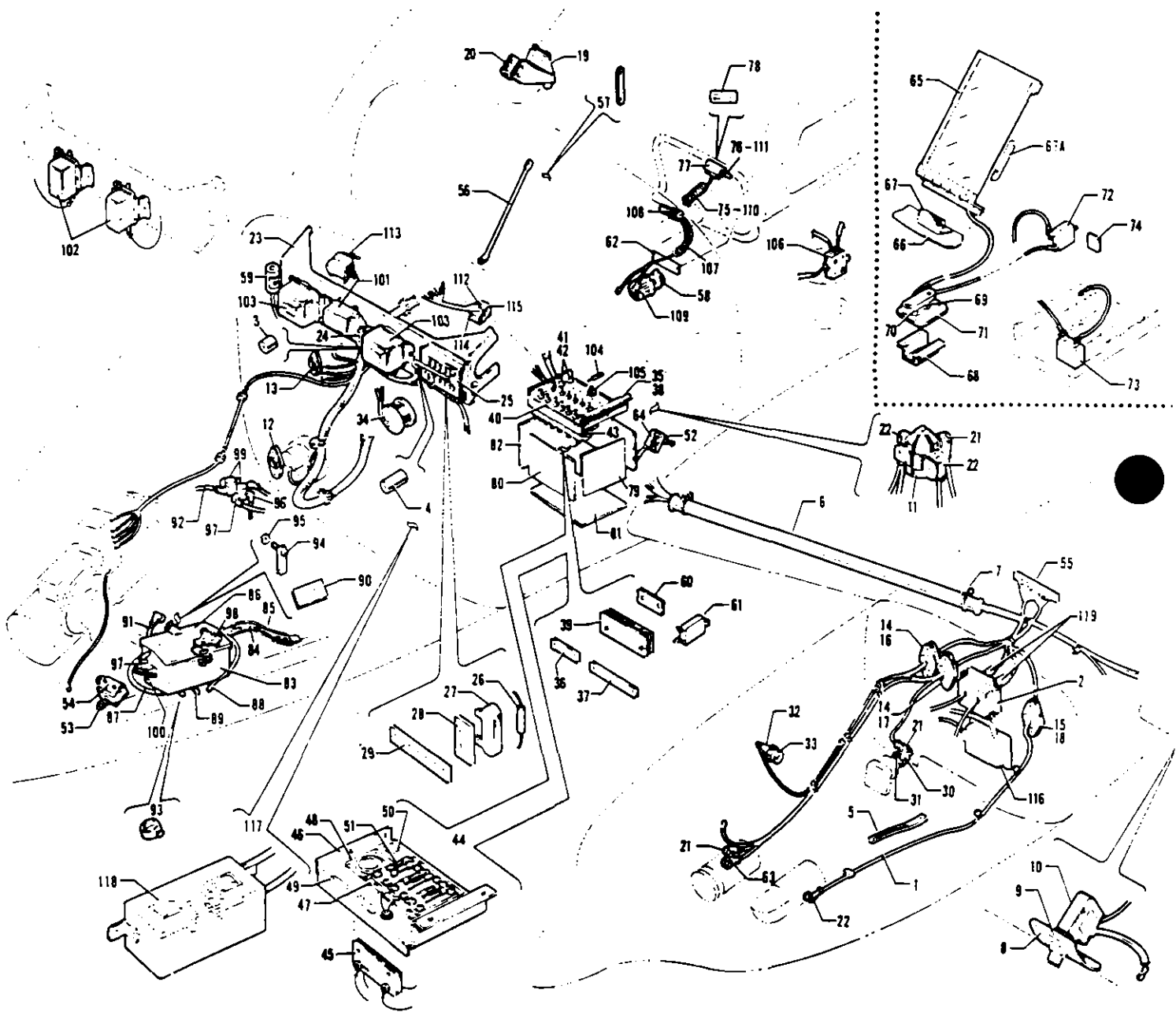

Figure 41. Electrical System - Forward





Figure and Index Number	Part Number	Code	NOMENCLATURE	No. Req.	SERIAL NUMBERS AFFECTED
41-	23700	B	DRAWING - Electrical System Installation		
	26651	D	DRAWING - Electrical System Installation		
	23730	B	DRAWING - Dual Generators Installation		
	25221	B	DRAWING - Heated Windshield		
	26711	D	DRAWING - Heated Windshield		
	24889	B	DRAWING - Electric Stabilator Trim Installation		
	26754	D	DRAWING - Electric Stabilator Trim Installation		
	25485	A	DRAWING - Battery Box Installation		
	26664	D	DRAWING - Battery Box Installation		
	25973	C	DRAWING - Map Light Installation		
-1	14226-34		WIRE ASSEMBLY - Starter, left engine	1	
	14226-35		WIRE ASSEMBLY - Starter, right engine	1	
-2	14311-37		BOX ASSEMBLY - Magneto filter, left engine	1	
	14311-38		BOX ASSEMBLY - Magneto filter, right engine	1	
-3	14976-101		BUSHING	1	
-4	14976-93		BUSHING	1	
-5	17604-21		CABLE ASSEMBLY - Ground (7-1/8" L)	2	
-6	17752-03		CONDUIT - Wire harness	2	
-7	18329-02		BOLT - "U"	4	
-8	19807-00		PLATE - Lift detector mounting	1	
-9	450 741		DECAL - Lift detector	1	
-10	450 742		LIFT DETECTOR	1	
-11	21061-00	B	SWITCH - Magnetic, landing gear	2	
	487 152	D	SOLENOID - Landing gear (26898-03)	2	
-12	22103-02		PLATE - Firewall seal grommet	2	
	22105-02		GASKET - Firewall seal	1	
	22104-08		GROMMET - Firewall seal, rubber	2	
-13	22103-02	D	PLATE - Firewall seal grommet	2	
	22105-07	D	GASKET - Firewall seal	1	
	22104-06	D	GROMMET - Firewall seal, rubber	2	
-14	22103-02		PLATE - Firewall seal grommet, left engine	4	
	22104-07		GROMMET - Firewall seal, rubber, left engine	4	
	22105-05		GASKET - Firewall seal, left engine	2	
-15	22103-02		PLATE - Firewall seal, grommet, left engine	2	
	22104-06		GROMMET - Firewall seal, rubber, left engine	2	
	22105-07		GASKET - Firewall seal, left engine	1	
-16	22103-02		PLATE - Firewall seal grommet, right engine	2	
	22104-03	B	GROMMET - Firewall seal, rubber, right engine	2	
	22104-07	D	GROMMET - Firewall seal, rubber, right engine	2	
	22105-03	B	GASKET - Firewall seal, right engine	1	
	22105-05	D	GASKET - Firewall seal, right engine	1	
			A - Used on PA-30 with serial numbers 30-853, 30-902 to 30-1716 inclusive, 30-1718 to 30-1744 inclusive.		
			B - Used on PA-30 with serial numbers 30-2 to 30-1716 inclusive, 30-1718 to 30-1744 inclusive.		
			C - Used on PA-30 with serial numbers 30-1511 to 30-1716 inclusive, 30-1718 to 30-1744 inclusive.		
			D - Used on PA-30 with serial numbers 30-1717, 30-1745 and up, and PA-39 with serial numbers 39-1 and up.		

When ordering, always specify Part Number, Description and Serial Number of Aircraft

PIPER PARTS CATALOG

Figure and Index Number	Part Number	Code	NOMENCLATURE	No. Req.	SERIAL NUMBERS AFFECTED
41-17	22103-02		PLATE - Firewall seal grommet, right engine	2	
	22104-02	A	GROMMET - Firewall seal, rubber, right engine	2	
	22104-07	B	GROMMET - Firewall seal, rubber, right engine	2	
	22105-02	A	GASKET - Firewall seal, right engine	1	
	22105-05	B	GASKET - Firewall seal, right engine	1	
-18	22103-02		PLATE - Firewall seal grommet, right engine	2	
	22104-06		GROMMET - Firewall seal, rubber, right engine	2	
	22105-07		GASKET - Firewall seal, right engine	1	
-19	22197-00		BRACKET ASSEMBLY - Compass card holder	1	
-20	22198-00		BRACKET - Compass mounting, left	1	
	22198-01		BRACKET - Compass mounting, right	1	
-21	23969-02		NIPPLE - Electrical terminal	7	
-22	23969-04		NIPPLE - Electrical terminal	4	
-23	25758-04	A,C	SHELF ASSEMBLY - Electrical accessory	1	
	27261-00	Z	SHELF ASSEMBLY - Electrical accessory	1	39-146 and up
-24	19286-00	A	CAPACITOR ASSEMBLY	1	
-25	23605-00		BOX ASSEMBLY - Flasher	1	
-26	484 380		* RESISTOR - (BW-2)	3	
-27	460 901		* FLASHER - (617)	2	
-28	452 897		* TERMINAL BLOCK - (4753)	2	
-29	487 654		* TERMINAL STRIP - (17-5)	2	
-30	462 046	D	BULB - Engine oil temperature (A. C. Spark Plug)	2	
	486 425	E	BULB - Engine oil temperature (Rochester gauge)	2	
-31	462 012		GASKET - Engine oil temperature gauge	2	
-32	462 044	D	GAUGE - Engine cylinder head temperature (A. C. Spark Plug)	2	
	763 526	E	GAUGE - Engine cylinder head temperature (Rochester gauge)	2	
-33	462 018		GASKET - Engine cylinder temperature gauge	2	
-34	465 162	Y	HORN ASSEMBLY - Landing gear warning	1	30-2 to 30-1731 inclusive
	565 273	Y	HORN ASSEMBLY - Landing gear warning	1	30-1732 to 30-1805 inclusive
	565 325	Y,Z	HORN ASSEMBLY - Landing gear warning	1	30-1806 and up, 39-1 and up
-35	24140-00	A	PANEL ASSEMBLY - Circuit protector	1	
-36	22856-02	A	* BAR - Bus (1-1/16 L.)	8	
-37	22856-03	A	* BAR - Bus (1-13/16 L.)	1	
-38	23606-00	A	* BRACKET - Circuit protector	1	
-39	23844-00	A	* SHUNT ASSEMBLY - (486 615)	1	
-40	24078-03	A	* PLACARD - Circuit protector	1	
-41	465 256	A	* FUSE HOLDER - (HKP-66)	2	
-42	461 623	A	* FUSE - 5 AMP	2	
-43	454 656	A	* CIRCUIT PROTECTOR - (2305)	6	
	454 657	A	* CIRCUIT PROTECTOR - (2310)	2	
	454 658	A	* CIRCUIT PROTECTOR - (2315)	1	
	454 659	A	* CIRCUIT PROTECTOR - (2320)	4	
	454 661	A	* CIRCUIT PROTECTOR - (2330)	1	
	454 662	A	* CIRCUIT PROTECTOR - (2350)	1	

A - Used on PA-30 with serial numbers 30-2 to 30-1716 inclusive, 30-1718 to 30-1744 inclusive.  
 B - Used on PA-30 with serial numbers 30-1717, 30-1745 and up, and PA-39 with serial numbers 39-1 and up.  
 C - Used on PA-30 with serial numbers 30-1717, 30-1745 and up, and PA-39 with serial numbers 39-1 to 39-145 inclusive.  
 D - Used with A. C. Spark Plug Instrument Cluster Assembly only.  
 E - Used with Rochester Gauge Instrument Cluster Assembly only.  
 Y - Used on PA-30 airplanes only.  
 Z - Used on PA-39 airplanes only.

When ordering, always specify Part Number, Description and Serial Number of Aircraft



Figure and Index Number	Part Number	Code	NOMENCLATURE	No. Req.	SERIAL NUMBERS AFFECTED
41-44	26695-00	Y	BRACKET ASSEMBLY - Shunt and fuse (complete)	1	30-1717, 30-1745 to 30-1780
	26895-00	YZ	BRACKET ASSEMBLY - Shunt and fuse (complete)	1	30-1781 and up, 39-1 and up
-45	23844-00	D	SHUNT ASSEMBLY	2	
-46	26655-00	Y	BRACKET ASSEMBLY - Shunt and fuse	1	30-1717, 30-1745 to 30-1780
	26893-00	YZ	BRACKET ASSEMBLY - Shunt and fuse	1	30-1781 and up, 39-1 and up
-47	43580-00	D	FUSE HOLDER PLATE ASSEMBLY	1	
-48	41679-00	YZ	COVER - Bracket assembly	1	30-1781 and up, 39-1 and up
-49	26967-00	D	PLACARD - Alternator fuse	1	
-50	26968-00	D	PLACARD - Battery shunt fuse	1	
-51	461 623	D	FUSE - 5 AMP	6	
52	487 820	Y	SWITCH - Micro, motor arm ( 8AS28)	1	30-2 to 30-675 inclusive
	25203-00	YZ	SWITCH - micro, motor arm	1	30-676 and up, 39-1 and up
-53	487 820	Y	SWITCH - Micro, limit arm ( 8AS28)	1	30-2 to 30-694 inclusive
	487 862	YZ	SWITCH - Micro, limit arm ( 1HC21-4)	1	30-695 and up, 39-1 and up
-54	17807-00	Y	GUARD - Limit switch	1	30-2 to 30-684 inclusive
-55	488 486		BLOCK - Terminal (MS25123-1-9)	2	
-56	23678-00	A	TUBE - Fuselage harness support	1	
	23678-02	Y	TUBE - Fuselage harness support	1	30-1717, 30-1745 to 30-1780
	23678-03	YZ	TUBE - Fuselage harness support	1	30-1781 and up, 39-1 and up
-57	60054-23	A	LINK - Fuselage harness support	1	
-58	571 098	C	KNOB - Map light rheostat ( 1400)	1	
	571 114	D	KNOB - Map light rheostat ( 103D)	1	
-59	19286-00	AB	CAPACITOR ASSEMBLY	1	
-60	31506-02	AB	BAR - Bus	1	
-61	454 662	AB	CIRCUIT PROTECTOR - ( 2350) Wood electric	1	
-62	25862-00	C	PLACARD - Map light (581 345)	1	
-63	23969-03		NIPPLE - Electrical terminal	4	
-64	17807-00		GUARD - Limit switch	1	
-65	31638-00		PANEL ASSEMBLY - Heated glass (complete)	1	
-66	31997-00		PLATE ASSEMBLY - Heated glass panel hinge	1	
-67	33034-00		BLOCK - Rubber	1	
-67a	23183-00		MOULDING - Rubber	2	
-68	31632-00		BRACKET - Socket	1	
-69	468 007		JACK - Banana, heated glass ( 108-902)	1	
-70	468 008		JACK - Banana, heated glass ( 108-903)	1	
-71	31633-00		PLATE ASSEMBLY - Heated glass receptacle	1	
-72	457 860	A	SWITCH - Heated windshield ( 2FA54-73)	1	
	32370-10	D	SWITCH - Heated windshield (12 Volt)	1	
-73	454 658		CIRCUIT PROTECTOR - Heated windshield ( 109-215-102)	1	
-74	25239-00	A	PLACARD - Windshield heat switch	1	

A - Used on PA-30 with serial numbers 30-2 to 30-1716 inclusive, 30-1718 to 30-1744 inclusive.  
 B - Used when Dual Generators are installed.  
 C - Used on PA-30 with serial numbers 30-1511 to 30-1716 inclusive, 30-1718 to 30-1744 inclusive.  
 D - Used on PA-30 with serial numbers 30-1717, 30-1745 and up, and PA-39 with serial numbers 39-1 and up.  
 Y - Used on PA-30 airplanes only.  
 Z - Used on PA-39 airplanes only.

When ordering, always specify Part Number, Description and Serial Number of Aircraft

SECTION VII  
Electrical System Group



Figure and Index Number	Part Number	Code	NOMENCLATURE	No. Req	SERIAL NUMBERS AFFECTED
41-75	31893-02	Y	CORD AND SWITCH ASSEMBLY - Electric trim	1	30-2 to 30-1510 inclusive.
	25839-00	C	CORD AND SWITCH ASSEMBLY - Electric trim (with map light)	1	
-76	487 859	C	SWITCH - (=8868K2)	1	
-77	24641-00	C	HOOD ASSEMBLY - Connector	1	
-78	25596-00	C	PLACARD - Trim switch	1	
-79	80042-71	A	PLATE - Insulating, circuit protector panel, 5 1/2" x 4 3/8"	1	
-80	80042-72		PLATE - Insulating, circuit protector panel, 7" x 4 1/8"	2	
-81	80042-73	A	PLATE - Insulating, circuit protector panel, 6 3/4" x 6 3/4"	1	
-82	80042-74		PLATE - Insulating, circuit protector panel, 3 3/4" x 3 1/2"	1	
-83	21524-03	E	BOX ASSEMBLY - Battery	1	
-84	17604-24	E	CABLE ASSEMBLY	1	
-85	13586-57	E	TUBE - Plastic	1	
-86	17566-02	E	LID ASSEMBLY - Battery box	1	
-87	13586-87	E	TUBE - Battery vent, plastic	1	
-88	22369-27	E	TUBE - Battery vent, plastic	1	
-89	22369-11	E	TUBE - Battery box, plastic	1	
-90	17555-00	E	PLATE - Battery terminal	1	
-91	14226-19	E	WIRE ASSEMBLY - Battery to solenoid	1	
-92	14226-32	E	WIRE ASSEMBLY - Battery solenoid to starter solenoid	1	
-93	454 925	E	CLAMP - Battery tube (=18-882)	1	
-94	14069-00	E	TERMINAL ASSEMBLY - Battery cable	1	
-95	81342-56	E	WASHER - Battery terminal	1	
-96	23969-02	E	NIPPLE - Starter switch wire	4	
-97	23969-04	E	NIPPLE - Starter cable	7	
-98	450 035	E	BATTERY - (R-35) 12 Volt	1	
-99	487 149	A	SOLENOID - Starter (=001464)	2	
	487 163	D	SOLENOID - Starter (26898-06)	2	
-100	455 151	E	SWITCH - Magnetic (=6041H105)	1	
-101	450 386	AB	PARALLELING RELAY - (Lycoming =68628)	1	
-102	550 380	F	RELAY - Overvoltage (=X-17621)	2	
	484 183	Z	RELAY - Overvoltage (=B-00289-2)	2	39-146 and up

- A - Used on PA-30 with serial numbers 30-2 to 30-1716 inclusive, 30-1718 to 30-1744 inclusive.
- B - Used when Dual Generators are installed.
- C - Used on PA-30 with serial numbers 30-1511 to 30-1716 inclusive, 30-1718 to 30-1744 inclusive.
- D - Used on PA-30 with serial numbers 30-1717, 30-1745 and up, and PA-39 with serial numbers 39-1 and up.
- E - Used on PA-30 with serial numbers 30-853, 30-902 and up, and PA-39 with serial numbers 39-1 and up.
- F - Used on PA-30 with serial numbers 30-1717, 30-1745 and up, and PA-39 with serial numbers 39-1 to 39-145 inclusive.
- Y - Used on PA-30 airplanes only.
- Z - Used on PA-39 airplanes only.

When ordering, always specify Part Number, Description and Serial Number of Aircraft

## PIPER PARTS CATALOG

Figure and Index Number	Part Number	Code	NOMENCLATURE	No. Req.	SERIAL NUMBERS AFFECTED
41-103	450 385	A	REGULATOR - Voltage (Lycoming 72077)	1	
	450 385	AB	REGULATOR - Voltage (Lycoming 72077)	2	
	550 383	E	REGULATOR - Voltage (#VSF-7203)	2	
	550 393	Z	REGULATOR - Voltage (#B-00288-1)	2	39-146 and up
-104	487 878	A	SWITCH - (#9251) Circuit breaker door	1	
-105	472 050	A	BULB - (#1815) Circuit breaker door	1	
-106	487 804		SWITCH - Fuel selector valve (MS25253-1)	4	
-107	25855-02		LIGHT ASSEMBLY - Map	1	
-108	472 770		* LIGHT ASSEMBLY - Map (#15-0100-2)	1	
-109	25854-00	C	RHEOSTAT ASSEMBLY - Map light	1	
	25854-02	D	RHEOSTAT ASSEMBLY - Map light	1	
-110	26934-00		CORD ASSEMBLY - Electric trim and boom mike (555 374)	1	
-111	761 039	DV	KIT - Electric trim switch replacement	1	
-112	487 804		SWITCH - Limit (MS25253-1) Throttle	1	
	487 940		SWITCH - Limit (AN3234-2) Throttle	2	
-113	44180-00	D	FILTER - Regulator (460 614)	2	
-114	18418-02		PLATE - Throttle switch actuator	1	
-115	24154-00		PLATE - Switch insulator	1	
-116	31494-00	D	FILTER ASSEMBLY - Alternator	2	
-117	32944-03	Y	BOX ASSEMBLY - Relay, alternator field control (complete)	1	30-1717, 30-1745 and up
	32951-03	Z	BOX ASSEMBLY - Relay, alternator field control (complete)	1	39-1 to 39-145 inclusive
-118	484 254	YZ	* RELAY - (#KA11DG) 10 AMP, DPDT, 12 VDC	2	
-119	596 058		FILTER - Magneto	4	

A - Used on PA-30 with serial numbers 30-2 to 30-1716 inclusive. 30-1718 to 30-1744 inclusive.  
 B - Used when Dual Generators are installed.  
 C - Used on PA-30 with serial numbers 30-1511 to 30-1716 inclusive. 30-1718 to 30-1744 inclusive.  
 D - Used on PA-30 with serial numbers 30-1717, 30-1745 and up, and PA-39 with serial numbers 39-1 and up.  
 E - Used on PA-30 with serial numbers 30-1717, 30-1745 and up, and PA-39 with serial numbers 39-1 to 39-145 inclusive.  
 V - These parts must be ordered from Service Spares Department, Piper Aircraft Corporation, Vero Beach, Florida.  
 Y - Used on PA-30 airplanes only.  
 Z - Used on PA-39 airplanes only.

When ordering, always specify Part Number, Description and Serial Number of Aircraft

1K22 THRU 1K24  
INTENTIONALLY LEFT BLANK

# PIPER PARTS CATALOG

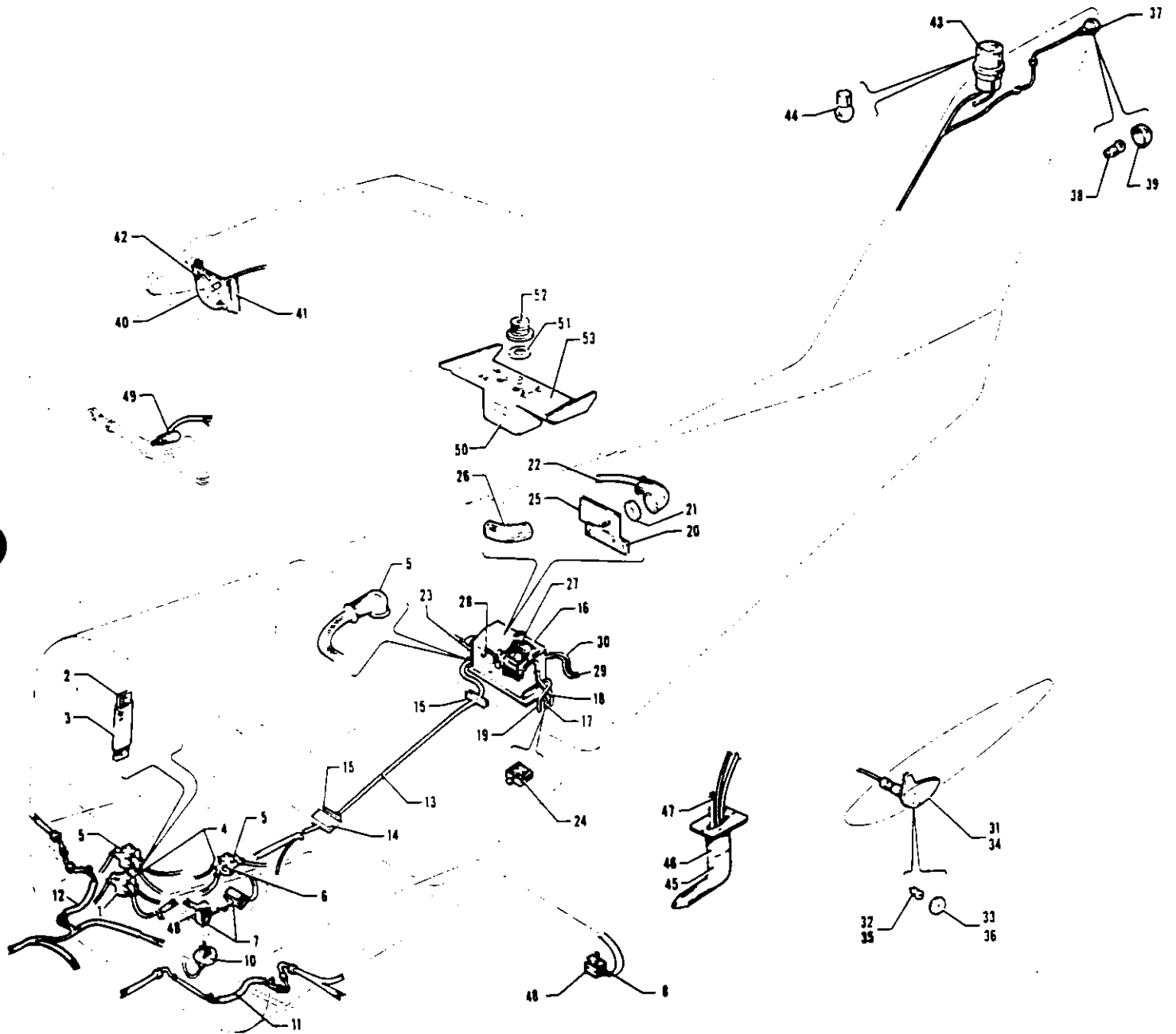

Figure 42. Electrical System - Aft

REVISED MAY 1980



Figure and Index Number	Part Number	Code	NOMENCLATURE	No. Req.	SERIAL NUMBERS AFFECTED
42-	23700	B	DRAWING - Electrical System Installation		
	26651	C	DRAWING - Electrical System Installation		
	24138	A	DRAWING - Battery Box Installation		
	24244	B	DRAWING - Heated Pitot Tube Installation		
	26732	C	DRAWING - Heated Pitot Tube Installation		
	24889	B	DRAWING - Electric Stabilator Trim Installation		
	26754	C	DRAWING - Electric Stabilator Trim Installation		
-1	487 149	A	SOLENOID - Starter (#001464)	2	
-2	17604-19	A	CABLE ASSEMBLY - Ground	1	
-3	13586-58	A	TUBE - Plastic	1	
-4	23969-02	A	NIPPLE - Terminal	3	
-5	23969-04	A	NIPPLE - Terminal	7	
-6	21061-00	B	SOLENOID - Flap motor	1	
	487 152	C	SOLENOID - Flap motor (26898-03)	1	
-7	487 805		MICRO SWITCH - (#BZ-7RQ31T1/1PA15)	2	
-8	487 820	Y	MICRO SWITCH - Safety (left gear only) (#8AS28)	1	30-2 to 30-694 inclusive
	487 863	YZ	MICRO SWITCH - Safety (left gear only) (#1CH22-4)	1	30-695 and up, 39-1 and up.
-9	17807-00		GUARD - Limit switch	2	
-10	22663-00		UNIT ASSEMBLY - Flap position indicator sending	1	
-11	13586-40		TUBE - Plastic	1	
-12	13586-41		TUBE - Plastic	1	
-13	14226-36	A	WIRE ASSEMBLY - Battery	1	
-14	22073-00	A	BLOCK ASSEMBLY - Rub	1	
-15	22407-00	A	BLOCK - Wire retaining	4	
-16	17566-02	A	LID ASSEMBLY - Battery box	1	
-17	22369-02	A	TUBE - Plastic (3-1/4 L)	1	
-18	22369-03	A	TUBE - Plastic (9-1/4 L)	1	
-19	22369-04	A	TUBE - Plastic (21-1/4 L)	1	
-20	14069-00	A	TERMINAL ASSEMBLY	1	
-21	81342-56	A	WASHER	1	
-22	14226-19	A	WIRE ASSEMBLY - Battery	1	
-23	455 151	A	SWITCH - Magnetic (#6041H105)	1	
-24	454 925	A	CLAMP - Battery tube (#18-882)	1	
-25	17555-00	A	PLATE	1	
-26	13586-58	A	TUBE - Plastic	1	
-27	450 035	A	BATTERY - (R-35) 12 Volt	1	
-28	21524-02	A	BOX ASSEMBLY - Battery	1	
-29	17604-14	A	CABLE ASSEMBLY	1	
-30	13586-57	A	TUBE - Plastic	1	

A - Used on PA-30 with serial numbers 30-2 to 30-852 inclusive, 30-854 to 30-901 inclusive. See Figure 41 for PA-30 with serial numbers 30-853, 30-902 and up, and PA-39 with serial numbers 39-1 and up.  
 B - Used on PA-30 with serial numbers 30-2 to 30-1716 inclusive, 30-1718 to 30-1744 inclusive.  
 C - Used on PA-30 with serial numbers 30-1717, 30-1745 and up, and PA-39 with serial numbers 39-1 and up.  
 Y - Used on PA-30 airplanes only.  
 Z - Used on PA-39 airplanes only.

When ordering, always specify Part Number, Description and Serial Number of Aircraft



PIPER PARTS CATALOG

Figure and Index Number	Part Number	Code	NOMENCLATURE	No. Req.	SERIAL NUMBERS AFFECTED
42-31	472 665		LIGHT - Red, left wing (#A1285)	1	
-32	751 381		* BULB - (#1512)	1	
-33	751 202		* LENS - Red	1	
-34	472 666		LIGHT - Green, right wing (#A1285)	1	
-35	751 381		* BULB - (#1512)	1	
-36	751 201		* LENS - Green	1	
-37	472 736		LIGHT - White, tail (#A2064-1073)	1	
-38	753 431		* BULB - Tail light (#1073)	1	
-39	751 203		* LENS - White	1	
-40	472 661		LIGHT - Landing (#4509)	1	
-41	20345-00		BRACKET - Landing light	1	
-42	20347-02		CLAMP - Landing light	4	
-43	452 410	B	BEACON - Rotating	1	
-44	758 402	B.V	* BULB	1	
-45	21301-00		TUBE - Pitot, heated	1	
-46	21299-00		MAST ASSEMBLY - Pitot tube	1	
-47	83161-27		HOSE - Pitot tube, 6" L	1	
-48	17807-00	Y	GUARD - Safety switch (left gear)	1	30-2 to 30-694 inclusive
-49	487 820	Y	MICRO SWITCH - Main gear (#8AS28)	2	30-2 to 30-694 inclusive
	487 863	YZ	MICRO SWITCH - Main gear, left (#1CH22-4)	1	30-695 and up, 39-1 and up
	487 864	YZ	MICRO SWITCH - Main gear, right (#1CH23-4)	1	30-695 and up, 39-1 and up
-50	24704-00	AC	SERVO ASSEMBLY - Electric trim (complete) (Piper)	1	
	27129-02	AC	SERVO ASSEMBLY - Electric trim (complete) (Mitchell)	1	
-51	494 159	DV	* WASHER - Servo friction (24696-00)	1	
-52	581 126	DV	* PLATE - Servo clutch, outer (24695-00)	1	
-53	24624-00		BRACKET ASSEMBLY - Servo mounting	1	

A - See Figure 51 if AltiMatic II is installed or Figure 52 if AltiMatic III is installed.  
 B - See Figure 42E if Anti-Collision Red Strobe Light is installed.  
 C - Ascertain existing servo manufacturer, either Piper or Mitchell, and order accordingly.  
 D - Used on Piper Servo only.  
 V - These parts must be ordered from Service Spares Department, Piper Aircraft Corporation, Vero Beach, Florida.  
 Y - Used on PA-30 airplanes only.  
 Z - Used on PA-39 airplanes only.

When ordering, always specify Part Number, Description and Serial Number of Aircraft

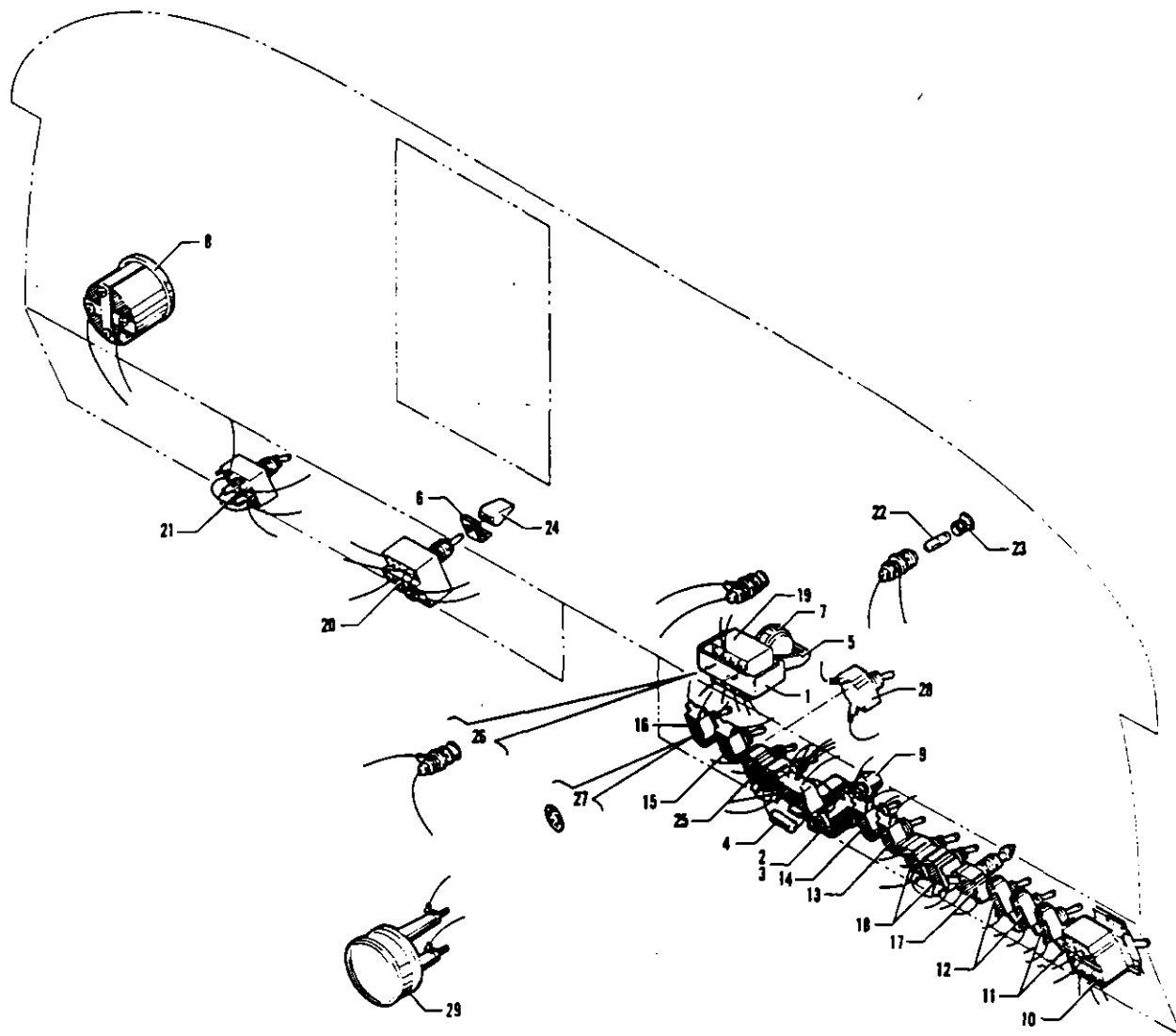

Figure 42A. Cockpit Electrical Installation  
(PA-30 with Serial Nos. 30-2 to 30-1716, 30-1718 to 30-1744 inclusive)

PIPER PARTS CATALOG

Figure and Index Number	Part Number	Code	NOMENCLATURE	No. Req.	SERIAL NUMBERS AFFECTED
42A-	23945 25646	B	DRAWING - Fuselage Harness Installation DRAWING - Fuselage Harness Installation		30-2 to 30-1101 inclusive
-1	22248-00		GUARD ASSEMBLY - Landing gear actuator switch	1	
-2	22858-03		RHEOSTAT ASSEMBLY - (Complete)	1	30-2 to 30-931 inclusive
	22858-05		RHEOSTAT ASSEMBLY - (Complete)	1	30-932 to 30-1101 inclusive
	22858-06	B	RHEOSTAT ASSEMBLY - (Complete)	1	
-3	484 582		* RHEOSTAT ASSEMBLY	1	30-2 to 30-931 inclusive
	484 583	D	* RHEOSTAT ASSEMBLY	1	
-4	484 411		* RESISTOR - Rheostat	1	
-5	23210-02		GUARD ASSEMBLY - Landing gear switch	1	
-6	23229-00		BRACKET - Flap switch	1	
-7	23347-00		KNOB - Landing gear switch	1	
-8	23857-00		AMMETER ASSEMBLY	1	
-9	471 068		KNOB - Instrument light rheostat (M88010-4)	1	
-10	487 803		SWITCH - Master (#8740K9)	1	
-11	487 790		SWITCH - Magneto (#110-S-73) Left engine	2	
-12	487 790		SWITCH - Magneto (#110-S-73) Right engine	2	
-13	487 790		SWITCH - Rotating beacon (#110-S-73)	1	
-14	487 790		SWITCH - Position lights (#110-S-73)	1	
-15	487 790		SWITCH - Left generator (#110-S-73)	1	
-16	487 790	AC	SWITCH - Right generator (#110-S-73)	1	
-17	762 418		SWITCH - Starter (#8503K12)	1	
-18	487 828		SWITCH - Left fuel pump (#8801K13)	1	
	487 828		SWITCH - Right fuel pump (#8801K13)	1	
-19	487 845		SWITCH - Landing gear (#4TL66-1L)	1	30-2 to 30-694 inclusive
	487 865	E	SWITCH - Landing gear (#4TL66-3F)	1	
-20	487 839		SWITCH - Flap (#4TL57-1)	1	
-21	18774-00		SWITCH - Heater	1	30-2 to 30-401 inclusive
	487 858	F	SWITCH - Heater (#2GM74-73)	1	
-22	472 054		BULB - Indicator light (PS10008-330)	3	
-23	472 332		LENS - Indicator light, amber	1	
	472 333		LENS - Indicator light, green	1	
	472 334		LENS - Indicator light, red	1	
-24	23943-00		KNOB - Flap switch	1	
-25	487 828		SWITCH - Left landing light	1	
	487 828		SWITCH - Right landing light	1	
-26	472 694		INDICATOR - Light (less lens)	3	
-27	494 055	AC	LOCK WASHER - (#16-886)	1	
-28	487 860	A	SWITCH - Heated pitot tube (#2FA54-73)	1	
-29	565 288		HORN - Stall warning (#02404-1)	1	

- A - Used on PA-30 with serial numbers 30-2 to 30-1716 inclusive, 30-1718 to 30-1744 inclusive.
- B - Used on PA-30 with serial numbers 30-1102 to 30-1716 inclusive, 30-1718 to 30-1744 inclusive.
- C - Used when Dual Generators are installed.
- D - Used on PA-30 with serial numbers 30-932 to 30-1716 inclusive, 30-1718 to 30-1744 inclusive.
- E - Used on PA-30 with serial numbers 30-695 to 30-1716 inclusive, 30-1718 to 30-1744 inclusive.
- F - Used on PA-30 with serial numbers 30-402 to 30-1716 inclusive, 30-1718 to 30-1744 inclusive.

When ordering, always specify Part Number, Description and Serial Number of Aircraft

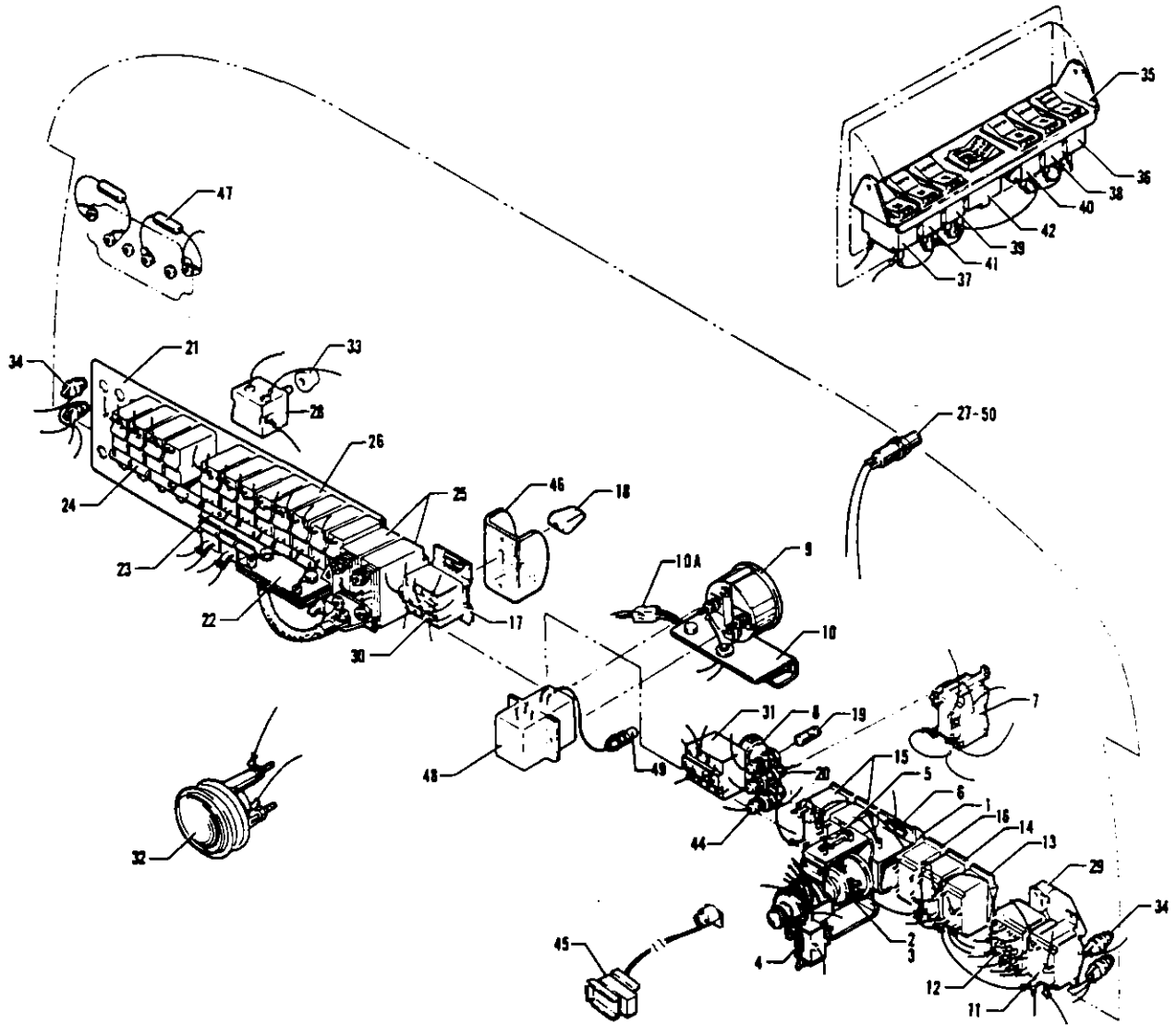

Figure 42B. Cockpit Electrical Installation  
 (PA-30 with Serial Nos. 30-1717, 30-1745 and up)  
 (PA-39 with Serial Nos. 39-1 and up)



Figure and Index Number	Part Number	Code	NOMENCLATURE	No. Req.	SERIAL NUMBERS AFFECTED
42B-	27545 26638	D Z	DRAWING - Fuselage Harness Installation DRAWING - Fuselage Harness Installation		39-146 and up
-1	571 112		KNOB - Instrument lights (105D)	1	
-2	32603-03	B	SWITCH ASSEMBLY - Dimmer	1	
-3	19857-00	B	RHEOSTAT ASSEMBLY - Dimmer	1	
-4	484 380	B	RESISTOR - Rheostat (BW-2)	1	
-5	484 443	B	RESISTOR - Rheostat (F105)	1	
-6	26369-00	B	BRACKET ASSEMBLY - Rheostat	1	
-7	32370-09		SWITCH - Heated pitot tube	1	
-8	23347-00		KNOB - Landing gear switch	1	
-9	23857-00		AMMETER ASSEMBLY	1	
-10	26636-00	E	SWITCH ASSEMBLY - Alternator test	1	
	27254-00	Z	SWITCH ASSEMBLY - Alternator test	1	39-127 and up
-10a	27255-00	Z	HARNESS ASSEMBLY - Alternator test	1	39-127 and up
-11	32370-02	D	SWITCH - Master	1	
	27274-00	Z	SWITCH - Master	1	39-146 and up
-12	487 852	D	SWITCH - Voltage regulator (1L254-73)	1	
-13	32370-04		SWITCH - Navigation lights	1	
-14	32370-15		SWITCH - Anti-collision, red	1	
-15	32370-05		SWITCH - Landing lights	2	
-16	32370-16		SWITCH - Anti-collision, white	1	
-17	26774-00		BRACKET - Flap switch	1	
-18	23943-00		KNOB - Flap switch	1	
-19	472 054		BULB - Indicator light (PS10008-330)	4	
-20	472 332		LENS - Indicator light, amber	1	
	472 333		LENS - Indicator light, green	1	
	472 338		LENS - Indicator light, white	1	
-21	26610-02		PANEL ASSEMBLY - Circuit protector	1	
-22	23844-00		SHUNT ASSEMBLY	1	
-23	31506-02		BAR - Bus	10	
-24	31506-06		BAR - Bus	3	
-25	454 667	C	CIRCUIT BREAKER - (302-290-102) 90 AMP	2	
	454 712	Z	CIRCUIT BREAKER - (616-290-102) 90 AMP	2	39-139 and up
-26	454 661		CIRCUIT BREAKER - (109-230-102) 30 AMP	1	
	454 659		CIRCUIT BREAKER - (109-220-102) 20 AMP	2	
	454 658		CIRCUIT BREAKER - (109-215-102) 15 AMP	1	
	454 657		CIRCUIT BREAKER - (109-210-102) 10 AMP	8	
	454 656		CIRCUIT BREAKER - (109-205-102) 5 AMP	7	
<p>A - Used on PA-30 with serial numbers 30-1717, 30-1745 and up, and PA-39 with serial numbers 39-1 and up.                      B - Used on PA-30 with serial numbers 30-1717, 30-1745 to 30-1886 inclusive, and 30-1888.                      C - Used on PA-30 with serial numbers 30-1717, 30-1745 and up, and PA-39 with serial numbers 39-1 to 39-138 inclusive.                      D - Used on PA-30 with serial numbers 30-1717, 30-1745 and up, and PA-39 with serial numbers 39-1 to 39-145 inclusive.                      E - Used on PA-30 with serial numbers 30-1717, 30-1745 and up, and PA-39 with serial numbers 39-1 to 39-126 inclusive.                      Y - Used on PA-30 airplanes only.                      Z - Used on PA-39 airplanes only.</p>					

When ordering, always specify Part Number, Description and Serial Number of Aircraft



Figure and Index Number	Part Number	Code	NOMENCLATURE	No. Req.	SERIAL NUMBER AFFECTED
42B-27	472 741		LIGHT ASSEMBLY - Stall warning (911-1112-1631-525) (less bulb)	1	
-28	487 957		SWITCH - Heater fan ( 70305) (knob type)	1	
	587 899		SWITCH - Heater fan ( 2GG54-73) (toggle)	1	
-29	463 600	B	GUARD - Switch (8497K1)	1	
-30	487 839		SWITCH - Flap (4TL57-1)	1	
-31	487 865		SWITCH - Landing gear (4TL66-3F)	1	
-32	565 288		HORN - Stall warning (02404-1)	1	
-33	571 112		KNOB - Heater fan switch (105D)	1	
-34	468 002		JACK - Mike (S12B)	2	
	468 006		JACK - Phone (11)	2	
-35	26620-00		PANEL - Switch	1	
-36	32370-07	Y	SWITCH - Fuel pump, left engine, white	1	
	32370-18	Z	SWITCH - Fuel pump, left engine, red	1	
-37	32370-08	Y	SWITCH - Fuel pump, right engine, white	1	
	32370-19	Z	SWITCH - Fuel pump, right engine, red	1	
-38	32371-02		SWITCH - Left magneto, left engine	1	
-39	32371-02		SWITCH - Left magneto, right engine	1	
-40	32371-03		SWITCH - Right magneto, left engine	1	
-41	32371-03		SWITCH - Right magneto, right engine	1	
-42	487 998		SWITCH - Micro (1TP12-7)	1	
-43	41554-00		PLACARD - Switch	1	
-44	472 694		INDICATOR - Light (less lens)	3	
-45	47732-05	YZ	DIMMER ASSEMBLY - Instrument lights	1	30-1887, 30-1889 and up, 39-1 and up
-46	26356-00		GUARD - Flap switch	1	
-47	30234-00		CAPACITOR ASSEMBLY	2	
-48	587 863	CZ	MONITOR - Voltage (A-00258-1)	2	39-146 and up
-49	472 862	CZ	LIGHT - Indicator, alternator, inoperative	2	39-146 and up
-50	472 028		BULB - Stall warning (PS10008-327)	1	

A - Used on PA-30 with serial numbers 30-1717, 30-1745 and up, and PA-39 with serial numbers 39-1 and up.  
 B - Used on PA-30 with serial numbers 30-1717, 30-1745 and up, and PA-39 with serial numbers 39-146 inclusive.  
 C - Also used on PA-30 with serial numbers 30-1717, 30-1745 to 30-2000 inclusive, and PA-39 with serial numbers 39-1 to 39-146 inclusive, if Alternator Warning Light Installation Kit 760 744 has been installed.  
 Y - Used on PA-30 airplanes only.  
 Z - Used on PA-39 airplanes only.

When ordering, always specify Part Number, Description and Serial Number of Aircraft

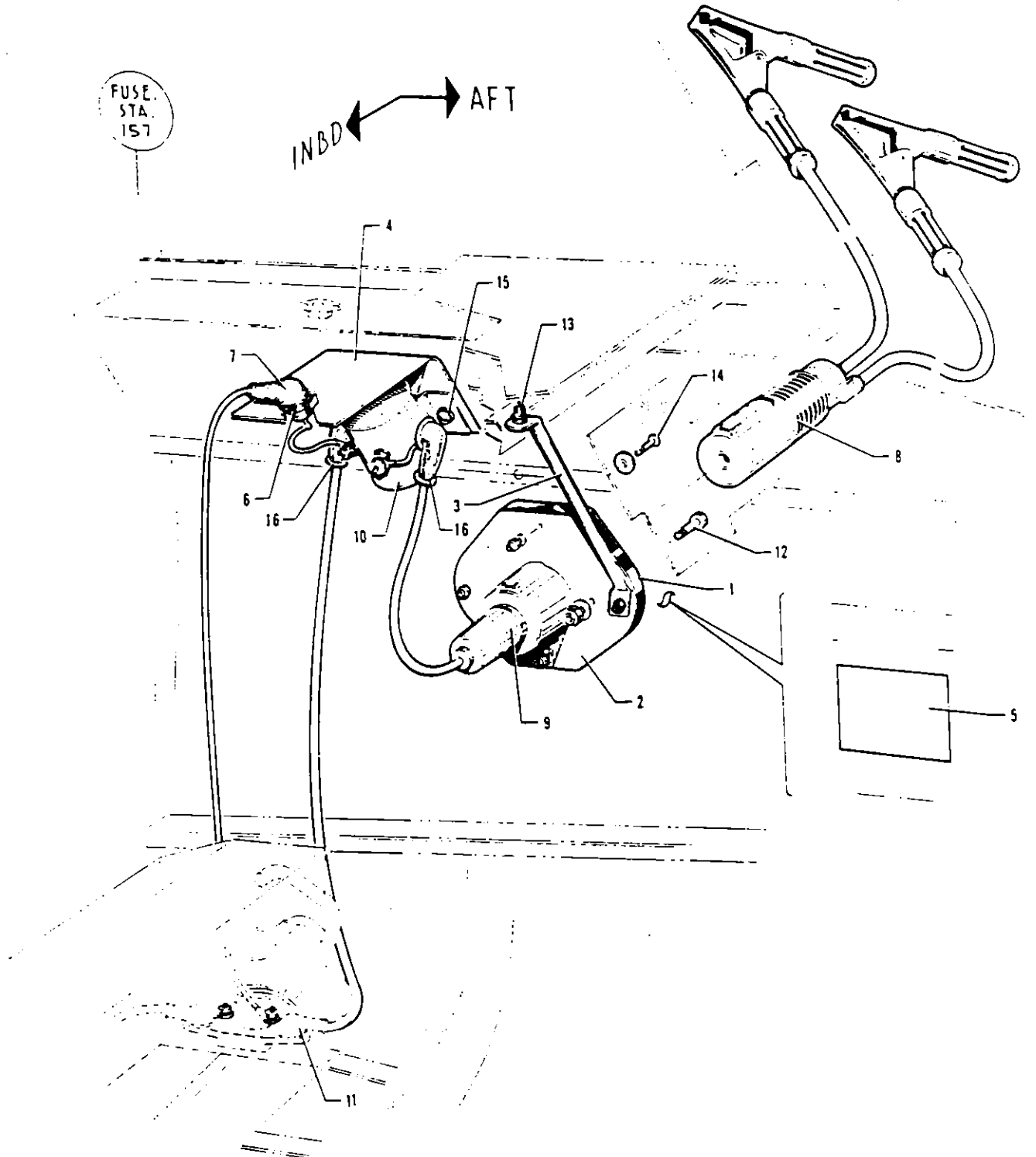

Figure 42C. External Power Supply  
(PA-30 with Serial Nos. 30-2 to 30-852, 30-854 to 30-901 inclusive)



Figure and Index Number	Part Number	Code	NOMENCLATURE	No. Req.	SERIAL NUMBERS AFFECTED
42C-	24628		DRAWING - External Power Supply Installation		
-1	62226-00		SPACER - Auxiliary power receptacle	1	
-2	62227-00		PLATE - Auxiliary power receptacle	1	
-3	62228-00		TUBE - Auxiliary power receptacle support	1	
-4	62342-00		BRACKET - Power relay	1	
-5	62343-00		PLACARD - External power	1	
-6	456 728		DIODE - (=1N3208)	1	
-7	476 673		NIPPLE - (MS25171-15)	1	
-8	62355-02		PLUG ASSEMBLY - Power connector	1	
-9	62355-03		SOCKET ASSEMBLY - Power connector	1	
-10	484 373		SOLENOID - (=24059)	1	
-11	453 171		BOOT - (#5466)	1	
-12	401 186		BOLT - (AN5-6A)	2	
	407 566		WASHER - (AN960-516)	2	
	404 837		NUT - (MS20364-524C)	2	
-13	417 715		SCREW - (AN520-10R8)	1	
	407 104		WASHER - (AN935-10)	1	
	406 870		RIVNUT - (A10K-75)	1	
-14	416 794		SCREW - (AN307-1032-R14)	4	
	494 087		WASHER - (A3235-020-1)	4	
	407 564		WASHER - (AN960-10)	4	
	404 835		NUT - (MS20364-1032C)	4	
-15	417 715		SCREW - (AN520-10R8)	2	
	407 104		WASHER - (AN935-10)	2	
	81342-13		WASHER	2	
	406 870		RIVNUT - (A10K-75)	2	
-16	23969-04		NIPPLE - Solenoid	2	

A - Used on PA-30 with serial numbers 30-2 to 30-852 inclusive, 30-854 to 30-901 inclusive.

When ordering, always specify Part Number, Description and Serial Number of Aircraft



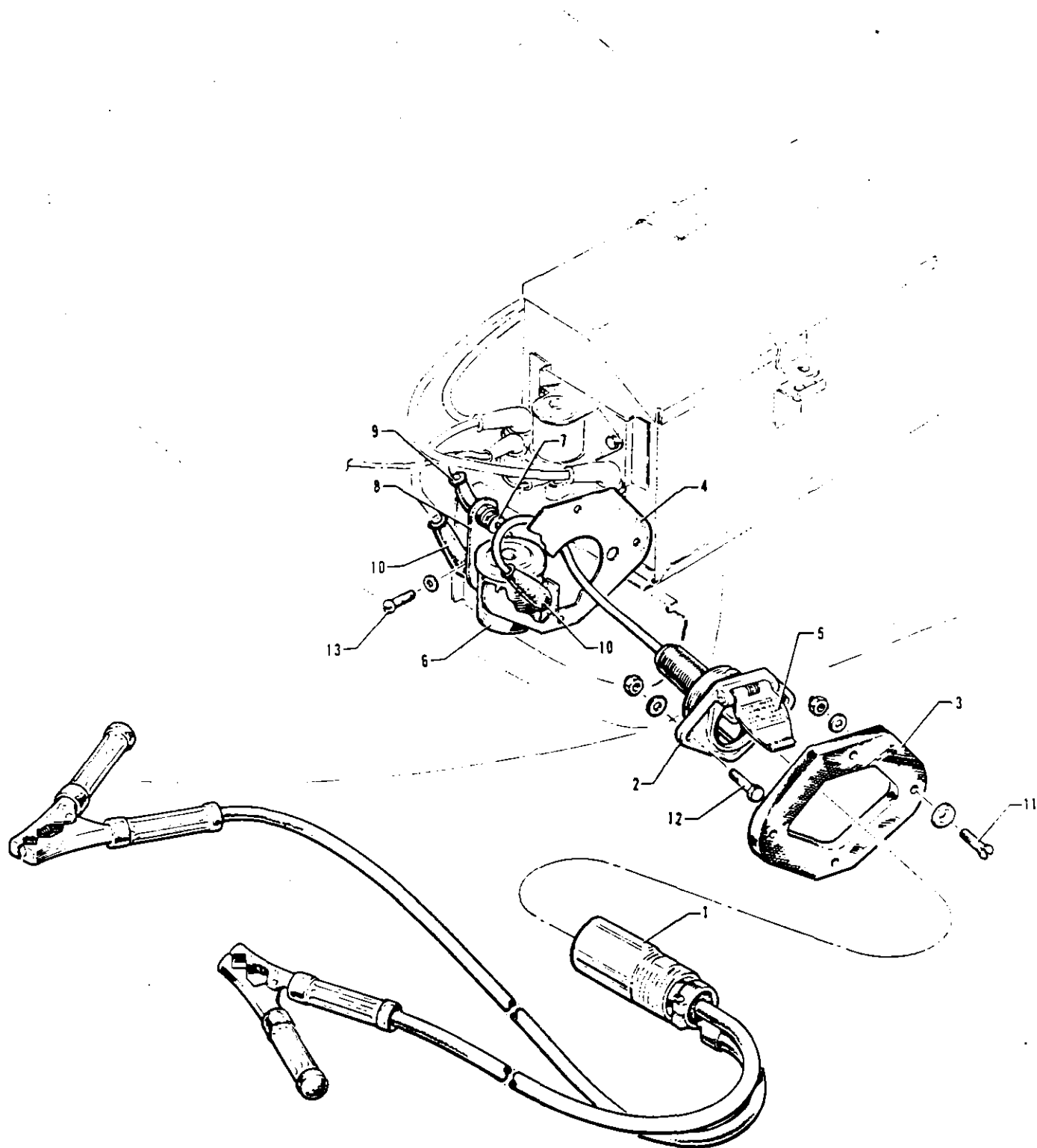

Figure 42D. External Power Supply  
 (PA-30 with Serial Nos. 30-853, 30-902 and up)  
 (PA-39 with Serial Nos. 39-1 and up)



Figure and Index Number	Part Number	Code	NOMENCLATURE	No Req	SERIAL NUMBERS AFFECTED
42D-	25585	B	DRAWING - External Power Supply Installation		
	26743	C	DRAWING - External Power Supply Installation		
-1	62355-02		PLUG ASSEMBLY - Power connector	1	
-2	62355-03		SOCKET ASSEMBLY - Power connector	1	
-3	62226-00		SPACER - Auxiliary power receptacle	1	
-4	62227-00		PLATE - Auxiliary power receptacle	1	
-5	62343-00	B	PLACARD - Auxiliary power receptacle	1	
	32739-00	C	PLACARD - Auxiliary power receptacle (with red lettering)	1	
	32739-02	C	PLACARD - Auxiliary power receptacle (with white lettering)	1	
-6	484 373		SOLENOID - (=24059)	1	
-7	456 728		DIODE - (1N3208)	1	
-8	25632-00	B	BRACKET - Diode mounting	1	
-9	23969-02	B	NIPPLE - Diode	1	
-10	23969-04		NIPPLE - Solenoid	2	
-11	416 794		SCREW - (MS24693-S275)	4	
	494 087		WASHER - (=A3235-020-1)	4	
	407 564		WASHER - (AN960-10)	4	
	404 835		NUT - (MS20365-1032C)	4	
	401 185		BOLT - (AN5-5A)	2	
-12	407 566		WASHER - (AN960-516)	2	
	404 837		NUT - (MS20364-524C)	2	
	411 532		SCREW - (MS35207-263)	2	
-13	407 564		WASHER - (AN960-10)	2	
	81342-13		WASHER	2	
	404 835		NUT - (MS20365-1032C)	2	
			<p>A - Used on PA-30 with serial numbers 30-853, 30-902 and up, and PA-39 with serial numbers 39-1 and up.                      B - Used on PA-30 with serial numbers 30-853, 30-902 to 30-1716 inclusive, 30-1718 to 30-1744 inclusive.                      C - Used on PA-30 with serial numbers 30-1717, 30-1745 and up, and PA-39 with serial numbers 39-1 and up.</p>		

When ordering, always specify Part Number, Description and Serial Number of Aircraft

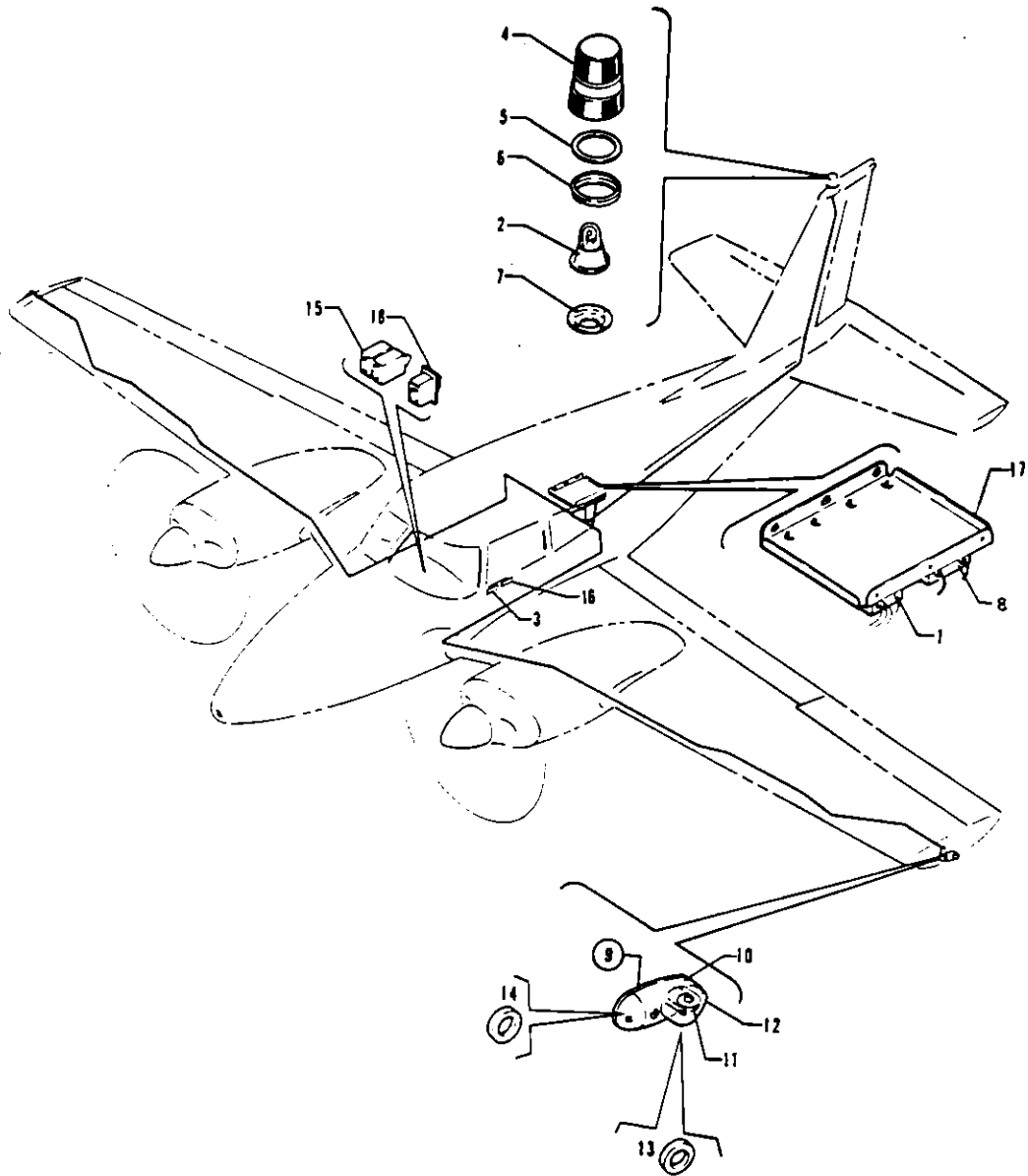

Figure 42E. Anti-Collision Strobe Light Installation

**PIPER PARTS CATALOG**

Figure and Index Number	Part Number	Code	NOMENCLATURE	No. Req.	SERIAL NUMBERS AFFECTED
42E-	27040 27045		DRAWING - Anti-Collision Red Strobe Light Installation DRAWING - Anti-Collision White Strobe Light Installation		
-1	481 214	A	POWER SUPPLY - Strobe light	1	
-2	757 762	A	LIGHT ASSEMBLY - Strobe	1	
-3	33038-00	B	PLACARD - Strobe light, tip	1	
-4	27046-02	A	LENS - Strobe light, red	1	
-5	755 042	A	GASKET - Strobe light	1	
-6	755 200	A	CLAMP ASSEMBLY - Ring	1	
-7	581 623	A	ADAPTER - Mounting plate (H102 "B")	1	
-8	763 469	B	POWER SUPPLY - Strobe light	1	
-9	761 158	B	LIGHT ASSEMBLY - Navigation and strobe, tip, red	1	
	761 159	B	LIGHT ASSEMBLY - Navigation and strobe, tip, green	1	
-10	756 037		* RETAINER - Light lens	1	
-11	761 156		* TUBE ASSEMBLY - Flash, tip	1	
-12	761 157		* LENS - Wing tip strobe	1	
-13	755 076		* GASKET - Wing strobe (A-427-4)	1	
-14	755 075		* GASKET - Navigation light (W1283)	1	
-15	454 656		CIRCUIT BREAKER - (109-205-102) 5 AMP	2	
-16	33048-00	A	PLACARD - Anti-collision, red strobe	1	
-17	27032-00		BRACKET ASSEMBLY - Power supply support	1	
-18	32370-16	B	SWITCH - Anti-collision, illuminated (487 781)	1	
			A - Used if anti-collision red strobe light is installed. B - Used if anti-collision white strobe lights are installed.		

When ordering, always specify Part Number, Description and Serial Number of Aircraft

1L15 THRU 1L24  
INTENTIONALLY LEFT BLANK



PA-30 AND PA-39  
***TWIN COMANCHE***  
PARTS CATALOG  
CARD 2 OF 2

PA-30

PA-39

**PIPER AIRCRAFT CORPORATION**

(PART NUMBER 753 646)

**2A1**

Island Enterprises

---

# PIPER PARTS CATALOG

---

## AEROFICHE EXPLANATION

The Parts Catalog information incorporated in this set of Aerofiche cards has been arranged in accordance with the general specifications of Aerofiche adopted by the General Aircraft Manufacturer's Association.

### Conversion of Aerofiche alpha/numeric code numbers:

First number is the Aerofiche card identifier.

Letter is the horizontal line reference per card.

Second number is the vertical line reference per card.

Example: 2J16=Aerofiche card number two of given set. Grid location J16.

To aid in locating the various sections and related information desired, the following is provided:

A complete Catalog Table of Contents is given at Grid 1A7 of Aerofiche card number 1 of this set. Each additional card in this set will have a Table of Contents for all sections on that particular card. This table will start at Grid A3.

## REVISIONS

The information compiled in this Aerofiche Parts Catalog will be kept current by revisions distributed periodically. These revisions will supersede all previous revisions and will be complete Aerofiche card replacements and shall supersede Aerofiche cards of the same number in the set.

Current Revisions to the PA-30 and PA-39 Parts Catalog issued February 1973 are as follows:

753 646 (PR770211).....	Dated February 1977
753 646 (PR800514).....	Dated May 1980
753 646 (PR820910).....	Dated September 1982

NOTE: Refer to the last card of the Piper Parts Price List - Aerofiche for a check list of current revision dates and card effectivities for this parts catalog.

# TABLE OF CONTENTS

FIGURE NUMBER	FIGURE TITLE	GRID NUMBER
SECTION VIII CONTROL SYSTEM GROUP		
43	Control Wheel Installation.....	2A4
44	Rudder Pedal Installation.....	2A8
45	Control Surfaces Control Systems.....	2A11
46	Flap Control Mechanism Installation.....	2A15
47	Rudder Trim Mechanism Installation.....	2A19
48	Stabilator Trim Mechanism Installation.....	2A23
SECTION IX ELECTRONICS GROUP		
49	AutoControl II Installation (PA-30 only).....	2B3
50	AutoControl III Installation.....	2B6
51	AltiMatic II Installation (PA-30 only).....	2B8
52	AltiMatic III and AltiMatic III B Installations.....	2B13
52A	AltiMatic Pilot III B-1 Installation (PA-39 only).....	2B18
53	Glide Slope Coupler Installation.....	2B21
54	Anti-Static Equipment Installation.....	2B23
54A	Piper Automatic Locator (ELT) Installation (Garrett Mfg. LTD).....	2C1
54B	Piper Automatic Locator (ELT) Installation (Narco Avionics).....	2C3
55	Piper PM-1 Marker Beacon Installation.....	2C5
56	Radio Junction Boxes (PA-30 S/N 30-2 to 30-1716, 30-1718 to 30-1744 incl.).....	2C7
57	Radio Junction Boxes (PA-30 S/N 30-1717, 30-1745 and up) (PA-39 S/N 39-1 to 39-145 inclusive).....	2C10
57A	Radio Junction Boxes (PA-39 S/N 39-146 and up).....	2C12
	Radio Drawings.....	2C14
SECTION X MISCELLANEOUS GROUP		
	Optional Equipment Kits and Repair Kits.....	2C16
	Decals.....	2C21
NUMERICAL INDEX		2D1



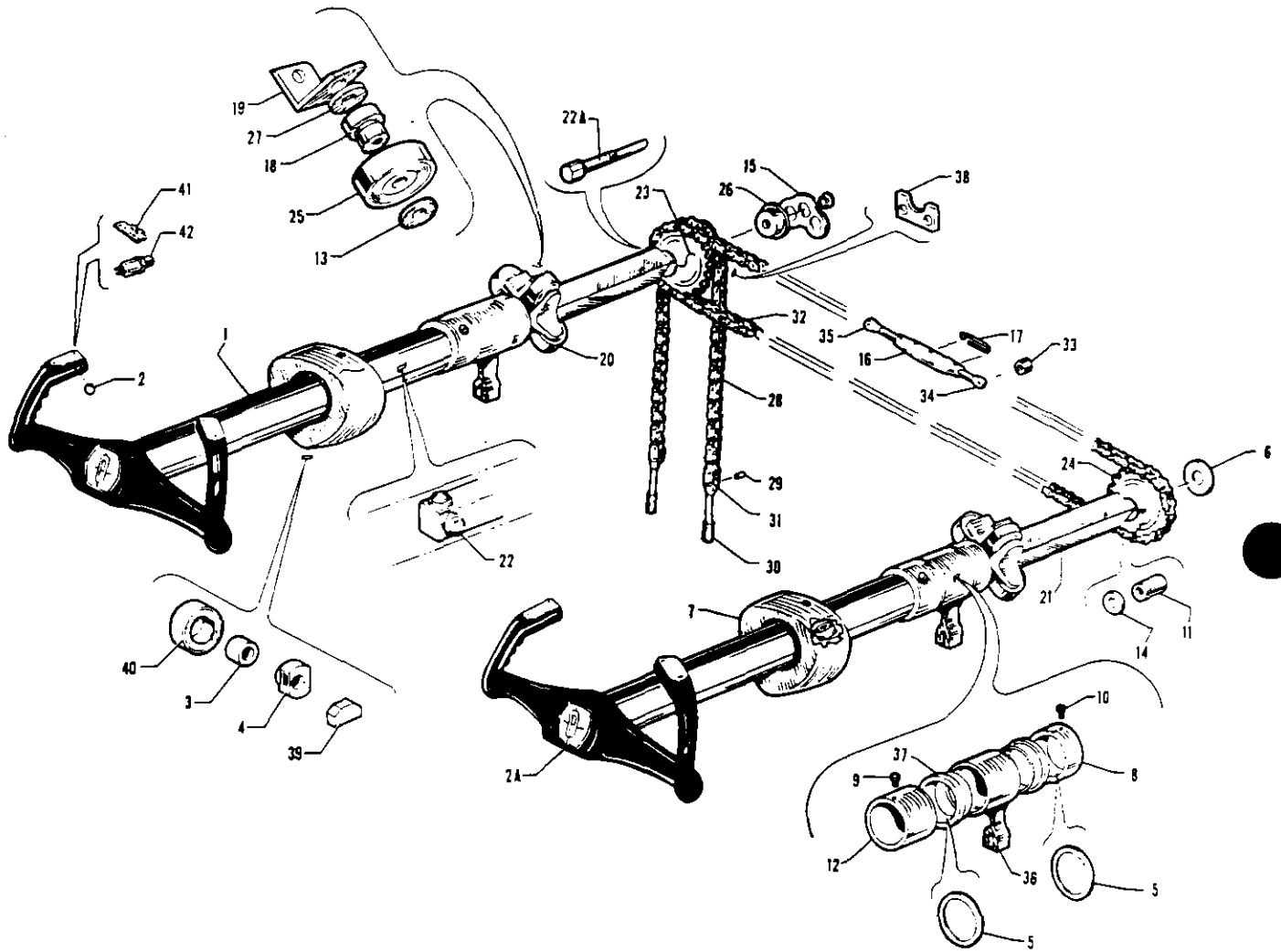

Figure 43. Control Wheel Installation

PIPER PARTS CATALOG

Figure and Index Number	Part Number	Code	NOMENCLATURE	No. Req.	SERIAL NUMBERS AFFECTED
43-	22988	Y	DRAWING - Control Wheel Installation		30-2 to 30-1700 inclusive
	26173	A	DRAWING - Control Wheel Installation		
	26689	D	DRAWING - Control Wheel Installation		
-1	20965-00	EY	WHEEL ASSEMBLY - Control, black (solid type)	2	30-2 to 30-707 inclusive
	20965-07	EY	WHEEL ASSEMBLY - Control, black (solid type)	2	30-708 to 30-1510 inclusive
	20965-10	BE	WHEEL ASSEMBLY - Control, black (solid type)	2	
	26665-02	D	WHEEL ASSEMBLY - Control, black (yoke type)	2	
-2	43255-02	D	* BUTTON - Plug	2	
-2a	20462-00	C	* MEDALLION ASSEMBLY - Control wheel (chrome and blue)	1	
	20462-02	C	* MEDALLION ASSEMBLY - Control wheel (bronze and tan)	1	
	20462-03	C	* MEDALLION ASSEMBLY - Control wheel (bronze and black)	1	
	20462-04	C	* MEDALLION ASSEMBLY - Control wheel (chrome and black)	1	
	474 345	D	* MEDALLION ASSEMBLY - Control wheel ( 8706-1)	1	30-1717, 30-1745 and up
-3	14976-06	Y	BUSHING	2	30-2 to 30-1700 inclusive
-4	21469-00	Y	BUSHING - Eccentric	2	30-2 to 30-1700 inclusive
-5	19513-14		WASHER - Seal	2	
-6	19513-16		WASHER - Seal	1	
-7	20928-00	Y	COVER - Control wheel shaft	2	30-2 to 30-1700 inclusive
	42537-00	Y	COVER - Control wheel shaft	2	30-1701 to 30-1716 inclusive, 30-1718 to 30-1744 inclusive
-8	20938-00		BEARING - Control wheel front	2	
-9	20995-00		STUD - Control wheel shaft rear bearing	2	
-10	20997-00		STUD - Control wheel shaft front bearing	4	
-11	21001-00		BUSHING - Spacer	1	
-12	21454-00		BEARING - Control wheel shaft rear	1	
-13	81342-92		WASHER	4	
-14	81342-93		WASHER	1	
-15	21998-00		WASHER - Seal	1	
-16	452 011		BARREL - Turnbuckle (NAS648-22-LS)	2	
-17	454 867		CLIP - Turnbuckle (NAS651-16S)	8	
-18	20956-00		BUSHING - Eccentric	4	
-19	20957-00		ANGLE - Corner support	2	
-20	20963-00		FITTING - Roller attachment	2	

A - Used on PA-30 with serial numbers 30-1701 to 30-1716 inclusive, 30-1718 to 30-1744 inclusive.  
 B - Used on PA-30 with serial numbers 30-1511 to 30-1716 inclusive, 30-1718 to 30-1744 inclusive.  
 C - Used on PA-30 with serial numbers 30-2 to 30-1716 inclusive, 30-1718 to 30-1744 inclusive.  
 D - Used on PA-30 with serial numbers 30-1717, 30-1745 and up, and PA-39 with serial numbers 39-1 and up.  
 E - "Solid Type" Control Wheel is no longer available, order "Yoke Type" Control Wheel P/N 26665-02 as a replacement.  
 Y - Used on PA-30 airplanes only.  
 Z - Used on PA-39 airplanes only.

When ordering, always specify Part Number, Description and Serial Number of Aircraft

PIPER PARTS CATALOG

Figure and Index Number	Part Number	Code	NOMENCLATURE	No. Req.	SERIAL NUMBERS AFFECTED
			1234567		
43-21	20975-03		TUBE ASSEMBLY - Control wheel shaft, left (with stud assembly)	1	
	20975-00		TUBE ASSEMBLY - Control wheel shaft, left (less stud assembly)	1	
	20975-00		TUBE ASSEMBLY - Control wheel shaft, right	1	
-22	21470-00		BLOCK - Rub	4	
-22a	23394-00		STUD ASSEMBLY - Control wheel sprocket, left	1	
-23	23323-00		SPROCKET ASSEMBLY - Double	1	
-24	20999-00		SPROCKET	1	
-25	452 369		BEARING	4	
-26	452 340		BEARING - (46677-00)	4	
-27	81342-89		WASHER - (0.012)	AR	
	81342-90		WASHER - (0.016)	AR	
	81342-91		WASHER - (0.020)	AR	
-28	21620-00	Y	CHAIN ASSEMBLY - Lower	1	30-2 to 30-1501 inclusive
	13445-07	YZ	CHAIN ASSEMBLY - Lower	1	30-1502 and up, 39-1 and up
-29	80012-95		BUSHING	2	
-30	459 930	Y	EYE - Turnbuckle (NAS648-22-RS)	4	30-2 to 30-1501 inclusive
-31	472 684		LINK - Connector, upper and lower	6	
-32	21819-00		CHAIN ASSEMBLY - Upper	1	
-33	80012-95		BUSHING	4	
-34	459 928		EYE - Turnbuckle (NAS648-22-LS)	2	
-35	459 930		EYE - Turnbuckle (NAS648-22-RS)	2	
-36	21450-00		BEARING ASSEMBLY - Control wheel shaft rear	1	
-37	20996-00		BEARING - Control wheel shaft rear	1	
-38	23322-00		STOP - Aileron, left	1	
-39	42538-00	YZ	SLIDE - Control wheel shaft	6	30-1701 and up, 39-1 and up
-40	14976-02	Y	BEARING - Bottom	2	30-2 to 30-1700 inclusive
	14976-03	Y	BEARING - Top	4	30-2 to 30-1700 inclusive
-41	43364-00		PLACARD - Boom mike (581 375)	1	
-42	487 904		SWITCH - Boom mike (#39-1)	1	

Y - Used on PA-30 airplanes only.  
Z - Used on PA-39 airplanes only.

When ordering, always specify Part Number, Description and Serial Number of Aircraft

**2 A7**

**INTENTIONALLY LEFT BLANK**

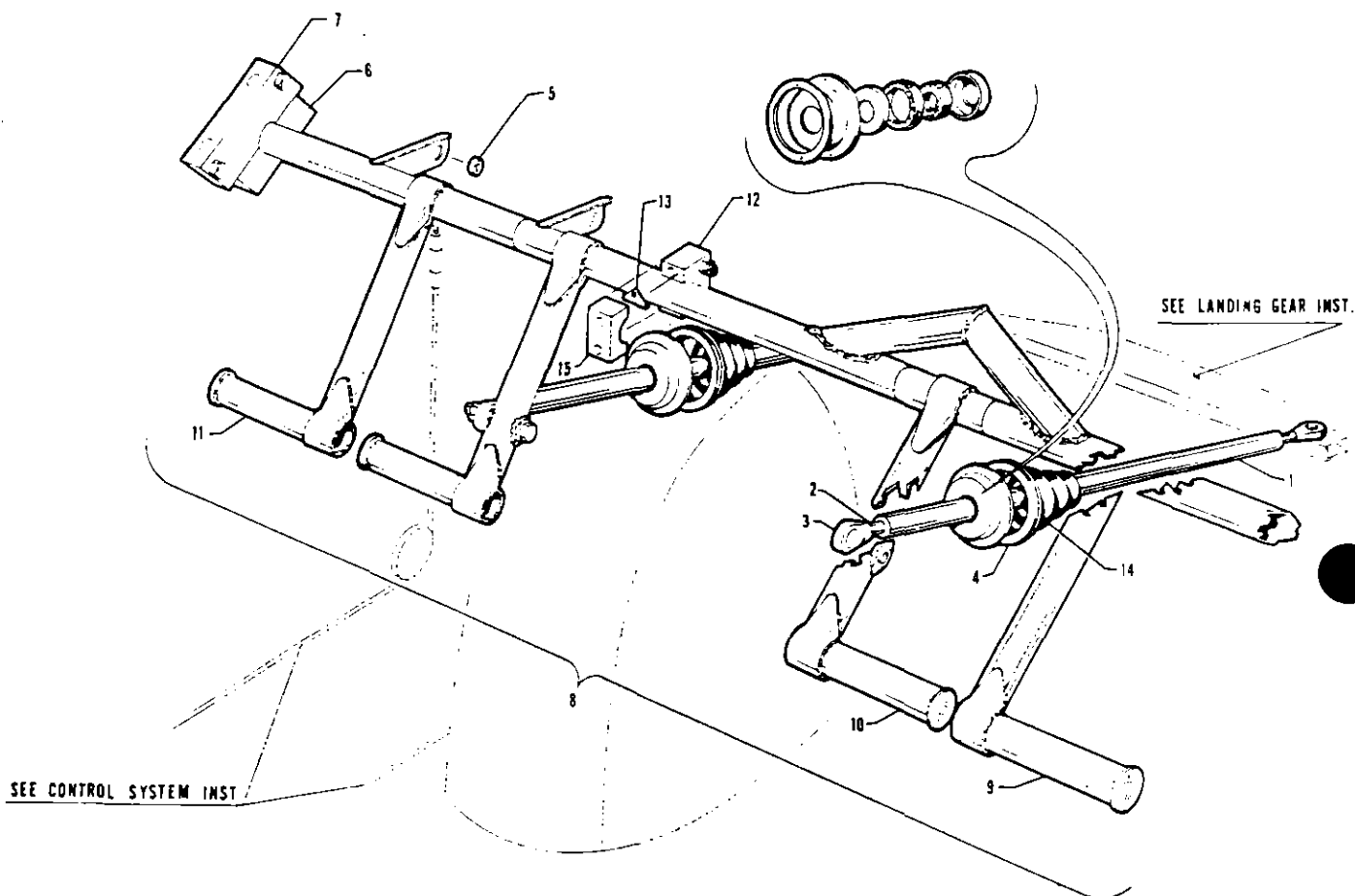

Figure 44. Rudder Pedal Installation



Figure and Index Number	Part Number	Code	NOMENCLATURE	No. Req.	SERIAL NUMBERS AFFECTED
44-	23869		DRAWING - Rudder Pedal Installation		
-1	20873-03	A	ROD ASSEMBLY - Nose wheel control	2	
	20873-05	Z	ROD ASSEMBLY - Nose wheel control	2	39-84 and up
-2	23757-02		BUSHING - Spacer	2	
-3	452 383		BEARING ASSEMBLY - (24166-00)	2	
-4	21377-00		PLATE - Nose wheel steering rod boot, left	1	
	24226-00		PLATE - Nose wheel steering rod boot, right	1	
-5	14843-48		BUSHING - Torque tube	2	
-6	17203-02		BLOCK - Rudder pedal torque tube, left	1	
	17203-03		BLOCK - Rudder pedal torque tube, right	1	
-7	20488-02		BLOCK - Rudder pedal tube, left, upper	1	
	20488-03		BLOCK - Rudder pedal tube, right, upper	1	
-8	23871-00	A	TUBE ASSEMBLY - Rudder pedal torque	1	
	27118-00	Z	TUBE ASSEMBLY - Rudder pedal torque	1	39-84 and up
-9	22207-00	A	TUBE ASSEMBLY - Rudder pedal torque, right	1	
	27110-00	Z	TUBE ASSEMBLY - Rudder pedal torque, right	1	39-84 and up
-10	20882-08		TUBE ASSEMBLY - Rudder pedal torque, center	1	
-11	22239-00	A	TUBE ASSEMBLY - Rudder pedal torque, left	1	
	27116-00	Z	TUBE ASSEMBLY - Rudder pedal torque, left	1	39-84 and up
-12	22205-00		BEARING - Rudder pedal torque tube	1	
-13	41371-02		SHIM - Rudder pedal torque bearing, .010	AR	
	41371-03		SHIM - Rudder pedal torque bearing, .015	AR	
	41371-04		SHIM - Rudder pedal torque bearing, .032	AR	
-14	21996-00		BOOT ASSEMBLY - Rudder pedal, left	1	
	21808-00		BOOT ASSEMBLY - Rudder pedal, right	1	
-15	17203-03		BLOCK - Rudder pedal torque tube	1	

A - Used on PA-30 with serial numbers 30-2 and up, and PA-39 with serial numbers 39-1 to 39-83 inclusive.  
Z - Used on PA-39 airplanes only.

When ordering, always specify Part Number, Description and Serial Number of Aircraft

**2 A10**  
**INTENTIONALLY LEFT BLANK**

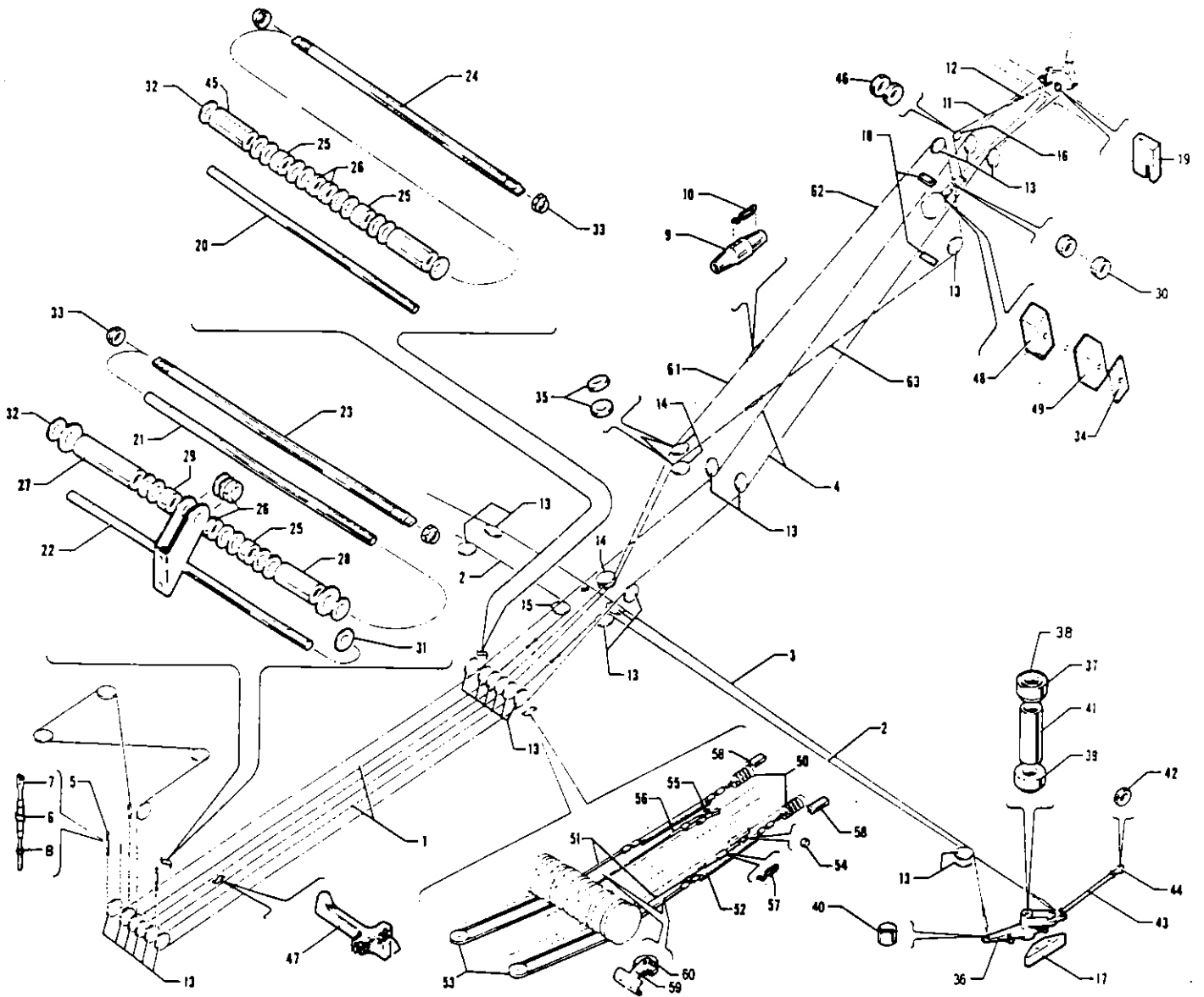

Figure 45. Control Surfaces Control Systems





Figure and Index Number	Part Number	Code	NOMENCLATURE	No. Req.	SERIAL NUMBERS AFFECTED
45-	23915	A	DRAWING - Control System Installation		30-853, 30-902 to 30-1716, 30-1718 to 30-1744 inclusive 30-1717, 30-1745 and up 39-1 to 39-83 inclusive 39-84 and up
	25401	Y	DRAWING - Control System Installation		
	26772	Y	DRAWING - Control System Installation		
	26772	Z	DRAWING - Control System Installation		
	27120	Z	DRAWING - Control System Installation		
	24017		DRAWING - Wing Installation		
-1	20943-03	Y	CABLE ASSEMBLY - Aileron control	2	30-2 to 30-1501 inclusive
	26049-02	YZ	CABLE ASSEMBLY - Aileron control	2	30-1502 and up, 39-1 and up
-2	20943-06		CABLE ASSEMBLY - Aileron, left	1	
	20943-05		CABLE ASSEMBLY - Aileron, right	1	
-3	14300-09		CABLE ASSEMBLY - Aileron balance	1	
-4	21048-00	Y	CABLE ASSEMBLY - Rudder control	2	
	21048-08	Z	CABLE ASSEMBLY - Rudder control	2	39-1 to 39-83 inclusive
	27123-00	Z	CABLE ASSEMBLY - Rudder control	2	39-84 and up
-5	19438-04	B	TURNBUCKLE ASSEMBLY	1	
-6	452 011	Z	BARREL - Turnbuckle (NAS649-B32S)	1	39-84 and up
-7	461 136	Z	FORK - Turnbuckle (NAS645-22RS)	1	39-84 and up
-8	588 378	Z	TERMINAL - Turnbuckle (MS21260-S4-LH)	1	39-84 and up
-9	452 011		BARREL - Turnbuckle (NAS649-B32S)	2	
-10	454 867		CLIP - Safety (NAS651-16S)	8	
-11	22968-00		CABLE ASSEMBLY - Stabilator control spring	1	
-12	15780-02		SPRING - Stabilator control extension	1	
-13	41001-00		PULLEY - Control cable	28	
-14	41001-03		PULLEY - Control cable	4	
-15	22042-00		BRACKET ASSEMBLY - Aileron cable pulley	1	
-16	481 621		PULLEY - (AN210-18)	1	
-17	20309-00		BLOCK - Aileron bellcrank stop	2	
-18	16771-00		BLOCK - Stabilator balance weight bumper	2	
-19	24018-00	B	BLOCK - Rudder cable rub	2	
-20	20437-04		GUARD - Pulley cable	1	
-21	20437-08		GUARD - Pulley cable	1	
-22	20437-07		GUARD - Pulley cable	1	
-23	20438-02		ROD - Pulley mounting	1	
-24	20438-04		ROD - Pulley mounting	1	
-25	14843-36		BUSHING - Control cable pulley	3	
-26	14843-37		BUSHING - Control cable pulley	4	
-27	14843-38		BUSHING - Control cable pulley	1	
-28	14843-39		BUSHING - Control cable pulley	1	
-29	14976-79		BUSHING - Control cable pulley	1	
-30	14976-84		BUSHING - Stabilator torque tube cable	2	

A - Used on PA-30 with serial numbers 30-2 to 30-852 inclusive, 30-854 to 30-901 inclusive.  
 B - Used on PA-30 with serial numbers 30-2 and up, and PA-39 with serial numbers 39-1 to 39-83 inclusive.  
 Y - Used on PA-30 airplanes only.  
 Z - Used on PA-39 airplanes only.

When ordering, always specify Part Number, Description and Serial Number of Aircraft



Figure and Index Number	Part Number	Code	NOMENCLATURE	No. Req.	SERIAL NUMBERS AFFECTED
45-31	80122-10		WASHER	1	
-32	80122-25		WASHER	30	
-33	404 889		NUT - (MS20365-524C)	4	
-34	23179-00		PLATE - Stabilator balance weight	AR	
-35	81342-96		WASHER	2	
-36	22748-00		BELLCRANK ASSEMBLY - Aileron, left	1	
	22748-01		BELLCRANK ASSEMBLY - Aileron, right	1	
-37	452 361		BEARING - (B-86)	1	
-38	452 362		BEARING - (IRA-5)	1	
-39	452 344		BEARING - (5035)	1	
-40	80022-74		BUSHING	2	
-41	80022-87		BUSHING	1	
-42	80012-94		BUSHING - Aileron control rod end	4	
-43	18316-02		ROD ASSEMBLY - Aileron control	2	
-44	452 358		BEARING - Rod end (RBE-4)	2	
-45	14843-35	Y	BUSHING - Control cable pulley	2	
	42571-09	AZ	BUSHING - Control cable pulley	2	
-46	14976-09		BUSHING - Control trim cable pulley	2	
-47	24324-00		PLATE - Control cable rub	1	
-48	25780-02	Y	WEIGHT - Stabilator balance, right	1	30-853, 30-902 to 30-1716, 30-1718 to 30-1744 inclusive
-49	25780-03	Y	WEIGHT - Stabilator balance, left	1	30-553, 30-902 to 30-1716, 30-1718 to 30-1744 inclusive
-50	24629-00	ABZ	SPRING - Control cable connector	2	
-51	24631-04	AZ	CABLE ASSEMBLY - Rudder and aileron interconnecting	2	
	24631-06	B	CABLE ASSEMBLY - Rudder and aileron interconnecting	2	
-52	487 291	ABZ	SPRING - (#180C-2 1/2)	1	
-53	481 640	AZ	PULLEY - (MS24566-1B)	2	
-54	42129-16	ABZ	BUSHING	2	
-55	459 958	ABZ	EYE - Turnbuckle (NAS646-8RS)	2	
-56	452 015	ABZ	BARREL - Turnbuckle (NAS649-B8S)	2	
-57	454 867	ABZ	CLIP - Safety (NAS651-16S)	4	
-58	757 863	AB	CLAMP - (#42A173-1)	2	
-59	27207-00	B	BRACKET - Pulley, left	1	
	27207-01	B	BRACKET - Pulley, right	1	
-60	481 640	B	PULLEY - (MS24566-1B)	2	
-61	20945-05	Y	CABLE ASSEMBLY - Stabilator control, forward	1	30-2 to 30-414 inclusive
	20945-06	Y	CABLE ASSEMBLY - Stabilator control, forward	1	30-415 to 30-1254 inclusive
	20945-03	YZ	CABLE ASSEMBLY - Stabilator control, forward	1	30-1255 and up, 39-1 and up
-62	22966-02		CABLE ASSEMBLY - Stabilator, aft, upper	1	
-63	22966-03		CABLE ASSEMBLY - Stabilator, aft, lower	1	

A - Used on PA-30 airplanes with counter-rotating right engine.

B - Used on PA-30 airplanes if Airflow Modification Kit 760 409 has been installed per Service Letter 558.

Y - Used on PA-30 airplanes only.

Z - Used on PA-39 airplanes only.

When ordering, always specify Part Number, Description and Serial Number of Aircraft

**2 A14**

**INTENTIONALLY LEFT BLANK**

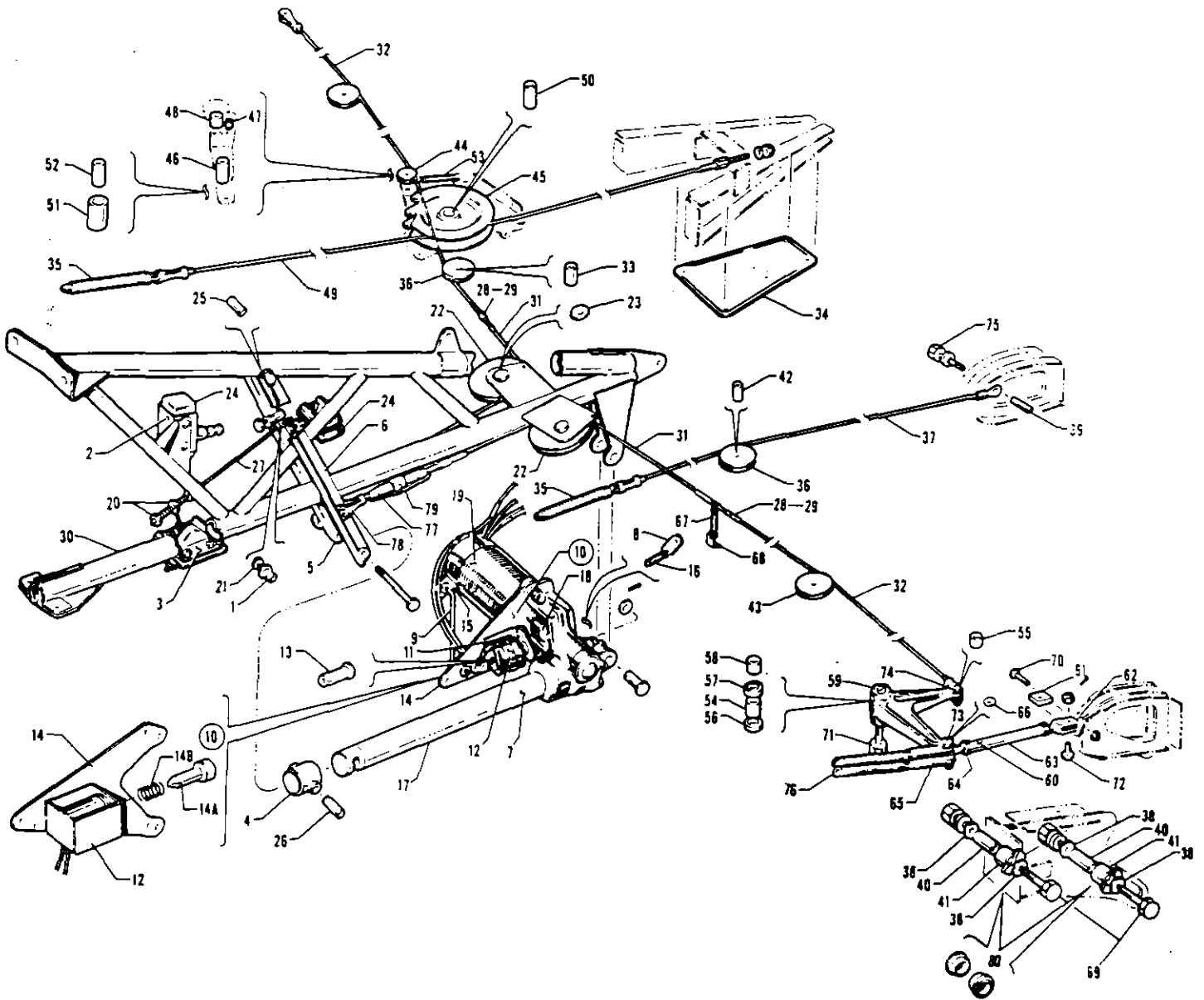

Figure 46. Flap Control Mechanism Installation



Figure and Index Number	Part Number	Code	NOMENCLATURE	No. Req.	SERIAL NUMBER AFFECTED
46-	23008	C	DRAWING - Flap Actuating Mechanism Installation		
	25351	D	DRAWING - Flap Actuating Mechanism Installation		
-1	23225-00		BUSHING	1	
-2	17807-00		GUARD - Limit switch	1	
-3	22663-00		UNIT ASSEMBLY - Flap position indicator sending	1	
-4	22688-00		BRACKET ASSEMBLY - Transmission connector	1	
-5	22694-00	C	ARM ASSEMBLY - Flap control, right	1	
	22694-03	D	ARM ASSEMBLY - Flap control, right	1	
-6	22695-00	C	ARM ASSEMBLY - Flap control, left	1	
	22695-03	D	ARM ASSEMBLY - Flap control, left	1	
-7	23013-00		TRANSMISSION ASSEMBLY - Flap control	1	
-8	21415-00	Y	LINK - Spring attachment	1	30-2 to 30-643 inclusive
-9	21418-02		ROD - Motor brake support	1	
-10	23042-00	AY	BRAKE AND ARM ASSEMBLY - (Complete)	1	30-2 to 30-643 inclusive
	24948-00	BYZ	BRAKE AND ARM ASSEMBLY - (Complete)	1	30-644 and up, 39-1 and up
-11	21401-00	AY	BRAKE ASSEMBLY - Flap motor	1	30-2 to 30-643 inclusive
-12	21419-00	AY	COIL ASSEMBLY - Flap motor brake	1	30-2 to 30-643 inclusive
	487 154	BY	SOLENOID - Flap motor brake	1	30-644 to 30-1738 inclusive
	43988-02	YZ	SOLENOID - Flap motor brake	1	30-1739 and up, 39-1 and up
-13	21404-00	AY	CORE - Motor brake coil	1	30-2 to 30-643 inclusive
-14	23046-00	AY	ARM - Spring attachment	1	30-2 to 30-643 inclusive
	24932-00	BYZ	ARM - Spring attachment	1	30-644 and up, 39-1 and up
-14a	24933-00	BYZ	PLUNGER - Brake solenoid	1	30-644 and up, 39-1 and up
-14b	83302-61	BYZ	SPRING - Solenoid plunger	1	30-644 and up, 39-1 and up
-15	60054-18		LINK - Spring attachment	1	
-16	83302-42	Y	SPRING - Coil	1	30-2 to 30-643 inclusive
-17	25720-04	E	TRANSMISSION ASSEMBLY	1	
-18	757 833		COUPLING	1	
-19	475 192		MOTOR ASSEMBLY	1	
-20	83302-50		SPRING - Coil	2	
-21	415 769		SCREW - Machine (with nyloc insert)	1	
-22	41001-03		PULLEY	2	
-23	80122-70		WASHER	4	
-24	487 805		SWITCH - Flap limit ( BZ-7RQ31T1/1PA-15)	2	
-25	14976-80		BUSHING	1	
-26	14976-81		BUSHING	1	
-27	23226-00		ROD	1	
-28	452 011	C	BARREL - (NAS649-B32S)	2	
-29	454 867	C	CLIP - (NAS651-16S)	4	

A - Not available. Secure complete brake and arm assembly. Part No. 24948-00.  
 B - Used on PA-30 with serial numbers 30-2 to 30-643 inclusive if plunger type brake and arm assembly. Part No. 24948-00 has been installed.  
 C - Used on PA-30 with serial numbers 30-2 to 30-852 inclusive, 30-854 to 30-901 inclusive.  
 D - Used on PA-30 with serial numbers 30-853, 30-902 and up, and PA-39 with serial numbers 39-1 and up.  
 E - Also order brake and arm assembly 24948-00 if existing assembly does not include a plunger type brake.  
 Y - Used on PA-30 airplanes only.  
 Z - Used on PA-39 airplanes only.

When ordering, always specify Part Number, Description and Serial Number of Aircraft

PIPER PARTS CATALOG

Figure and Index Number	Part Number	Code	NOMENCLATURE	No. Req.	SERIAL NUMBERS AFFECTED
46-30	22697-00	Y	SUPPORT ASSEMBLY - Wing, main spar, center	1	30-2 to 30-589 inclusive
	22697-07	C	SUPPORT ASSEMBLY - Wing, main spar, center	1	
	22697-10	B	SUPPORT ASSEMBLY - Wing, main spar, center	1	
-31	22886-02	A	CABLE ASSEMBLY - Control (23 3/4" L)	2	
-32	22886-03	A	CABLE ASSEMBLY - Control (57" L)	2	
	22886-04	YZ	CABLE ASSEMBLY - Control, flap mechanism to flap bellcrank (83 1/2" L)	2	30-853, 30-902 and up, 39-1 and up
-33	82732-68		BUSHING	1	
-34	23087-00		PLATE - Flap access	1	
-35	83302-40		SPRING	2	
-36	80421-00		PULLEY - Flap control cable	2	
-37	20944-08		CABLE ASSEMBLY - Flap control cable	1	
-38	19513-37	Y	WASHER	24	30-2 to 30-1679 inclusive
-39	14976-83		BUSHING	1	
-40	14976-72		BUSHING	12	
-41	14976-73	Y	BUSHING - (Steel)	12	30-2 to 30-1679 inclusive
-42	14976-82		BUSHING	1	
-43	481 623		PULLEY - (AN210-3B)	2	
-44	22793-00		PULLEY - Step lock release cable	1	
-45	22627-00		PULLEY - Step lock release cable	1	
-46	61402-32		BUSHING	1	
-47	61402-35		BUSHING	1	
-48	61402-36		BUSHING	1	
-49	23117-00		CABLE ASSEMBLY - Flap control	1	
-50	61402-29		BUSHING	1	
-51	61402-34		BUSHING	1	
-52	61402-43		BUSHING	1	
-53	83302-37		SPRING - Coil	1	
-54	14976-74		BUSHING	1	
-55	82732-98		BUSHING	1	
-56	452 344		BEARING - (#5035)	1	
-57	452 361		BEARING - (#B-86)	1	
-58	452 362		BEARING - Inner race (#1RA5)	1	
-59	22740-00		BELLCRANK - Flap	1	
-60	22855-00		ROD ASSEMBLY - Flap control	1	
-61	22852-00		* LINK - Flap control rod	1	
-62	22853-00		* CLEVIS - Flap control rod	1	
-63	22854-00		* ROD - Flap control	1	
-64	452 412		* ROD END BEARING - (#HMX-4S)	1	
-65	60054-17		LINK - Bellcrank spring	1	30-2 to 30-230 inclusive
	60054-17	D	LINK - Bellcrank spring	2	
-66	61402-44		BUSHING	2	
-67	487 291	A	SPRING	1	
-68	22878-00	A	CLIP	1	

- A - Used on PA-30 with serial numbers 30-2 to 30-852 inclusive, 30-854 to 30-901 inclusive.
- B - Used on PA-30 with serial numbers 30-853, 30-902 and up, and PA-39 with serial numbers 39-1 and up.
- C - Used on PA-30 with serial numbers 30-590 to 30-852 inclusive, 30-854 to 30-901 inclusive.
- D - Used on PA-30 with serial numbers 30-231 and up, and PA-39 with serial numbers 39-1 and up.
- Y - Used on PA-30 airplanes only.
- Z - Used on PA-39 airplanes only.

When ordering, always specify Part Number, Description and Serial Number of Aircraft

**PIPER PARTS CATALOG**

Figure and Index Number	Part Number	Code	NOMENCLATURE	No. Req.	SERIAL NUMBERS AFFECTED
46-69	401 270		BOLT - (AN3-11A)	4	
	407 564		WASHER - (AN960-10)	4	
	404 887		NUT - (MS20365-1032C)	4	
-70	400 057		BOLT - (AN3-12)	1	
	404 100		NUT - (AN310-3)	1	
	424 051		COTTER PIN - (AN380-2-2)	1	
-71	401 359		BOLT - (AN5-20A)	2	
-72	400 055		BOLT - (AN3-10)	2	
	404 100		NUT - (AN310-3)	2	
	424 051		COTTER PIN - (AN380-2-2)	2	
-73	400 008		BOLT - (AN4-13A)	2	
	404 888		NUT - (AN365-428)	2	
-74	400 673		BOLT - (AN23-11)	2	
	407 564		WASHER - (AN960-10)	2	
	404 392		NUT - (AN320-3)	2	
	424 051		COTTER PIN - (AN380-2-2)	2	
-75	401 273		BOLT - (AN3-14A)	1	
	407 564		WASHER - (AN960-10)	1	
-76	83302-54		SPRING - Bellcrank	1	30-2 to 30-230 incl.
	83302-54	B	SPRING - Bellcrank	2	
-77	452 011	A	BARREL - (NAS649-B32S)	2	
-78	461 133	A	FORK - (NAS645-32RS)	2	
-79	454 867	A	CLIP - (NAS651-16S)	4	
-80	26343-00	YZ	ROLLER - (Nylon)	24	30-1680 and up. 39-1 and up

A - Used on PA-30 with serial numbers 30-853, 30-902 and up. and PA-39 with serial numbers 39-1 and up.  
 B - Used on PA-30 with serial numbers 30-231 and up. and PA-39 with serial numbers 39-1 and up.  
 Y - Used on PA-30 airplanes only.  
 Z - Used on PA-39 airplanes only.

When ordering, always specify Part Number, Description and Serial Number of Aircraft

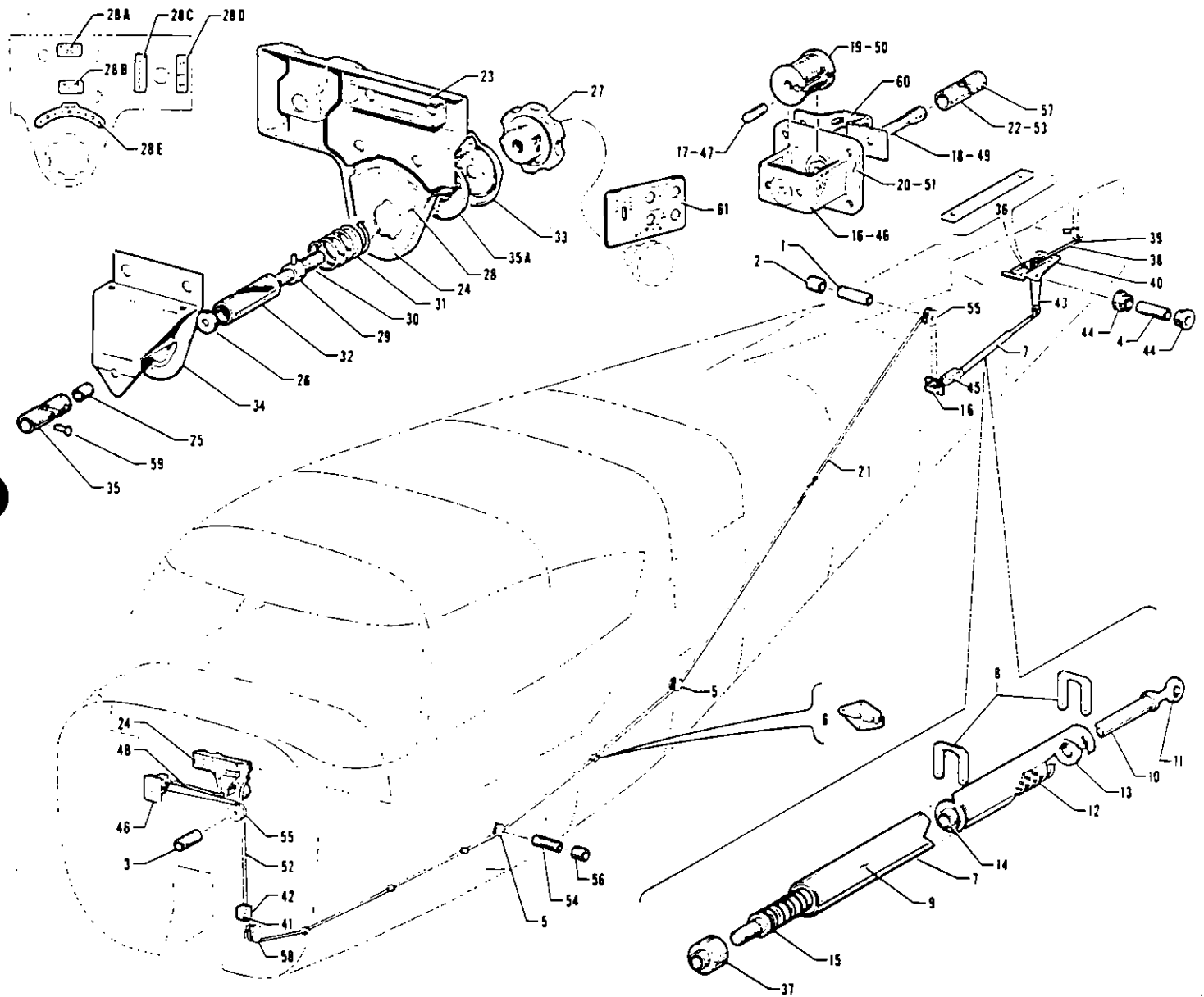

Figure 47. Rudder Trim Mechanism Installation





Figure and Index Number	Part Number	Code	NOMENCLATURE	No. Req.	SERIAL NUMBERS AFFECTED
47-	24344 26745 27128	B D Z	DRAWING - Rudder Trim Mechanism DRAWING - Rudder Trim Mechanism DRAWING - Rudder Trim Mechanism		39-84 and up
-1	14970-100		BUSHING - Trim cable pulley, inner	1	
-2	14970-99		BUSHING - Trim cable pulley, outer	1	
-3	14970-98		BUSHING - Trim cable pulley	1	
-4	14970-97		BUSHING - Bellcrank	1	
-5	20534-00		PULLEY - Rudder trim cable	4	
-6	23640-00		BLOCK - Rub	8	
-7	23951-00		TUBE ASSEMBLY - Rudder trim control	1	
-8	21383-00		CLIP - Spring retainer	2	
-9	23953-00		TUBE ASSEMBLY - Rudder trim bungee	1	
-10	21389-03		ROD ASSEMBLY - Rudder bungee connecting	1	
-11	452 383		BEARING ASSEMBLY - Rod end (24166-00)	1	
-12	24319-00		SPRING - Rudder bungee connecting rod	1	
-13	81342-98		WASHER	2	
-14	14843-95		BUSHING	2	
-15	23243-03		SCREW ASSEMBLY - Rudder trim bungee	1	
-16	24346-00		DRUM ASSEMBLY - Rudder trim aft	1	
-17	17089-00		PIN	1	
-18	24309-00		SHAFT	1	
-19	24322-00		DRUM	1	
-20	24325-00		BRACKET ASSEMBLY	1	
-21	24345-02		CABLE ASSEMBLY	1	
-22	409 132		UNIVERSAL JOINT - (MS20270-B8)	1	
-23	23957-00	B	CHANNEL - Instrument panel	1	
-24	24125-00	B	CONTROL ASSEMBLY - Rudder trim	1	
	26741-00	C	CONTROL ASSEMBLY - Rudder trim	1	
-25	14843-104		BUSHING	1	
-26	19513-61		WASHER	1	
-27	24342-00		KNOB - Rudder trim	1	
-28	23910-00	B	COVER - Rudder trim and flap switch, black	1	
	26419-02	C	COVER - Rudder trim and flap switch, black	1	
	26419-03	C	COVER - Rudder trim and flap switch, white	1	
	26419-04	C	COVER - Rudder trim and flap switch, beige	1	
-28a	24954-00	A	PLACARD - Cowl flap	1	
-28b	24955-00	A	PLACARD - Alternate air	1	
-28c	24961-00	A	PLACARD - Wing flap	1	
-28d	24962-00	A	PLACARD - Wing flap control	1	
-28e	24963-00	A	PLACARD - Rudder trim	1	

A - Used on PA-30 with serial numbers 30-594 to 30-1716 inclusive, 30-1718 to 30-1744 inclusive.  
 B - Used on PA-30 with serial numbers 30-2 to 30-1716 inclusive, 30-1718 to 30-1744 inclusive.  
 C - Used on PA-30 with serial numbers 30-1717, 30-1745 and up, and PA-39 with serial numbers 39-1 and up.  
 D - Used on PA-30 with serial numbers 30-1717, 30-1745 and up, and PA-39 with serial numbers 39-1 to 39-83 inclusive.  
 Z - Used on PA-39 airplanes only.

When ordering, always specify Part Number, Description and Serial Number of Aircraft



Figure and Index Number	Part Number	Code	NOMENCLATURE	No. Req.	SERIAL NUMBERS AFFECTED
47-29	24064-00		NUT ASSEMBLY - Rudder trim	1	
-30	24067-00		SCREW - Rudder trim control	1	
-31	24068-00		SPRING - Rudder trim control	1	
-32	24069-00		TUBE - Rudder trim indicator	1	
-33	24070-00	B	INDICATOR - Rudder trim	1	
	26739-00	A	INDICATOR - Rudder trim	1	
-34	24087-00	B	BRACKET ASSEMBLY - Rudder trim control	1	
	26371-00	A	BRACKET ASSEMBLY - Rudder trim control	1	
-35	464 132		UNIVERSAL JOINT	1	
-35a	19513-76	YZ	WASHER	1	30-120 and up, 39-1 and up
-36	24302-00		SHIM - Bellcrank bracket	1	
-37	24304-00		STOP - Rudder trim control	1	
-38	24321-00	C	ROD ASSEMBLY - Rudder trim	1	
	27124-00	Z	ROD ASSEMBLY - Rudder trim	1	39-84 and up
-39	452 383		BEARING - Rod end (24166-00)	2	
-40	24330-00	C	BRACKET ASSEMBLY	1	
	27127-00	Z	BRACKET ASSEMBLY	1	39-84 and up
-41	24337-00		PLATE - Trim cable retainer	1	
-42	24338-00		BLOCK - Trim cable retainer	1	
-43	24340-00		BELLCRANK ASSEMBLY	1	
-44	452 374		BEARING	2	
-45	23923-00		BRACKET - Rudder trim guide	1	
-46	24341-00		DRUM ASSEMBLY - Rudder trim, forward	1	
-47	17059-00		PIN	1	
-48	23165-02		TUBE	1	
-49	24309-00		SHAFT	1	
-50	24322-00		DRUM	1	
-51	24325-00		BRACKET ASSEMBLY	1	
-52	24345-03		CABLE ASSEMBLY	1	
-53	469 132		UNIVERSAL JOINT - (MS20270-88)	1	
-54	80022-96		BUSHING - Pulley	2	
-55	80421-00		PULLEY - Rudder trim	4	
-56	82732-95		BUSHING - Pulley	2	
-57	424 145		PIN - Universal joint attachment (AN392-17)	1	
	407 562		WASHER - (AN960-6)	1	
	424 051		PIN - Cotter (AN380-2-2)	1	
-58	41001-00		PULLEY - Rudder trim	2	
-59	480 705		PIN - Roll (#59-028-125-0500)	1	
-60	24320-00		BRACKET - Rudder trim guide mounting	1	
-61	26368-00	YZ	PLACARD - Rudder trim control	1	30-1717, 30-1745 and up, 39-1 and up

A - Used on PA-30 with serial numbers 30-1717, 30-1745 and up, and PA-39 with serial numbers 39-1 and up.  
 B - Used on PA-30 with serial numbers 30-2 to 30-1716 inclusive, 30-1718 to 30-1744 inclusive.  
 C - Used on PA-30 with serial numbers 30-2 and up, and PA-39 with serial numbers 39-1 to 39-83 inclusive.  
 Y - Used on PA-30 airplanes only.  
 Z - Used on PA-39 airplanes only.

When ordering, always specify Part Number, Description and Serial Number of Aircraft

**2 A22**

**INTENTIONALLY LEFT BLANK**

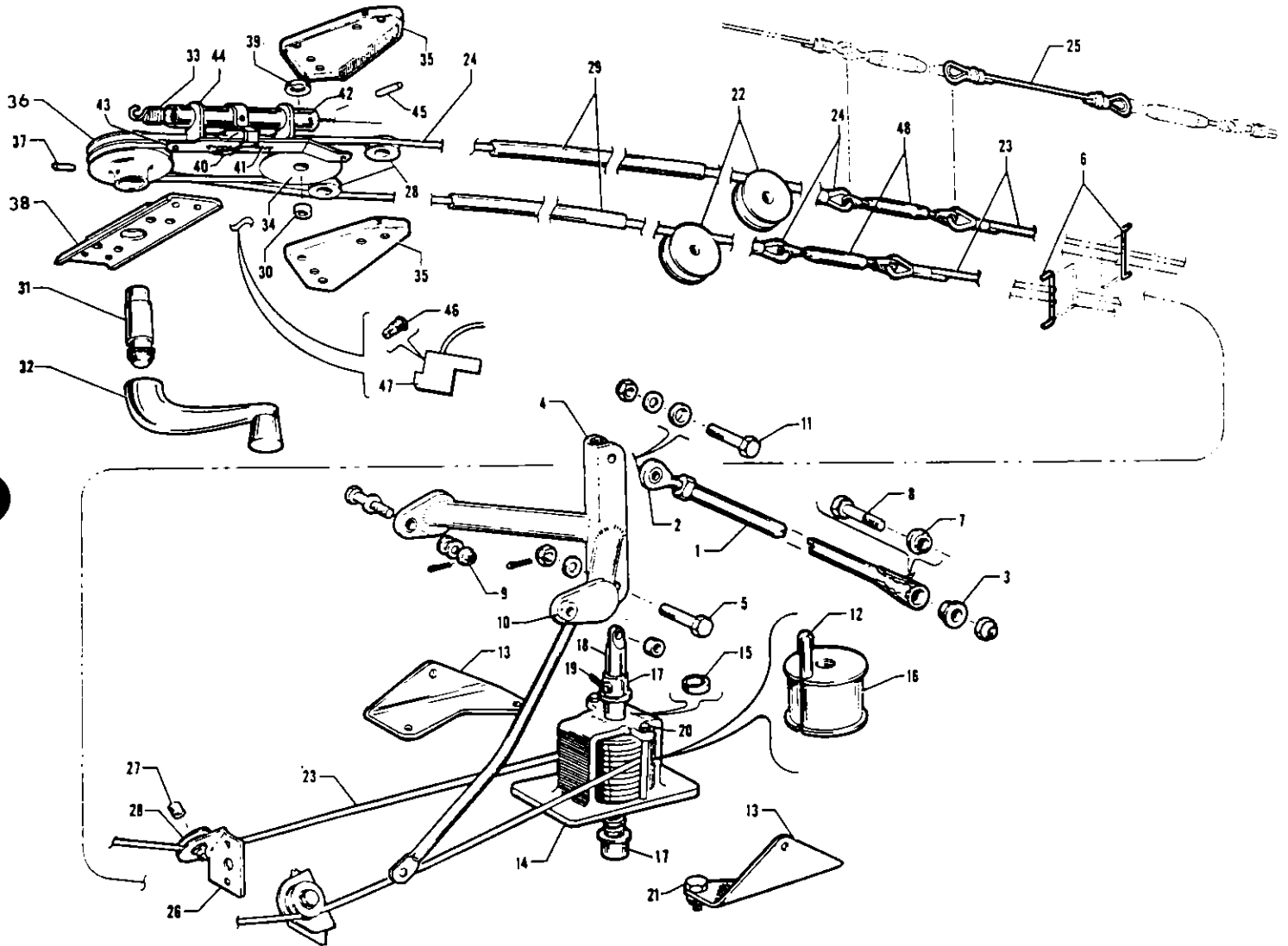

Figure 48. Stabilator Trim Mechanism Installation

PIPER PARTS CATALOG

Figure and Index Number	Part Number	Code	1234567 NOMENCLATURE	No. Req.	SERIAL NUMBERS AFFECTED
48-	23599	B	DRAWING - Stabilator Trim Mechanism Installation		
	27119	Z	DRAWING - Stabilator Trim Mechanism Installation		39-84 and up
	23915	A	DRAWING - Control System Installation		
	25401	Y	DRAWING - Control System Installation		30-853, 30-902 to 30-1718, 30-1718 to 30-1744 inclusive
	26772	YZ	DRAWING - Control System Installation		30-1717, 30-1745 and up, 39-1 to 39-83 inclusive
	27120	Z	DRAWING - Control System Installation		39-84 and up
-1	20838-00		ARM ASSEMBLY - Stabilator tab actuator	1	
-2	452 383		BEARING - Rod end	1	
-3	452 374		BEARING - Oilite	2	
-4	22887-00		BELLCRANK ASSEMBLY - Stabilator tab control	1	
-5	402 310		BOLT - (AN174-12)	1	
	407 585		WASHER - (AN960-416)	1	
	404 101		NUT - (AN310-4)	1	
	424 051		PIN - Cotter (AN380-2-2)	1	
-6	88092-66		ROD - Cable guard	2	
-7	14976-42		BUSHING	1	
-8	401 270		BOLT - (AN3-11A)	1	
	404 835		NUT (MS20364-1032C)	1	
-9	400 059		BOLT - (AN3-14)	2	
	407 564		WASHER - (AN960-10)	2	
	407 584		WASHER - (AN960-10L)	2	
	404 100		NUT - (AN310-3)	2	
	424 051		PIN - Cotter (AN380-2-2)	2	
-10	14976-52		BUSHING	2	
-11	402 311		BOLT - (AN174-12A)	1	
	407 585		WASHER - (AN960-416)	1	
	404 888		NUT - (MS20365-428C)	1	
-12	17089-00		PIN - Trim drum	1	
-13	16722-02		ANGLE - Stabilator tab control drum support, left	1	
	16722-02		ANGLE - Stabilator tab control drum support, right	1	
-14	20840-03		BRACKET ASSEMBLY - Control cable drum	1	
-15	452 376		BEARING - Oilite	2	
-16	20800-00		DRUM - Stabilator trim tab control	1	
-17	20834-04		STOP - Trim tab screw	2	
-18	22864-02		SCREW - Stabilator trim tab control	1	
-19	424 147		PIN - (AN392-21)	2	
	407 562		WASHER - (AN960-6)	2	
	424 051		PIN - Cotter (AN380-2-2)	2	
-20	400 449		BOLT - (AN3-24A)	2	
	407 564		WASHER - (AN960-10)	2	
	404 835		NUT - (MS20364-1032C)	2	
-21	401 266		BOLT - (AN3-5A)	4	
	407 564		WASHER - (AN960-10)	4	
	404 835		NUT - (MS20364-1032C)	4	

A - Used in PA-30 with serial numbers 30-2 to 30-852 inclusive, 30-854 to 30-901 inclusive.  
 B - Used on PA-30 with serial numbers 30-2 and up, and PA-39 with serial numbers 39-1 to 39-83 inclusive.  
 Y - Used on PA-30 airplanes only.  
 Z - Used on PA-39 airplanes only.

When ordering, always specify Part Number, Description and Serial Number of Aircraft



Figure and Index Number	Part Number	Code	NOMENCLATURE	No. Req.	SERIAL NUMBERS AFFECTED
48-22	431 621	C	PULLEY - (AN210-1B)	2	30-853, 30-902 and up, 39-1 and up
	20534-00	YZ	PULLEY - Stabilator trim	2	
-23	20946-00		CABLE ASSEMBLY - Stabilator trim tab control, rear	1	
-24	21093-02	B	CABLE ASSEMBLY - Stabilator trim tab control, front	1	
-25	14300-30	A	CABLE ASSEMBLY - Stabilator trim tab control	1	
-26	23452-00		BRACKET - Trim cable pulley, left	1	
	23452-01		BRACKET - Trim cable pulley, right	1	
-27	14843-34		BUSHING	2	
-28	20534-00		PULLEY	4	
-29	23954-00		TUBE - Cable guide	3	
-30	80012-04		BUSHING	1	
-31	20408-00		STEM - Crank handle	1	
-32	464 023		HANDLE ASSEMBLY - Stabilator trim crank	1	
-33	42841-00		SPRING - Stabilator indicator return	1	
-34	80421-00		PULLEY	1	
-35	20903-00	Y	BRACKET - Stabilator trim pulley	2	30-2 to 30-445 inclusive 30-449 and up, 39-1 and up
	24813-00	YZ	BRACKET - Stabilator trim pulley	2	
-36	20907-00		PULLEY - Stabilator trim crank (aluminum)	1	
	25048-02		PULLEY - Stabilator trim crank (plastic)	1	
-37	480 682		PIN - Roll (#59-022-094-0750)	1	
	480 707	A	PIN - Roll (#59-022-094-1000)	1	
-38	20905-00		CHANNEL ASSEMBLY - Trim crank lower support	1	
-39	80122-18		WASHER - Stabilator trim pulley	1	
-40	24026-00		INDICATOR - Stabilator trim	1	
-41	24027-00		PLACARD - Stabilator trim indicator	1	
-42	24025-00	Y	TUBE - Stabilator indicator	1	30-2 to 30-635 inclusive 30-639 and up, 39-1 and up
	24025-02	YZ	TUBE - Stabilator indicator	1	
-43	24024-00	Y	BRACKET - Stabilator indicator	1	30-2 to 30-635 inclusive 30-639 and up, 39-1 and up
	24024-02	YZ	BRACKET - Stabilator indicator	1	
-44	24023-00	Y	BRACKET - Stabilator indicator tube	1	30-2 to 30-635 inclusive 30-639 and up, 39-1 and up
	24023-02	YZ	BRACKET - Stabilator indicator tube	1	
-45	480 706		PIN - Roll (#59-022-094-0500)	1	
-46	472 025	Y	BULB - Indicator (#327-28V)	1	30-796 to 30-1101 inclusive 30-1102 and up, 39-1 and up
	472 054	YZ	BULB - Indicator (#330-14V)	1	
-47	484 308	YZ	RECEPTACLE - Indicator bulb (#GB-5952-3LH-C-14)	1	30-797 and up, 39-1 and up
-48	452 019		BARREL - Turnbuckle (AN155-5S)	2	

A - Used when Electric Trim is installed.  
 B - If Electric Trim is installed and 6 3/4" splice cable is not installed, order Part No. 14300-30 also.  
 C - Used on PA-30 with serial numbers 30-2 to 30-852 inclusive, 30-854 to 30-901 inclusive.  
 Y - Used on PA-30 airplanes only.  
 Z - Used on PA-39 airplanes only.

When ordering, always specify Part Number, Description and Serial Number of Aircraft

**2 B2**  
**INTENTIONALLY LEFT BLANK**

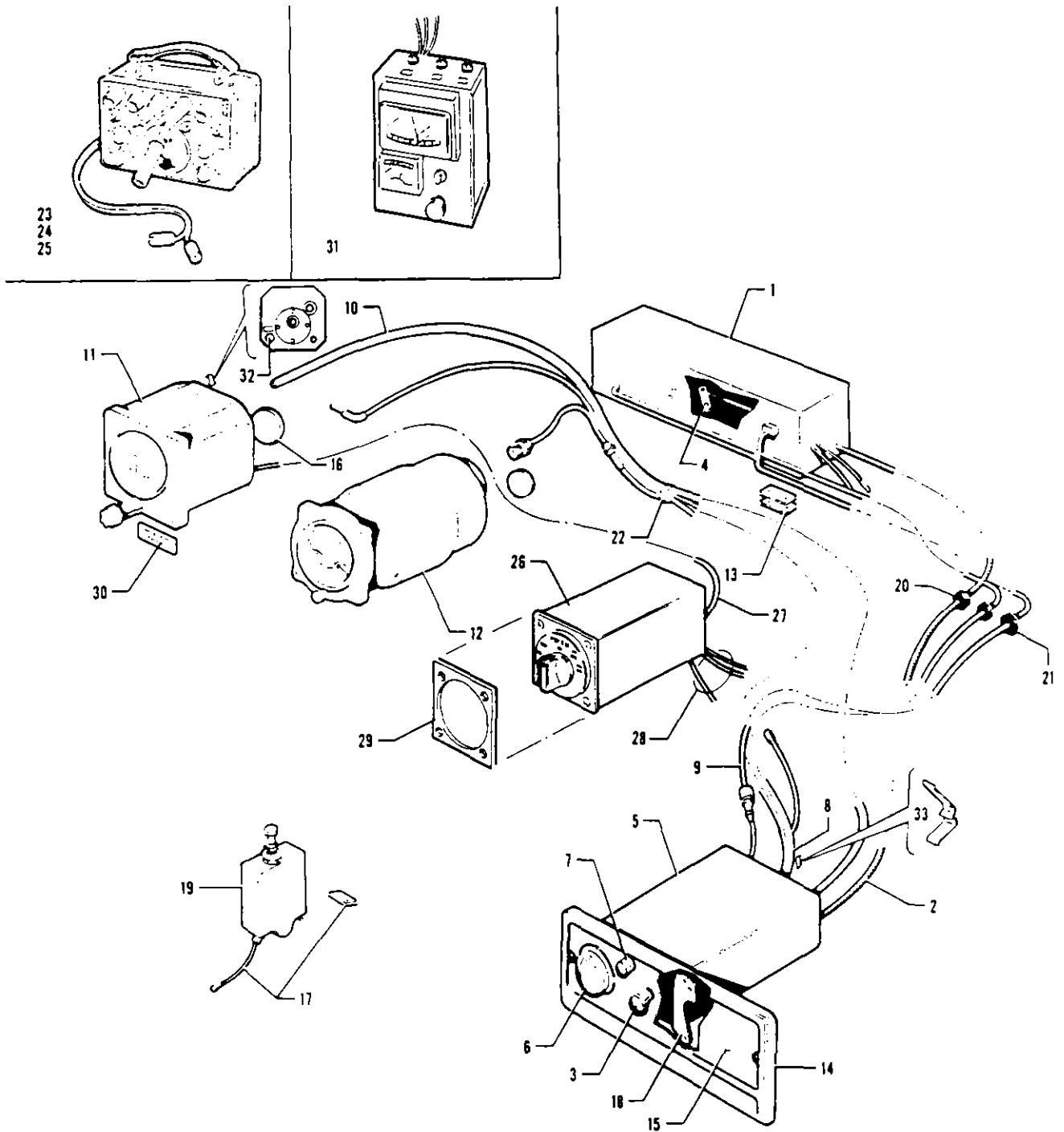

Figure 49. AutoControl II installation



PIPER PARTS CATALOG

Figure and Index Number	Part Number	Code	NOMENCLATURE	No. Req.	SERIAL NUMBERS AFFECTED
			1234567		
49-	24250 31668 31669	E F	DRAWING - AutoControl II Installation DRAWING - AutoControl II Schematic DRAWING - AutoControl II Schematic		
-1	753 634		MOTOR ASSEMBLY - Roll servo (1X221-E-CO)	1	
-2	753 870		CABLE ASSEMBLY - Engage control (30A139-34)	1	
-3	756 716		KNOB - Engage control cable (36S92)	1	
-4	752 333		LEVER - Engage (30A-83)	1	
-5	753 877	G	CONSOLE - Amplifier assembly (1X214E)	1	
	751 282	H	CONSOLE - Amplifier assembly (1X214E-3)	1	
-6	754 366		KNOB - Turn and trim (36A37)	1	
-7	756 720		BUTTON - Heading lock (36S93)	1	
-8	751 954		HARNES ASSEMBLY - (30B116-1)	1	
-9	24233-00		CABLE ASSEMBLY - Servo motor	1	
-10	753 036	G	HOSE - Air, amplifier to directional gyro (47A147-24)	1	
-11	550 840	CJ	INSTRUMENT - Directional gyro (30987-02)	1	
	550 643	DJ	INSTRUMENT - Directional gyro (31058-02)	1	
	550 626	E	INSTRUMENT - Directional gyro (31324-00) (3 inch)	1	30-2 to 30-971 inclusive
	550 644	F	INSTRUMENT - Directional gyro (31324-02) (3 inch)	1	30-2 to 30-971 inclusive
	550 779	E	INSTRUMENT - Directional gyro (32169-00) (3 inch)	1	30-972 and up
	550 778	F	INSTRUMENT - Directional gyro (32168-00) (3 inch)	1	30-972 and up
-12	550 642	J	INSTRUMENT - Gyro horizon (31053-02)	1	
	550 645		INSTRUMENT - Gyro horizon (31694-00) (3 inch)	1	30-2 to 30-971 inclusive
	550 777		INSTRUMENT - Gyro horizon (32167-00) (3 inch)	1	30-972 and up
-13	21782-00		PLATE - Chafing	4	
-14	24197-02	C	PANEL ASSEMBLY - Instrument panel cover	1	
	24197-04	D	PANEL ASSEMBLY - Instrument panel cover	1	
-15	23546-00	C	PLACARD - Operation	1	
	24991-00	D	PLACARD - Operation	1	
-16	755 825		PAD - Gyro instrument filter (not used on 3 inch gyros)	AR	
-17	20847-98	A	WIRE ASSEMBLY	1	
	22856-02	B	BAR - Bus	1	
-18	31045-00		BRACKET - Console mounting, left	1	
	31045-01		BRACKET - Console mounting, right	1	
-19	454 664		CIRCUIT PROTECTOR - (111-203-102)	1	
-20	434 128		GROMMET - (AN931-4-7)	2	
-21	434 127		GROMMET - (AN931-3-10)	1	
-22	487 608		STRAP ASSEMBLY - Cable support	2	
-23	751 412		TEST EQUIPMENT	1	
-24	756 737		ADAPTER - Test kit (66A44)	1	
-25	753 880		CABLE - Test (30B116-1-T)	1	

A - Used when radios are installed.  
 B - Used when radios are not installed.  
 C - Used on AutoControl with "O" heading.  
 D - Used on AutoControl with course selector.  
 E - Used when Omni Coupler is not installed.  
 F - Used when Omni Coupler is installed.  
 G - Used when Central Air Filter is not installed.  
 H - Used when Central Air Filter is installed.  
 J - No longer available.

When ordering, always specify Part Number, Description and Serial Number of Aircraft



Figure and Index Number	Part Number	Code	NOMENCLATURE	No. Req.	SERIAL NUMBERS AFFECTED
49-26	31071-00		COUPLER ASSEMBLY - Omni (1C292)	1	
-27	753 932	B	CABLE ASSEMBLY - Omni coupler (306152)	1	
-28	25008-00	B	CABLE ASSEMBLY - Omni coupler	1	
-29	25130-00	B	PLATE - Omni coupler spacer	1	
-30	30279-00	A	PLACARD - Directional gyro operation	1	
-31	750 873		KIT - Test. omni coupler	1	
-32	751 272	B	ADAPTER - Directional gyro	1	
-33	750 257		SPRING - Retainer	1	

A - Used on AutoControl with course selector.  
B - Used when Omni Coupler is installed.

When ordering, always specify Part Number, Description and Serial Number of Aircraft

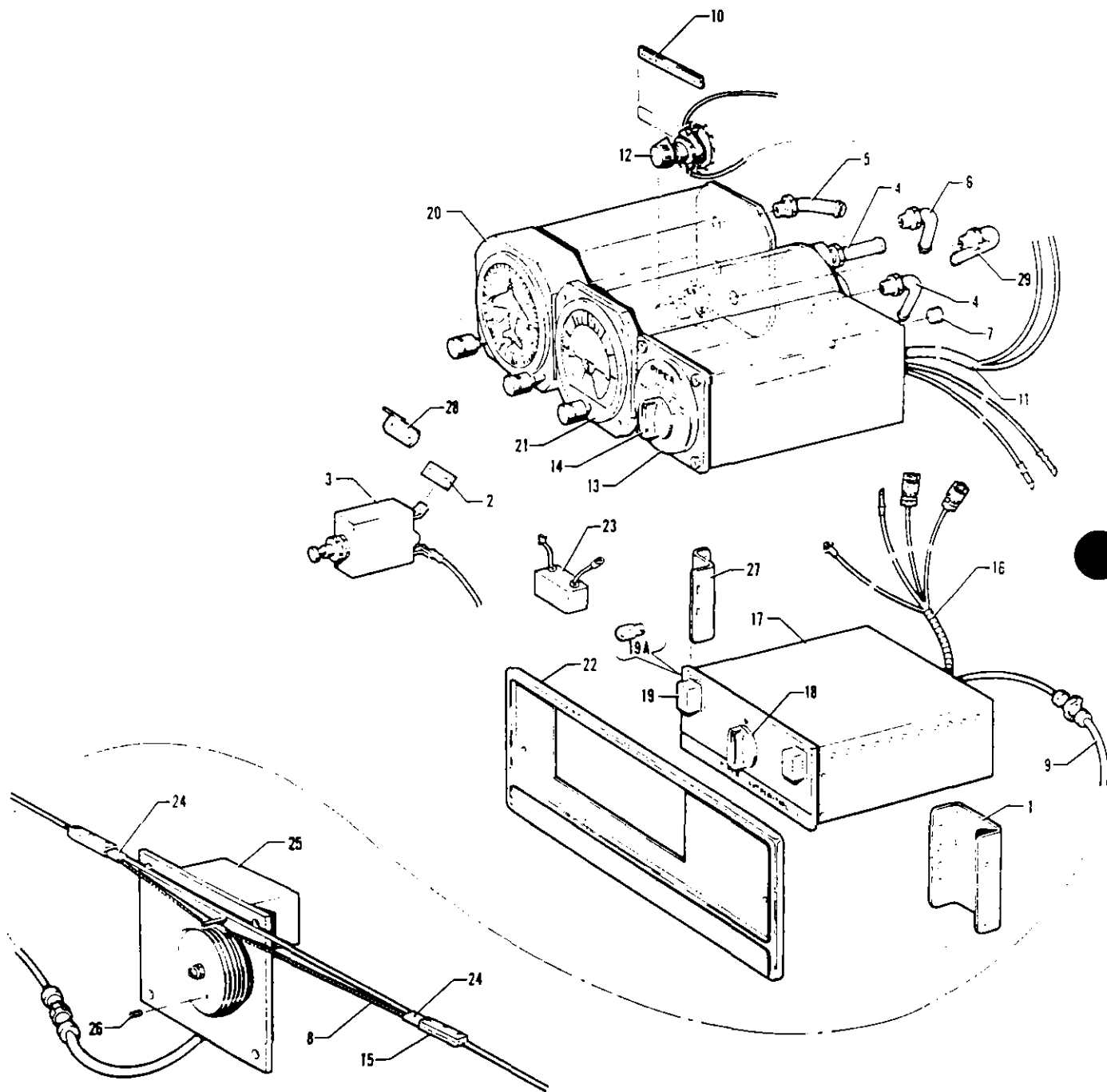

Figure 50. AutoControl III Installation



Figure and Index Number	Part Number	Code	NOMENCLATURE	No. Req.	SERIAL NUMBERS AFFECTED
50-	25676	A	DRAWING - AutoControl III Installation		
	26733	B	DRAWING - AutoControl III Installation		
-1	25673-00	A	BRACKET - AutoControl console	1	
	26761-00	B	BRACKET - AutoControl console	1	
-2	31506-02		BAR - Bus	2	
-3	454 656		PROTECTOR - Circuit (109-205-102)	1	
-4	451 939	A	ADAPTER - ( 1K10-4-6)	2	
	476 678	B	NIPPLE - (AN816-6)	2	
-5	558 913	A	ELBOW - ( 1K9-4-6)	1	
	558 937	B	ELBOW - ( 1K46-1)	1	
-6	458 948	A	ELBOW - ( 1K1-2-4)	1	
	24712-02	B	PLUG - Pipe (581 212)	1	
-7	24712-02	A	PLUG - Pipe (581 212)	1	
	558 937	B	ELBOW - ( 1K46-1)	1	
-8	25960-02		CABLE ASSEMBLY - Bridle	1	
-9	32203-02		CABLE ASSEMBLY - Servo extension	1	
-10	25743-00	A	PLACARD - Omni coupler (581 290)	1	
-11	25716-00	A	HARNESS ASSEMBLY - Omni coupler	1	
	32763-02	B	HARNESS ASSEMBLY - Omni coupler	1	
-12	42038-02	A	SWITCH - Transmitter selector (487 928)	1	
	32550-00	B	SWITCH - Transmitter selector (487 942)	1	
-13	551 114		COUPLER ASSEMBLY - Omni (25690-00)	1	
-14	757 052		KNOB - (36A98)	1	
-15	753 981		CLAMP ASSEMBLY - Bridle cable (42A173)	2	
-16	751 987		HARNESS ASSEMBLY - Amplifier (25662-00)	1	
-17	751 283		CONSOLE ASSEMBLY - AutoControl III (1C338 S/N 1 to 10000 inclusive)	1	
-18	757 052		KNOB - (36A98)	1	
-19	757 581		SWITCH - Engage (40A22-4)	2	
-19a	753 496		BULB - Console (65S28)	2	
-20	550 778		INSTRUMENT - Directional gyro (32168-00) (3 inch)	1	
-21	755 444		INDICATOR - Attitude gyro	1	
-22	23545-02	A	PANEL - Instrument panel cover	1	
-23	754 807		FILTER - Noise reducing (1A479)	1	
-24	26100-00		SLEEVE - Safety	2	
-25	753 721	A	SERVO ASSEMBLY - (1D363)	1	
	43909-04	B	SERVO ASSEMBLY - (1C363-1-161R)	1	
-26	757 579		SET SCREW - Capstan (3S326)	1	
-27	26762-00	B	BRACKET - AutoControl console	1	
-28	26789-00	B	BAR - Bus	1	
-29	451 939	A	ADAPTER - ( 1K10-4-6)	1	
	451 862	B	ADAPTER - (AN840-4)	1	

A - Used on PA-30 with serial numbers 30-1255 to 30-1716 inclusive, 30-1718 to 30-1744 inclusive.  
 B - Used on PA-30 with serial numbers 30-1717, 30-1745 and up, and PA-39 with serial numbers 39-1 and up.

When ordering, always specify Part Number, Description and Serial Number of Aircraft

PIPER PARTS CATALOG

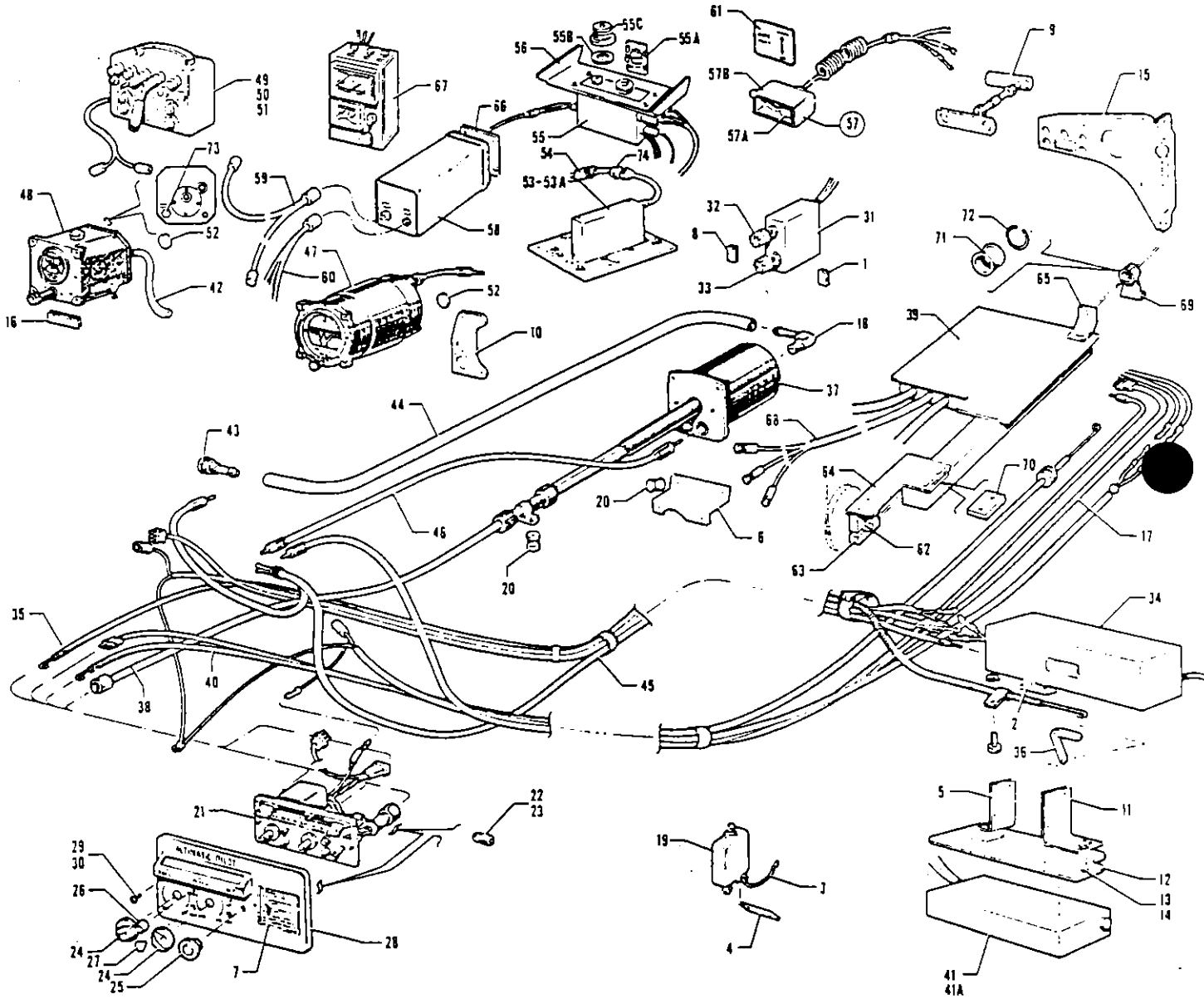

Figure 51. AltiMatic II Installation



Figure and Index Number	Part Number	Code	NOMENCLATURE	No. Req	SERIAL NUMBERS AFFECTED
51-	24240	A	DRAWING - AltiMatic II Installation		30-2 to 30-548 inclusive
	25001		DRAWING - AltiMatic II Installation		30-549 and up
	23674	A	DRAWING - AltiMatic II Schematic		30-2 to 30-548 inclusive
	31666	B	DRAWING - AltiMatic II Schematic		30-549 and up
	31667	C	DRAWING - AltiMatic II Schematic		30-549 and up
-1	19885-00		PLACARD - Altitude hold	1	
-2	21782-00		PLATE - Chafing	4	
-3	20647-98	A	WIRE ASSEMBLY	1	
-4	22856-02	B	BAR - Bus	1	
-5	24239-00		BRACKET - Amplifier mounting	1	
-6	24232-00		BRACKET - Altitude selector mounting	1	
-7	30282-00		PLACARD - Operating instructions	1	
-8	22546-00	D	PLACARD - Pitch rate, up and down	1	
	22546-02	E	PLACARD - Pitch rate, up and down	1	
-9	23148-00		BRACKET ASSEMBLY - Pitch servo support	1	30-2 to 30-548 inclusive
-10	23670-00	D	BRACKET - Control assembly mounting	1	
-11	24238-00		BRACKET ASSEMBLY - Amplifier mounting	1	
-12	24241-00		PLATE ASSEMBLY - Amplifier mounting	1	
-13	494 060		WASHER - (=2600-LW)	1	
-14	487 657		STUD - (=2600-6W)	1	
-15	23728-00		BRACKET - Pitch servo mounting	2	30-2 to 30-548 inclusive
-16	30279-00	D	PLACARD - Heading selector	1	
-17	24233-00		CABLE ASSEMBLY - Motor servo roll	1	
-18	458 929		ELBOW - (AN842-4D)	1	
-19	454 656		CIRCUIT PROTECTOR - (=2305)	1	
-20	475 130		MOUNTING - Shock (=323-B)	3	
-21	753 868		CONSOLE ASSEMBLY - (1X227-E) Less face plate	1	
-22	751 4e0		BULB - Effort light	2	
-23	751 461		BULB - Console light	2	
-24	754 36e		KNOB - Engage (36A77)	2	
-25	754 36s		KNOB - Altitude selector (36A54)	1	
-26	754 370		KNOB - Calibration (36A75)	1	
-27	754 369		KNOB - Dimmer (36A76)	1	
-28	755 814		PLATE - Face (13B111)	1	
-29	756 14e		SCREW - (3S131B)	2	
-30	752 190		WASHER - (4S88B)	2	
-31	751 240		CONTROL ASSEMBLY - (1X246)	1	
-32	754 364		KNOB - Trim roll (36A39)	1	
-33	754 365		KNOB - Trim pitch (36A73)	1	
-34	753 634		ROLL SERVO ASSEMBLY - (1X221E-C) (less engage cable and lever)	1	
-35	753 872		CABLE - Engage (30A72-32)	1	
-36	752 334		LEVER - Engage	1	

A - Secure drawings for serial numbers 30-549 and up if Kit 756 829, 756 842, 756 843, 756 844, 756 845 or 756 846 has been installed.  
 B - Used when Omni Coupler is installed.  
 C - Used when Omni Coupler is not installed.  
 D - Used when 3 inch gyros are not installed.  
 E - Used when 3 inch gyros are installed.

When ordering, always specify Part Number, Description and Serial Number of Aircraft



Figure and Index Number	Part Number	Code	NOMENCLATURE	No. Req.	SERIAL NUMBERS AFFECTED
51-37	551 131		ALTITUDE SELECTOR - (1X225)	1	
-38	756 125		CABLE - Altitude selector (81A8-19C)	1	
-39	753 633		PITCH SERVO ASSEMBLY - (1X222-C1)	1	30-2 to 30-548 inclusive
	753 678		PITCH SERVO ASSEMBLY - (1X312-C)	1	30-549 and up
-40	753 843		CABLE - Engage (30A72-58)	1	
-41	751 239	C	AMPLIFIER - (1X247)	1	30-2 to 30-548 inclusive
	751 263	D	AMPLIFIER - (1D293)	1	30-549 and up
-41a	753 916	D	COVER - Louvered. amplifier	1	30-549 and up
-42	753 035		TUBING - Air (47S147-14)	1	30-2 to 30-548 inclusive
-43	755 833		STATIC PORT ASSEMBLY - (43A97)	1	
-44	753 036		TUBING - (47S147-36)	1	
-45	751 952		HARNESS ASSEMBLY - (30D132)	1	
-46	753 841		CABLE - Altitude selector (30A79)	1	
-47	550 641	J	INSTRUMENT - Gyro horizon (30997-02)	1	30-2 to 30-971 inclusive
	550 625		INSTRUMENT - Gyro horizon (31323-00) (3 inch)	1	30-2 to 30-971 inclusive
	550 776		INSTRUMENT - Gyro horizon (32166-00) (3 inch)	1	30-972 and up
-48	550 643	AJ	INSTRUMENT - Directional gyro (31058-02)	1	
	550 626	A	INSTRUMENT - Directional gyro (31324-00) (3 inch)	1	30-2 to 30-971 inclusive
	550 644	B	INSTRUMENT - Directional gyro (31324-02) (3 inch)	1	30-2 to 30-971 inclusive
	550 779	A	INSTRUMENT - Directional gyro (32169-00) (3 inch)	1	30-972 and up
	550 778	B	INSTRUMENT - Directional gyro (32168-00) (3 inch)	1	30-972 and up
-49	756 706		ADAPTER - Test kit (66B58)	1	
-50	753 873		CABLE - Test (30D131T)	1	
-51	751 412		TEST EQUIPMENT	1	
-52	755 825		PAD - Gyro instrument filter (not used on 3 inch gyros)	AR	
-53	756 198	EF	SENSOR ASSEMBLY - Pitch trim (1D310-124)	1	
	756 255	G	SENSOR ASSEMBLY - Pitch trim (1D310-124-1)	1	
	756 248	H	SENSOR ASSEMBLY - Pitch trim (1C365-152)	1	30-853, 30-902 and up
-53a	751 277		AMPLIFIER - Pitch trim sensor (1B383) (used with pitch trim sensor =1D310-124-1)	1	

- A - Used when Omni Coupler is not installed.
- B - Used when Omni Coupler is installed.
- C - If Kit 756 842 or 756 843 has been installed, order Part No. 751 263.
- D - Used on PA-30 with serial numbers 30-2 to 30-548 inclusive if Kit 756 842 or 756 843 has been installed.
- E - Used on PA-30 with serial numbers 30-2 to 30-852 inclusive, 30-854 to 30-901 inclusive.
- F - Order Part No. 756 255 if Kit 756 974 has been installed.
- G - Used on PA-30 with serial numbers 30-2 to 30-852 inclusive, 30-854 to 30-901 inclusive if Kit 756 974 has been installed.
- H - Used on PA-30 with serial numbers 30-2 to 30-852 inclusive, 30-854 to 30-901 inclusive if Pitch Trim Sensor Assembly =1C365-152 has been installed.
- J - No longer available.

When ordering, always specify Part Number, Description and Serial Number of Aircraft

PIPER PARTS CATALOG

Figure and Index Number	Part Number	Code	NOMENCLATURE	No. Req.	SERIAL NUMBERS AFFECTED
51-54	24805-00	AD	CABLE ASSEMBLY - Trim sensor	1	
	32005-03	C	CABLE ASSEMBLY - Trim sensor	1	30-853, 30-902 and up
-55	25037-00	AD	SERVO ASSEMBLY - Electric trim (Piper)	1	
	753 693	C	SERVO ASSEMBLY - Electric trim (1D345) (Mitchell)	1	30-853, 30-902 and up
-55a	751 276	C	* AMPLIFIER ASSEMBLY - Trim servo (1B346)	1	30-853, 30-902 and up
-55b	494 159	ADV	* WASHER - Servo friction (24696-00)	1	
-55c	581 126	ADV	* PLATE - Servo clutch, outer (24695-00)	1	
-56	24624-00		BRACKET ASSEMBLY - Trim servo mounting	1	
-57	31893-02	AD	CORD AND SWITCH ASSEMBLY - Electric trim (toggle type)	1	
	32008-03	C	CORD AND SWITCH ASSEMBLY - Electric trim (toggle type)	1	30-853, 30-902 and up
-57a	487 859	AD	* SWITCH - (#8868-K2)	1	
	487 873	C	* SWITCH - (#8869-K2)	1	30-853, 30-902 and up
-57b	24641-00		* HOOD ASSEMBLY - Connector	1	
-58	31671-00		COUPLER ASSEMBLY - Omni coupler (1C292)	1	
-59	753 932	B	CABLE ASSEMBLY - Omni coupler (30B152)	1	
-60	25008-00	B	CABLE ASSEMBLY - Omni coupler	1	
-61	25596-00		PLACARD - Electric trim switch	1	
-62	24799-02		BLOCK - Pitch servo mounting	1	
-63	24799-03		BLOCK - Pitch servo mounting	1	
-64	24801-00		BRACKET - Pitch servo mounting	1	
-65	24802-00		BRACKET - Pitch servo mounting	1	
-66	25130-00	B	PLATE - Omni coupler spacer	1	
-67	756 873		KIT - Test. Omni coupler	1	
-68	31890-03	AD	CABLE ASSEMBLY - Trim servo	1	
	32006-03	C	CABLE ASSEMBLY - Trim servo	1	30-853, 30-902 and up
-69	25421-00		BRACKET ASSEMBLY - Fairlead	1	
-70	25422-00		BLOCK - Spacer, pitch servo bracket	1	
-71	40071-00		FAIRLEAD	2	
-72	40081-00		LOCK RING	1	
-73	751 272	B	ADAPTER - Directional gyro	1	
-74	27212-00	AE	HARNES ASSEMBLY - Pitch trim sensor (2")	1	

- A - Used on PA-30 with serial numbers 30-2 to 30-852 inclusive, 30-854 to 30-901 inclusive.
- B - Used when Omni Coupler is installed.
- C - Used on PA-30 with serial numbers 30-2 to 30-852 inclusive, 30-854 to 30-901 inclusive if Pitch Trim Sensor Assembly #1C365-152 has been installed.
- D - Used when Pitch Trim Sensor Assembly #1D310-124 or #1D310-124-1 has been installed.
- E - Used on PA-30 airplanes with counter-rotating right engine or if Airflow Modification Kit 760 409 has been installed per Service Letter 558.
- V - These parts must be ordered from Service Spares Department, Piper Aircraft Corporation, Vero Beach, Florida.

When ordering, always specify Part Number, Description and Serial Number of Aircraft



**2B12**  
INTENTIONALLY LEFT BLANK

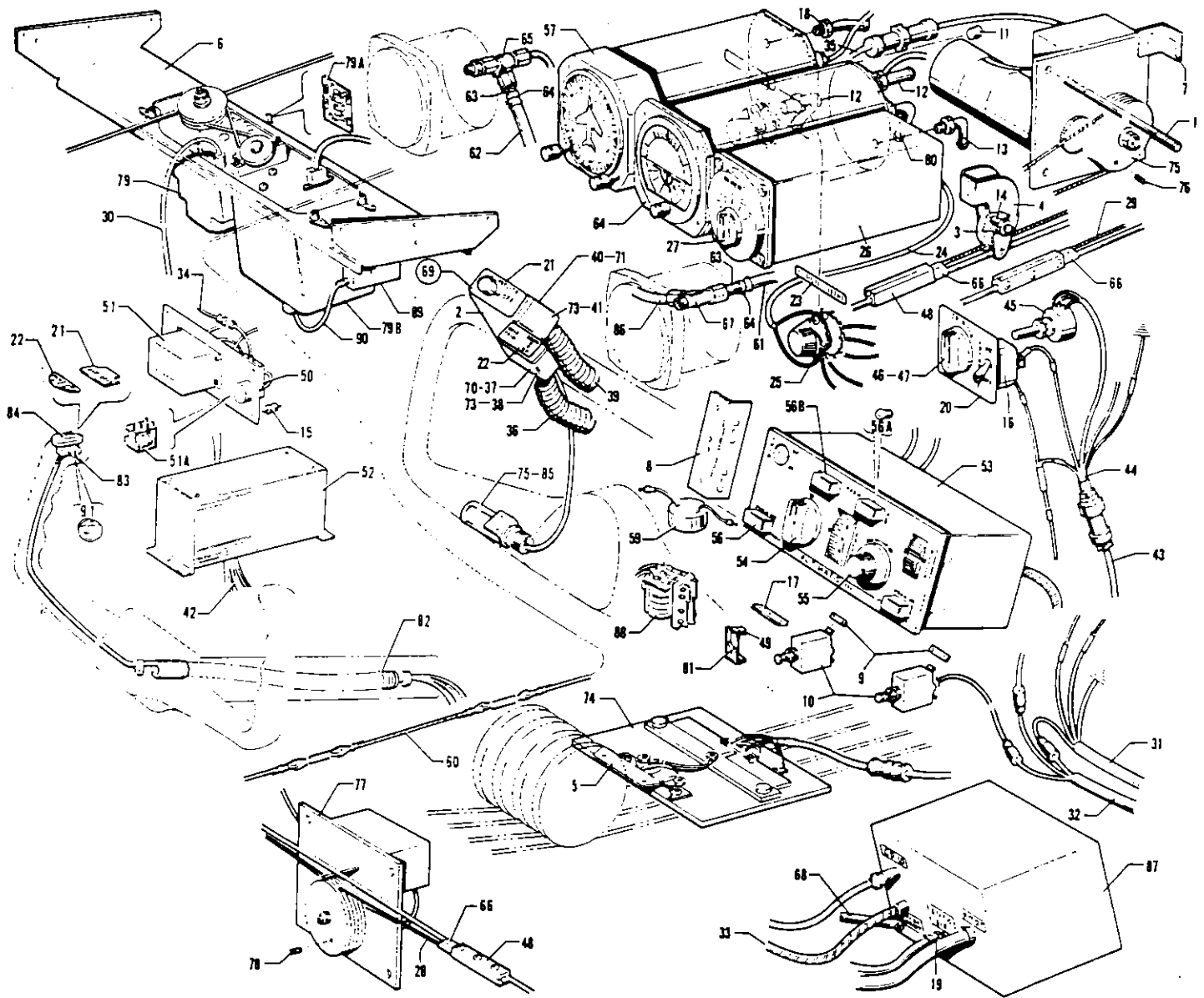

Figure 52. AltiMatic III and AltiMatic III B Installations



Figure and Index Number	Part Number	Code	NOMENCLATURE	No. Req.	SERIAL NUMBERS AFFECTED
52-	25708 26714 26884	A Y EYZ	DRAWING - AltiMatic Pilot III Installation DRAWING - AltiMatic Pilot III Installation DRAWING - AltiMatic Pilot IIIB Installation		30-1717, 30-1745 to 30-1828 30-1829 and up, 39-1 to 39-145
-1	14183-06		ROD - Pitch servo adjustment	1	
-2	32205-00	A	BRACKET - Disconnect switch	1	
-3	481 640 40071-00	A F	PULLEY - Pitch servo cable (MS24506-1B) FAIRLEAD - Pitch servo cable	1 2	
-4	25715-00 26649-00	A F	BRACKET - Pitch servo pulley BRACKET ASSEMBLY - Pitch servo fairlead	1 1	
-5	25599-00		BRACKET - Trim sensor mounting	1	
-6	24624-00 26647-00	A F	BRACKET ASSEMBLY - Servo mounting BRACKET ASSEMBLY - Servo mounting	1 1	
-7	25677-00 26648-00	A F	ANGLE - Pitch servo mounting ANGLE - Pitch servo mounting	1 1	
-8	25671-00	A	ANGLE ASSEMBLY - AltiMatic III console	1	
-9	31506-02 16439-00	A F	BAR - Bus BAR - Bus	2 2	
-10	454 656		PROTECTOR - Circuit (101-205-102)	3	
-11	24712-02		PLUG - Pipe, plated (581 212)	1	
-12	451 939 476 678	A F	ADAPTER - (1K10-4-6) NIPPLE - (AN816-6)	2 2	
-13	451 881 558 937	A F	ADAPTER - (1K10-2-4) ELBOW - (1K46-1)	1 1	
-14	14976-104 40081-00	A F	BUSHING - Pitch servo pulley LOCK RING - Pitch servo fairlead	1 1	
-15	475 130		MOUNT - Shock gyro amplifier (323B)	4	
-16	487 860 32370-13	A F	SWITCH - AutoFlite (2FA54-73) SWITCH - AutoFlite (487 956)	1 1	
-17	31506-06	F	BAR - Bus	1	
-18	558 937	F	ELBOW - (1K46-1)	1	
-19	451 857		ADAPTER - (AN840-4D)	1	
-20	25706-00	A	PLACARD - AutoFlite (581 281)	1	
-21	25707-00 43363-00 43365-00 43362-00	A B C D	PLACARD - AutoFlite (581 282) PLACARD - AutoFlite (581 374) PLACARD - AutoPilot (581 376) PLACARD - AutoPilot and boom mike (581 373)	1 1 1 1	
-22	25596-00 43360-00	A F	PLACARD - Electric trim (581 168) PLACARD - Electric trim (581 371)	1 1	
-23	25743-00	A	PLACARD - Omni coupler (581 290)	1	

A - Used on PA-30 with serial numbers 30-1255 to 30-1716 inclusive, 30-1718 to 30-1744 inclusive.  
 B - Used if AltiMatic III is installed.  
 C - Used if AltiMatic IIIB is installed.  
 D - Used if Boom Mike is installed.  
 E - Used on PA-30 with serial numbers 30-1717, 30-1745 to 30-1828 inclusive if AltiMatic IIIB is installed.  
 F - Used on PA-30 with serial numbers 30-1717, 30-1745 and up. and PA-39 with serial numbers 39-1 and up.  
 Y - Used on PA-30 airplanes only.  
 Z - Used on PA-39 airplanes only.

When ordering, always specify Part Number, Description and Serial Number of Aircraft



Figure and Index Number	Part Number	Code	NOMENCLATURE	No. Req	SERIAL NUMBERS AFFECTED
32-24	25716-00	A	HARNESS ASSEMBLY - Omni coupler	1	
	32761-02	D	HARNESS ASSEMBLY - Omni coupler	1	
-25	42038-02	A	SWITCH - Transmitter selector (487 928)	1	
	32550-00	D	SWITCH - Transmitter selector (487 942)	1	
-26	551 114		COUPLER ASSEMBLY - Omni (25690-00) (for D. C. Converter)	1	
	757 905		COUPLER ASSEMBLY - Omni (1C388P-C) (for A. C. Converter)	1	
-27	757 052		KNOB - (36A98)	1	
-28	25960-02		CABLE ASSEMBLY - Bridle, roll servo	1	
-29	25960-03		CABLE ASSEMBLY - Bridle, pitch servo	1	
-30	32005-03		CABLE ASSEMBLY - Trim sensor	1	
-31	32007-07		CABLE ASSEMBLY - Trim servo	1	
-32	32210-02	C	HARNESS ASSEMBLY - Trim servo	1	
	32210-06	Z	HARNESS ASSEMBLY - Trim servo	1	39-84 and up
-33	32212-03		CABLE - Flex, altitude selector	1	
-34	32203-04		CABLE - Extension	1	
-35	32203-06		CABLE - Extension	1	
-36	32008-03	AB	CORD ASSEMBLY - Electric trim power	1	
-37	487 873	A	SWITCH - Toggle (8869-K2)	1	
-38	24641-00	A	HOOD ASSEMBLY - Connector	1	
-39	32213-00	AB	CORD ASSEMBLY - AutoFlite disconnect switch	1	
-40	487 861	A	SWITCH - (MSP-205R)	1	
-41	24641-00	A	HOOD ASSEMBLY - Connector	1	
-42	751 989		HARNESS ASSEMBLY - AltiMatic III (25689-02)	1	
-43	751 993		HARNESS ASSEMBLY - AutoFlite (32211-02)	1	
-44	751 996	A	HARNESS ASSEMBLY - AutoFlite (32207-03) (with knob)	1	
	32207-04	D	HARNESS ASSEMBLY - AutoFlite (without knob)	1	
-45	757 296	A	POTENTIOMETER - (18A18-2)	1	
	757 297	D	POTENTIOMETER - (18A18)	1	
-46	757 052	A	KNOB - Potentiometer (36A98)	1	
-47	571 112	D	KNOB - Potentiometer (105D)	1	
-48	753 981		CLAMP ASSEMBLY - Bridle cable (42A173)	4	
-49	453 424	D	BRACKET - Narrow snap-in "F"	1	
-50	755 990		BOX - Relay switching (1B405)	1	
-51	751 278		AMPLIFIER - Gyro (1C359-1)	1	
-51a	756 052		RELAY - Gyro amplifier (80S11)	1	
-52	751 284		AMPLIFIER - (1D395)	1	

- A - Used on PA-30 with serial numbers 30-1255 to 30-1716 inclusive, 30-1718 to 30-1744 inclusive.
- B - Used if Map Light is not installed.
- C - Used on PA-30 with serial numbers 30-1255 to 30-1716 inclusive, and 30-1718 and up, and PA-39 with serial numbers 39-1 to 39-83 inclusive.
- D - Used on PA-30 with serial numbers 30-1717, 30-1745 and up, and PA-39 with serial numbers 39-1 and up.
- Z - Used on PA-39 airplanes only.

When ordering, always specify Part Number, Description and Serial Number of Aircraft



Figure and Index Number	Part Number	Code	NOMENCLATURE	No. Req.	SERIAL NUMBERS AFFECTED
52-53	757 807		CONSOLE - AltiMatic III (25688-00)	1	
	26862-00		CONSOLE - AltiMatic IIIB (1C519)	1	
-54	757 052		KNOB - Roll (36A98)	1	
-55	757 051		KNOB - Selector (36A123)	1	
-56	757 581	B	SWITCH - Engage (40A-22-4)	4	
-56a	753 496	B	BULB - Console (65S28)	4	
	758 164	C	BULB - Blue (65A56-1)	3	
-56b	758 179	C	BUTTON - Push (36S137)	3	
-57	550 778		INSTRUMENT - Directional gyro (32168-00) (3 inch)	1	
-58	550 559		INSTRUMENT - Gyro horizon (32173-02) (3 inch)	1	
-59	754 807		FILTER - Noise reducing (1A479)	1	
-60	14300-30		CABLE ASSEMBLY - Stabilator trim	1	
-61	16633-65		HOSE - Airspeed indicator	1	
-62	16333-66		HOSE - Airspeed indicator	1	
-63	25705-00	A	TUBE ASSEMBLY - Airspeed indicator	2	
	26564-00	D	TUBE ASSEMBLY - Airspeed indicator	1	
-64	454 983		CLAMP - (SAE #8)	4	
-65	488 525		TEE - Swivel (3-SW-12)	1	
-66	26100-00		SLEEVE - Safety	4	
-67	488 310		TEE - (AN826-3D)	1	
-68	25871-00	A	TUBE - Altitude selector support	1	
	26816-00	D	TUBE - Altitude selector support	1	
-69	25846-00	A	CORD ASSEMBLY - Electric trim, AutoFlite and map light	1	
-70	487 873	A	SWITCH - Toggle (8869-K2)	1	
-71	487 861	A	SWITCH - (MSP-205R)	1	
-72	472 770	A	LIGHT ASSEMBLY - Map (15-0100-2)	1	
-73	24641-00	A	HOOD ASSEMBLY - Connector	2	
-74	756 248		SENSOR ASSEMBLY - Trim (1C365-152)	1	
-75	753 721	A	SERVO ASSEMBLY - Pitch (1D363)	1	
	43909-03	Y	SERVO ASSEMBLY - Pitch (1C363-1-186P)	1	30-1717, 30-1745 and up
	43909-11	Z	SERVO ASSEMBLY - Pitch (1C508-1-296P)	1	
-76	757 579		SET SCREW - Capstan (3S326)	1	
-77	753 721	A	SERVO ASSEMBLY - Roll (1D363)	1	
	43909-04	D	SERVO ASSEMBLY - Roll (1C363-1-161R)	1	
-78	757 579		SET SCREW - Capstan (3S326)	1	
-79	753 693	A	SERVO ASSEMBLY - Trim (1D345)	1	
	757 590	D	SERVO ASSEMBLY - Trim (1C345-1)	1	
-79a	751 276	A	AMPLIFIER ASSEMBLY - Trim servo (1B346)	1	
-79b	751 301	D	AMPLIFIER ASSEMBLY - Trim servo (79C53-1)	1	
-80	451 939	A	ADAPTER - (1K10-4-6)	1	
	451 862	D	ADAPTER - (AN840-4)	1	

A - Used on PA-30 with serial numbers 30-1255 to 30-1716 inclusive, 30-1718 to 30-1744 inclusive.  
 B - Used if AltiMatic III is installed.  
 C - Used if AltiMatic IIIB is installed.  
 D - Used on PA-30 with serial numbers 30-1717, 30-1745 and up, and PA-39 with serial numbers 39-1 and up.  
 Y - Used on PA-30 airplanes only.  
 Z - Used on PA-39 airplanes only.

When ordering, always specify Part Number, Description and Serial Number of Aircraft

**PIPER PARTS CATALOG**

Figure and Index Number	Part Number	Code	NOMENCLATURE	No. Req.	SERIAL NUMBERS AFFECTED
52-81	32510-00	A	PLATE - Cover (581 445)	1	
-82	26934-00	A	CORD ASSEMBLY - (555 374)	1	
-83	487 904	A	SWITCH - AutoPilot (39-1)	1	
	487 904	C	SWITCH - AutoPilot (39-1)	1	
-84	761 039	AV	KIT - Electric trim switch replacement	1	
-85	472 770	A	LIGHT ASSEMBLY - Map (15-0100-2)	1	
-86	25705-00		TUBE ASSEMBLY - Airspeed indicator	1	
-87	757 538		ALTITUDE SELECTOR - (10391-186)	1	
-88	26838-00	B	RELAY ASSEMBLY - AutoPilot	1	
-89	756 347	Z	TRIM WARNING ASSEMBLY UNIT - (1C547)	1	39-84 and up
-90	755 202	Z	HARNES ASSEMBLY - Trim warning (30C358)	1	39-84 and up
-91	27214-00		NUT - AutoPilot switch	1	
<p>A - Used on PA-30 with serial numbers 30-1717, 30-1745 and up, and PA-39 with serial numbers 39-1 and up.                      B - Used if AltiMatic IIIB is installed.                      C - Used if Boom Mike is installed.                      V - These parts must be ordered from Service Spares Department, Piper Aircraft Corporation, Vero Beach, Florida.                      Z - Used on PA-39 airplanes only.</p>					

When ordering, always specify Part Number, Description and Serial Number of Aircraft

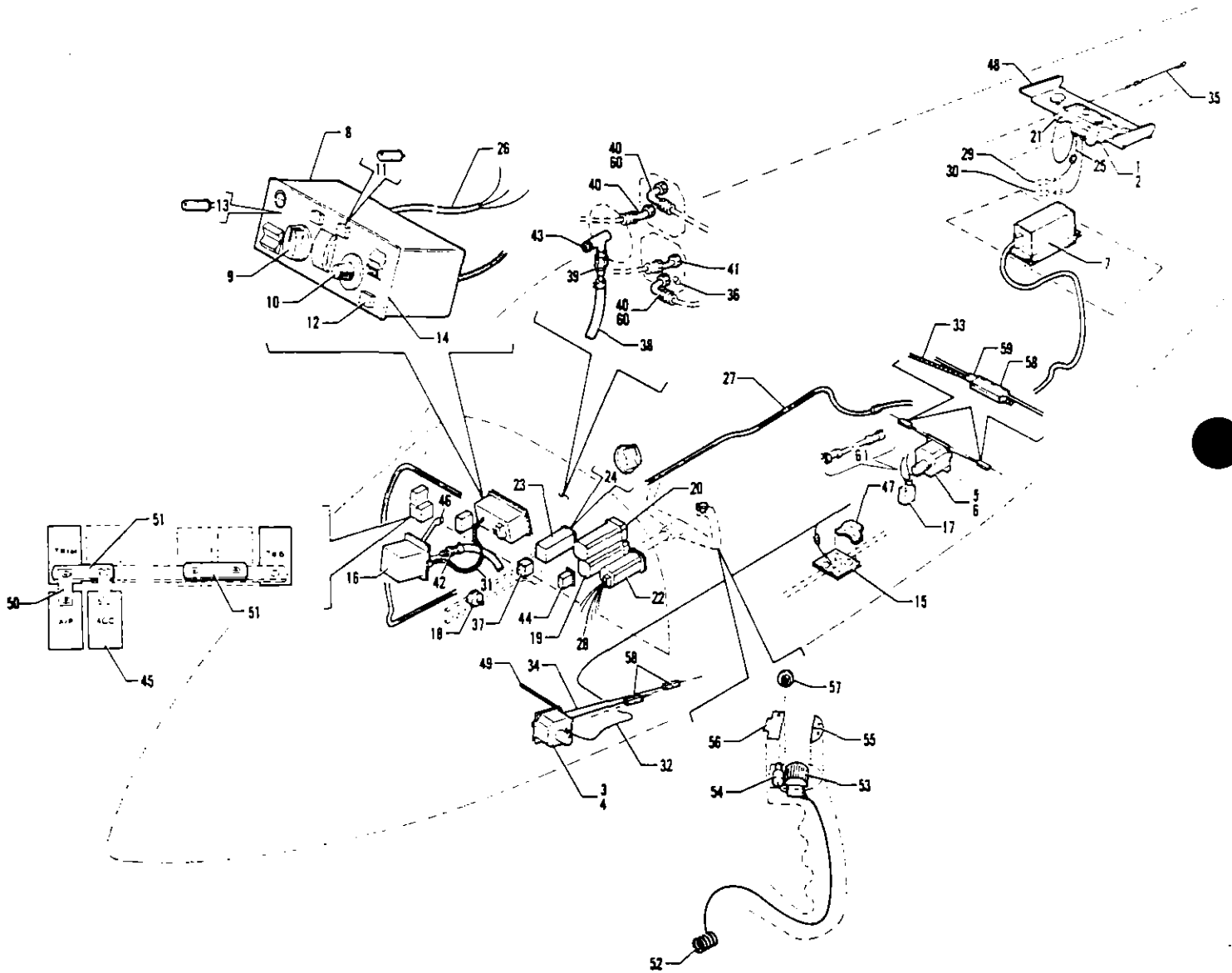

Figure 52A. AltiMatic Pilot III B-1 Installation



Figure and Index Number	Part Number	Code	NOMENCLATURE	No. Req.	SERIAL NUMBERS AFFECTED
52A-	27333		DRAWING - Altimatic Pilot III B-1 Installation		
-1	757 711		SERVO ASSEMBLY - Trim (1C345-1-186)	1	
-2	751 301		AMPLIFIER - Trim servo (79C53-1)	1	
-3	43909-11		SERVO ASSEMBLY - Pitch (1C508-1-296P)	1	
-4	757 579		SET SCREW - Capstan (36S326)	1	
-5	43909-04		SERVO ASSEMBLY - Roll (1C363-1-161R)	1	
-6	757 579		SET SCREW - Capstan (36S326)	1	
-7	751 314		AMPLIFIER - (1C515-1)	1	
-8	26882-02		CONSOLE - Altimatic III B-1 (1C519-2)	1	
-9	757 052		KNOB - Roll (36A98)	1	
-10	757 051		KNOB - Selector (36A123)	1	
-11	758 207		BULB - Blue (65A22-1)	3	
	752 317		BULB - Clear (327)	3	
-12	758 179		BOTTOM - Push (26S137)	3	
-13	753 496		BULB - Console, roll switch (65S28)	1	
-14	757 382		PLATE ASSEMBLY - Face (13B-439-1) (with four bulbs)	1	
-15	756 248		SENSOR ASSEMBLY - Trim (1C365-152)	1	
-16	44377-04		ALTITUDE SELECTOR - (1D391-2)	1	
-17	755 990		RELAY SWITCHING BOX - (1B405)	1	
-18	754 807		FILTER - Noise (1A479)	1	
-19	550 778		INSTRUMENT - Directional gyro (32168-00) (3 inch)	1	
-20	550 559		INSTRUMENT - Attitude gyro (32173-02) (3 inch)	1	
-21	756 347		TRIM WARNING ASSEMBLY UNIT - (1C547)	1	
-22	52586-02		INDICATOR ASSEMBLY - Turn and bank (550 497)	1	
-23	551 114		COUPLER ASSEMBLY - Omni (25690-00)	1	
-24	757 052		KNOB - (36A98)	1	
-25	755 202		HARNESS ASSEMBLY - Trim warning (30C358)	1	
-26	32210-06		HARNESS ASSEMBLY - Trim servo	1	
-27	25689-02		HARNESS ASSEMBLY - Altimatic III B-1	1	
-28	52588-05		HARNESS ASSEMBLY - Turn and bank (30C402)	1	
-29	32005-03		CABLE ASSEMBLY - Pitch trim sensor	1	
-30	32007-07		CABLE ASSEMBLY - Pitch trim servo	1	
-31	32212-03		CABLE ASSEMBLY - Flexible (B1A16-183)	1	
-32	32203-06		CABLE ASSEMBLY - Pitch servo extension	1	
-33	25960-02		CABLE ASSEMBLY - Bridle, roll servo	1	
-34	25960-03		CABLE ASSEMBLY - Bridle, pitch servo	1	
-35	14300-30		CABLE ASSEMBLY - Pitch trim servo extension	1	
-36	24712-02		PLUG - Pipe, plated (581 312)	1	
-37	52624-02		RELAY ASSEMBLY - AutoPilot	1	
-38	16633-65		HOSE - Static air, altitude selector	1	
-39	25705-00		TUBE ASSEMBLY - Static air, altitude selector	1	
-40	558 937		ELBOW - ( 1K46-1)	2	
-41	451 939		ADAPTER - ( 1K10-4-6)	1	
-42	451 857		ADAPTER - (AN840-4D)	1	
-43	488 310		TEE - (AN826-3D)	1	
-44	32370-13		SWITCH - Illuminated	1	
-45	454 656		CIRCUIT PROTECTOR - ( 109-205-102)	4	
-46	26816-00		TUBE - Altitude selector support	1	
-47	25599-00		BRACKET - Trim sensor mounting	1	
-48	26647-00		BRACKET ASSEMBLY - Pitch trim servo mounting	1	
-49	14183-06		ROD - Tie, control cable	1	
-50	16439-00		BAR - Bus, circuit protector	1	
-51	31506-02		BAR - Bus, circuit protector	2	

When ordering, always specify Part Number, Description and Serial Number of Aircraft



**PIPER PARTS CATALOG**

Figure and Index Number	Part Number	Code	NOMENCLATURE	No. Req.	SERIAL NUMBERS AFFECTED
52A-52	26934-00	V	CORD ASSEMBLY - Control wheel	1	
-53	761 039		KIT - Electric trim switch replacement	1	
-54	487 904		SWITCH ASSEMBLY - (#39-1)	1	
-55	43360-00		PLACARD - Control wheel ("DWN-UP")	1	
-56	43365-00		PLACARD - Control wheel ("A/P OFF")	1	
-57	27214-00		NUT - AutoPilot switch	1	
-58	753 981		CLAMP ASSEMBLY - Bridle cable (42A173)	4	
-59	26100-00		SLEEVE - Safety, control cable	4	
-60	476 678		NIPPLE - (AN816-6)	2	
-61	32203-04		CABLE - Extension, relay switch box	1	
			V	These parts must be ordered from Service Spares Department, Piper Aircraft Corporation, Vero Beach, Florida.	

When ordering, always specify Part Number, Description and Serial Number of Aircraft

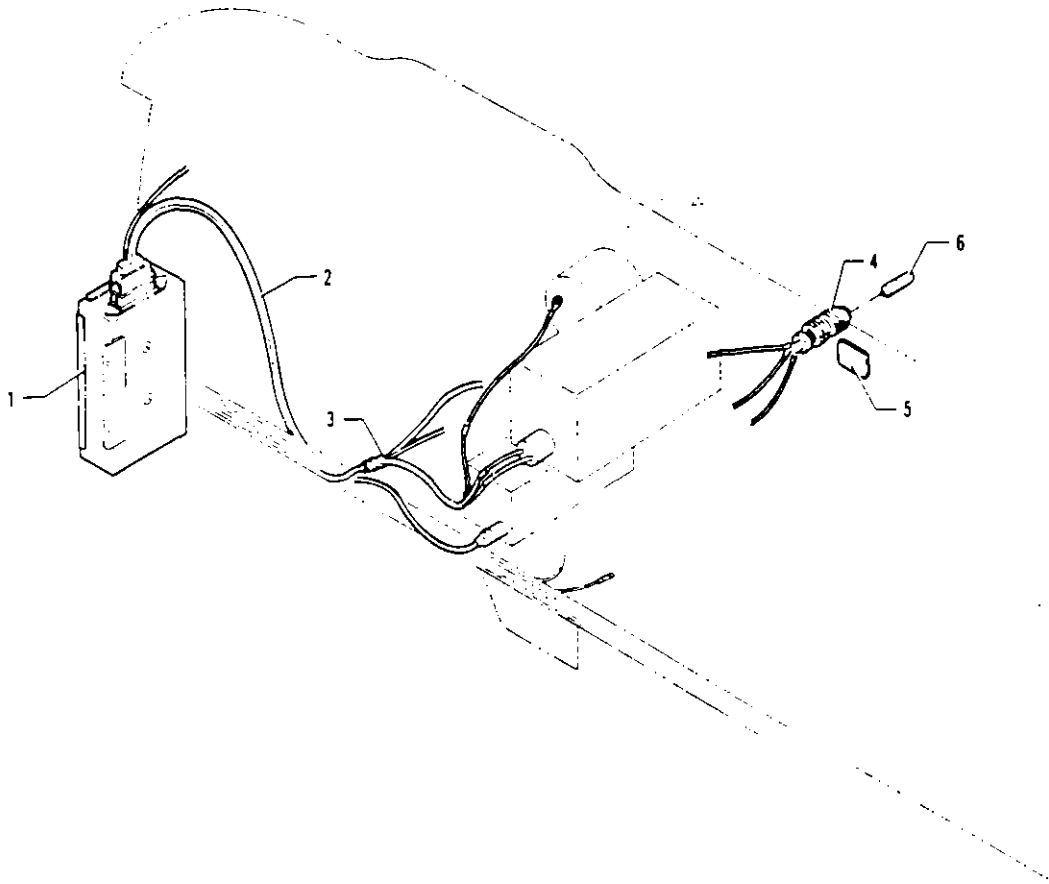

Figure 53. Glide Slope Coupler Installation

**PIPER PARTS CATALOG**

Figure and Index Number	Part Number	Code	NOMENCLATURE	No. Req.	SERIAL NUMBERS AFFECTED
			1234567		
53-	26729		DRAWING Glide Slope Coupler Installation		
-1	751 300		COUPLER ASSEMBLY - Glide slope (1C493)	1	
-2	752 010		HARNES ASSEMBLY - Glide slope coupler (30C291)	1	
-3	752 011		HARNES ASSEMBLY - Glide slope coupler (30B295)	1	
-4	752 371		INDICATOR LIGHT ASSEMBLY - Glide slope coupler (30A296)	1	
-5	43918-00		PLACARD - Glide slope coupler (581 471)	1	
-6	472 054		LAMP - Indicator light (#330)	1	

When ordering, always specify Part Number, Description and Serial Number of Aircraft

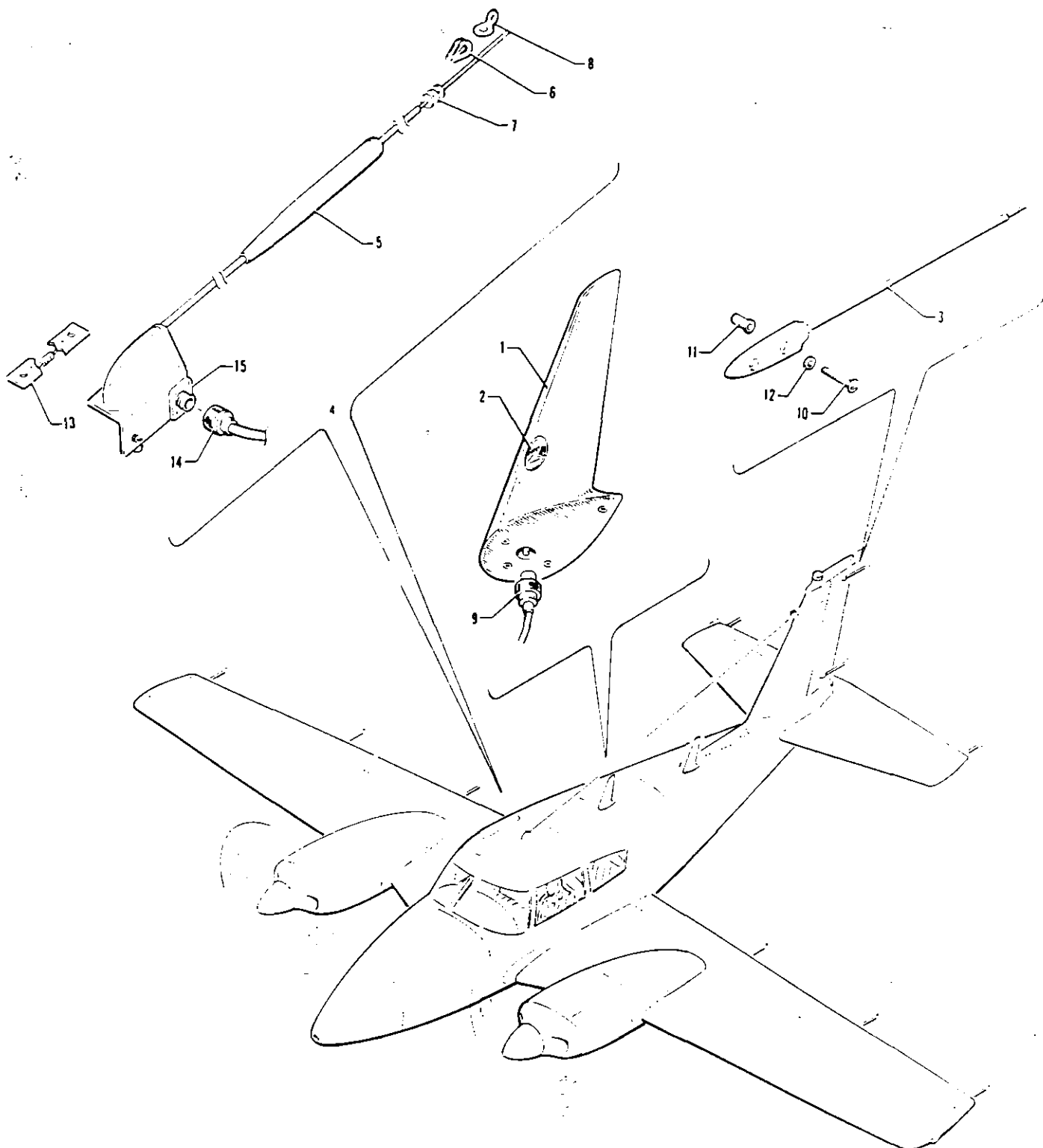

Figure 54. Anti-Static Equipment Installation

**PIPER PARTS CATALOG**

Figure and Index Number	Part Number	Code	NOMENCLATURE	No. Req.	SERIAL NUMBERS AFFECTED
54-	25043		DRAWING - Anti-Static Equipment Installation		
-1	451 800		ANTENNA ASSEMBLY - Broadband	2	
-2	456 388		DECAL - Antenna	2	
-3	494 678		WICK - Static (SW 10-96-3)	10	
-4	31614-00		ANTENNA ASSEMBLY - Sense	1	
-5	451 801		* ANTENNA ASSEMBLY - Sense	1	
-6	40111-00		* THIMBLE - Sense antenna	1	
-7	486 879		* SLEEVE - Sense antenna (28-1-C)	1	
-8	486 562		* SHACKLE - Sense antenna (MS20115-2)	1	
-9	581 043		PLUG KIT - (2329802-1) Aft antenna	1	
	460 783		FITTING - (UG914/U) Forward antenna	1	
-10	451 520		SCREW - (MS35206-230)	20	
-11	406 848		RIVNUT - (A6K75)	20	
-12	407 041		WASHER - Lock (MS35338-41)	20	
-13	24227-03		CHOKE ASSEMBLY	1	
-14	480 997		PLUG - (83-15P)	1	
	451 905	A	ADAPTER - (UG-273/U)	1	
	581 753	A	PLUG - (2-329085-2)	1	
-15	481 002		PLUG - (83-1R)	1	
			A - Used when King KR-85 ADF is installed		

When ordering, always specify Part Number, Description and Serial Number of Aircraft

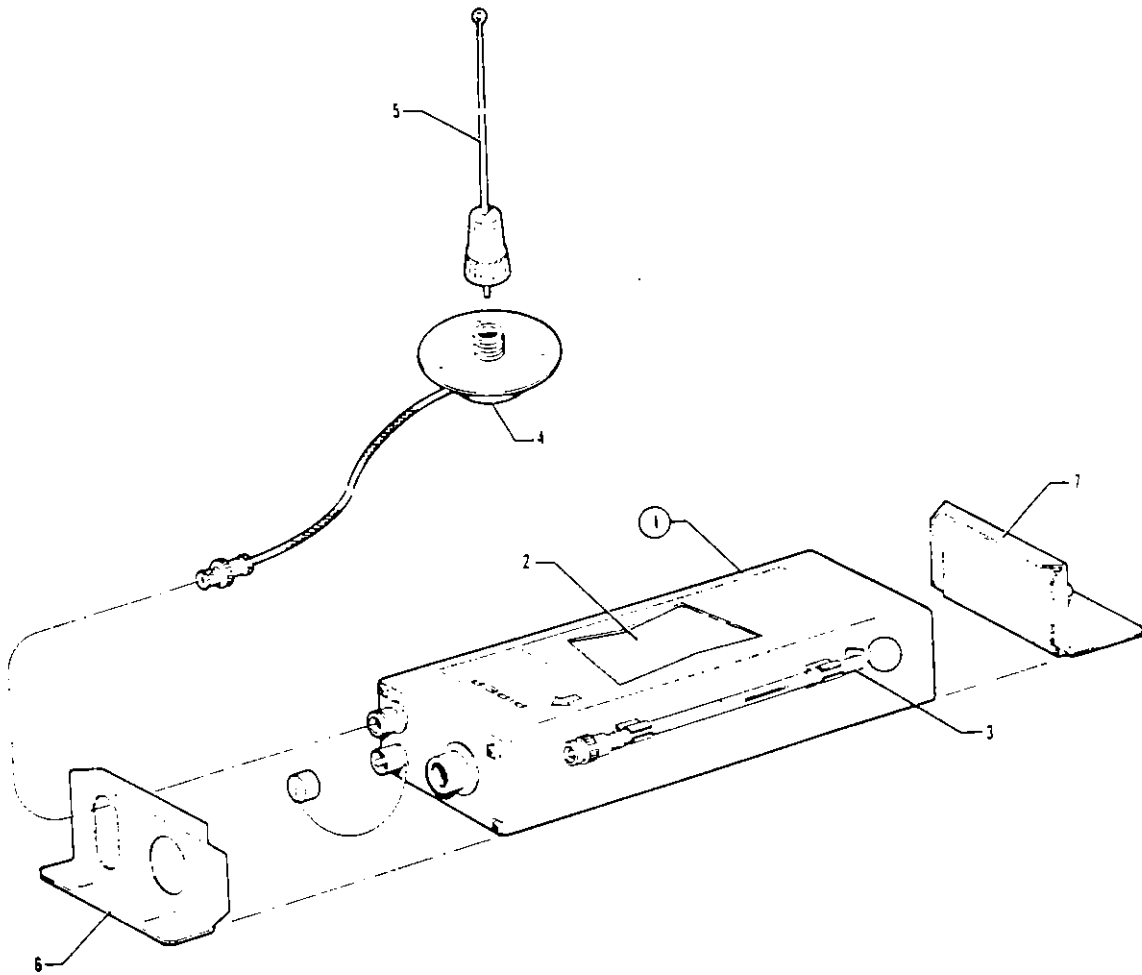

Figure 54A. Piper Automatic Locator (ELT) Installation (Garrett Mfg. Ltd.)

REVISED: MAY 1980

2C1

PA-30  
PA-39

**PIPER PARTS CATALOG**

Figure and Index Number	Part Number	Code	NOMENCLATURE	No. Req.	SERIAL NUMBERS AFFECTED
54A-	27326	A	DRAWING - Piper Automatic Locator (ELT) Installation		
	28109	B	DRAWING - Piper Automatic Locator (ELT) Installation		
-1	756 398	C	TRANSMITTER ASSEMBLY - Automatic locator (627484-1) (includes magnesium battery pack)	1	
	761 939	C	TRANSMITTER ASSEMBLY - Automatic locator (627674-1) (includes magnesium battery pack)	1	
-2	758 281		* BATTERY PACK - Transmitter assembly (magnesium)	1	
-3	751 316		* ANTENNA ASSEMBLY - Telescopic	1	
-4	751 318		CABLE AND BASE ASSEMBLY - Whip antenna	1	
-5	751 319		ANTENNA ASSEMBLY - Whip (less cable and base)	1	
-6	758 266		BRACKET - Forward transmitter mounting	1	
-7	758 267		BRACKET ASSEMBLY - Aft transmitter mounting (includes lock knob)	1	
			A - Used with Transmitter Assembly P/N 756 398 (Model 627484-1).		
			B - Used with Transmitter Assembly P/N 761 939 (Model 627674-1).		
			C - No longer available. Order ELT Replacement Kit 764 082 (Garrett ELT to Narco ELT 10) as a replacement.		

When ordering, always specify Part Number, Description and Serial Number of Aircraft

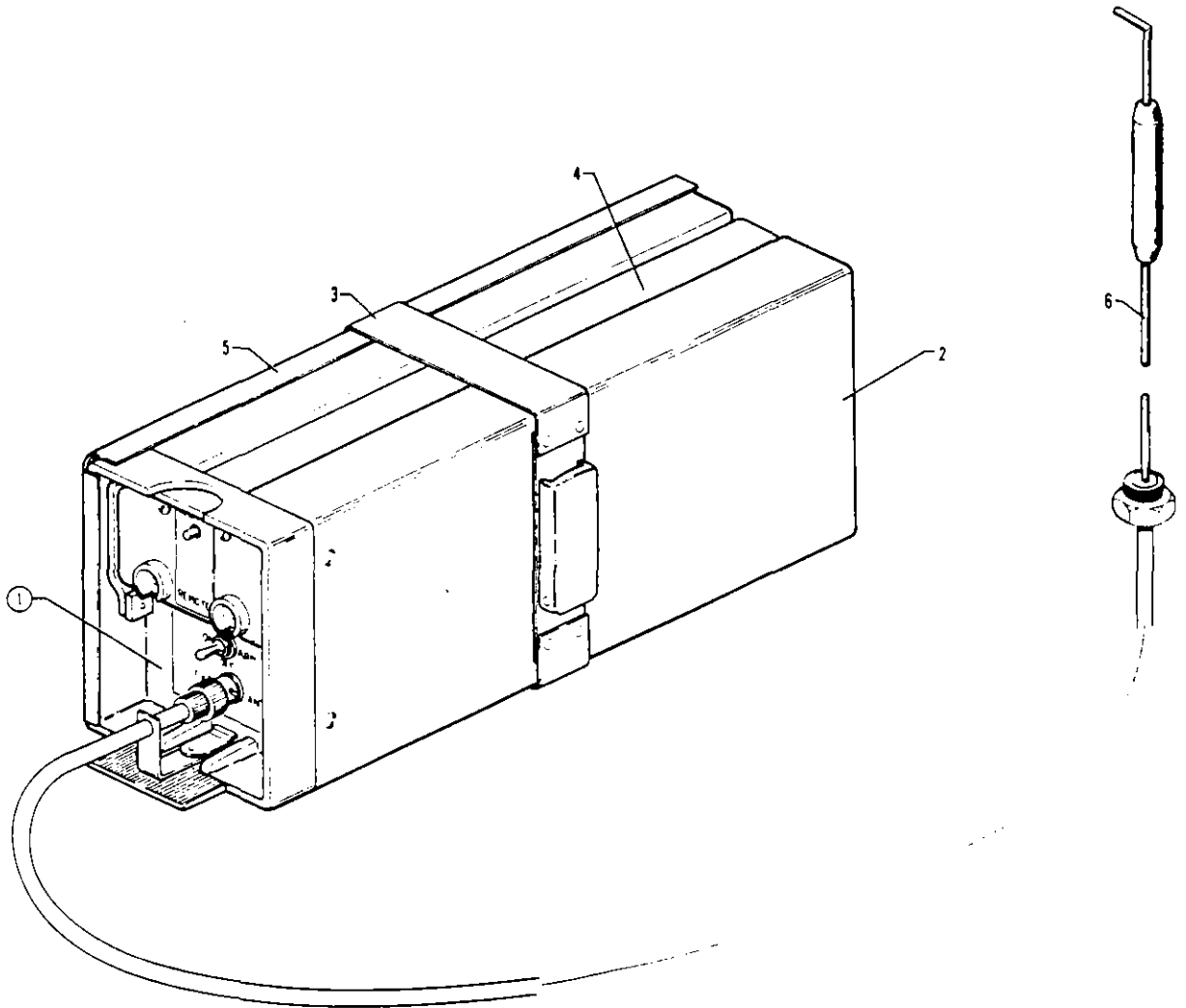

Figure 54B. Piper Automatic Locator (ELT) Installation  
(Narco Avionics)

REVISED: MAY 1980

2C3

PA-30  
PA-39



**PIPER PARTS CATALOG**

Figure and Index Number	Part Number	Code	NOMENCLATURE	No. Req.	SERIAL NUMBERS AFFECTED
54B-	66083		DRAWING - Piper Automatic Locator (ELT) Installation		
-1	54800-54		TRANSMITTER ASSEMBLY - Automatic locator (ELT 10) (includes alkaline battery pack)	1	
-2	758 452		* BATTERY PACK - Transmitter assembly (57674-0001)	1	
-3	762 357		* STRAP - Transmitter assembly (57682-0101)	1	
-4	763 019		* ANTENNA - Blade, portable (57667-0001)	1	
-5	758 453		* BASE - Transmitter assembly (57666-0001)	1	
-6	597 257		ANTENNA ASSEMBLY - ELT (01652-0101)	1	

When ordering, always specify Part Number, Description and Serial Number of Aircraft

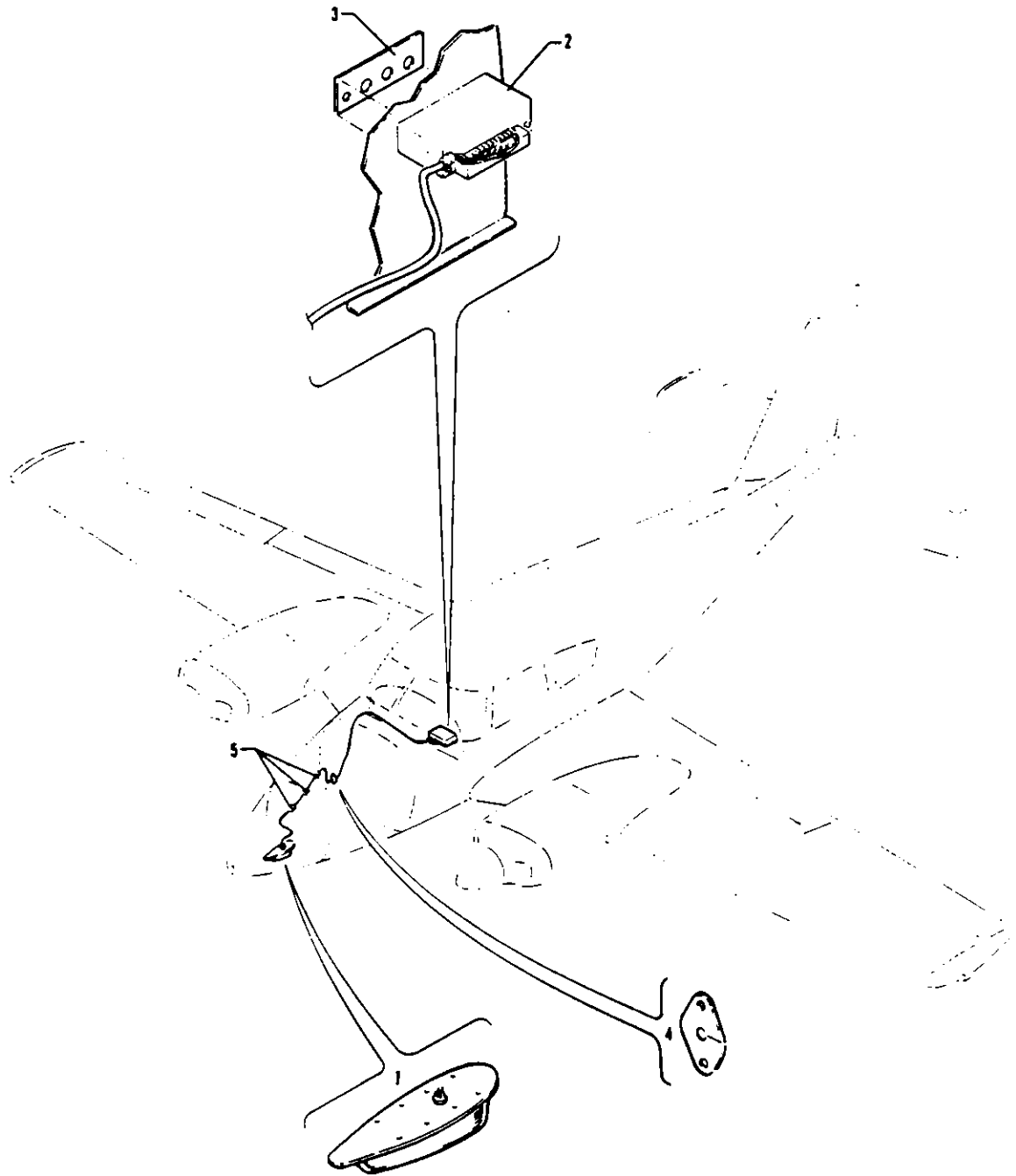

Figure 55. PM-1 Marker Beacon Installation

**PIPER PARTS CATALOG**

Figure and Index Number	Part Number	Code	NOMENCLATURE	No. Req.	SERIAL NUMBERS AFFECTED
55-	24785 26742 26801 26915 27293	A BY CDYZ CEYZ Z	DRAWING - Piper PM-1 Marker Beacon Installation DRAWING - Piper PM-1 Marker Beacon Installation DRAWING - Piper PM-1 Marker Beacon Installation DRAWING - Piper PM-1 Marker Beacon Installation DRAWING - Piper PM-1 Marker Beacon Installation		30-1717, 30-1745 to 30-1828 301781 and up, 39-1 to 39-145 30-1781 and up, 39-1 to 39-145 39-146 and up
-1	551 216		RECEIVER - Marker beacon (1-950005)	1	
-2	551 233	A	PANEL ASSEMBLY - Marker beacon control (1-950012)	1	
	32408-00	DF	PANEL ASSEMBLY - Marker beacon control	1	
	32408-02	EG	PANEL ASSEMBLY - Marker beacon control	1	
-3	24682-00	A	PLACARD - Marker beacon (581 061)	1	
-4	22105-05		GASKET - Marker beacon cable	1	
-5	487 624		STRAP ASSEMBLY - Marker beacon cable (G-123)	3	

- A - Used on PA-30 with serial numbers 30-2 to 30-1716 inclusive, 30-1718 to 30-1744 inclusive.
- B - Used when Narco Mark 12A Radio is installed.
- C - Used when Narco Mark 16 or Mark 12B Radio is installed.
- D - Used if Trim Panel Indicator Lights are installed.
- E - Used if VOA-50M Omni Converter, which incorporates indicator lights, is installed.
- F - Used on PA-30 with serial numbers 30-1717, 30-1745 and up, and PA-39 with serial numbers 39-1 and up.
- G - Used on PA-30 with serial numbers 30-1717, 30-1745 and up, and PA-39 with serial numbers 39-1 to 39-145 inclusive.
- Y - Used on PA-30 airplanes only.
- Z - Used on PA-39 airplanes only.

When ordering, always specify Part Number, Description and Serial Number of Aircraft

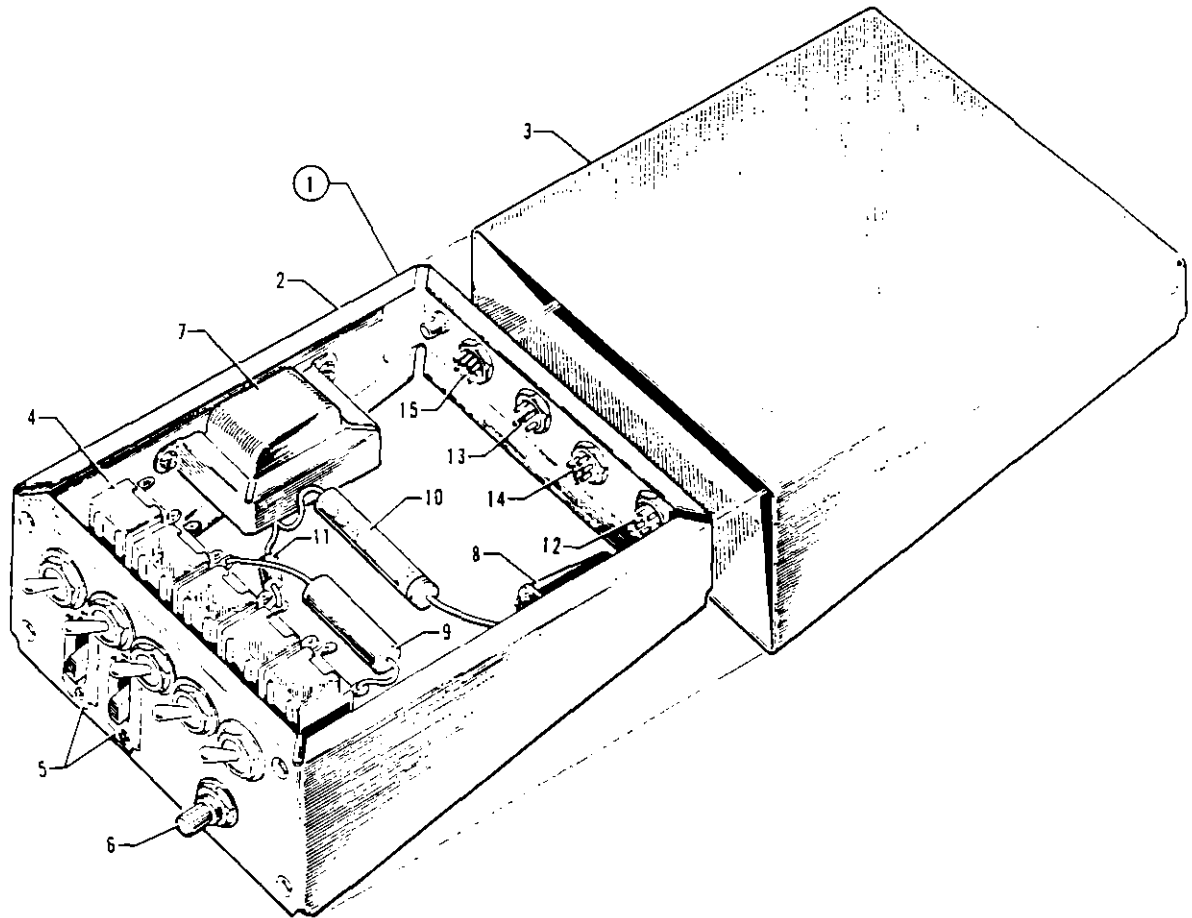

Figure 56. Radio Junction Boxes  
(PA-30 with Serial Nos. 30-2 to 30-1716 inclusive, 30-1718 to 30-1744 inclusive)



Figure and Index Number	Part Number	Code	NOMENCLATURE	No. Req	SERIAL NUMBERS AFFECTED
50-1	30960-02	F	BOX ASSEMBLY - Radio junction (complete)	1	
	30960-03	E	BOX ASSEMBLY - Radio junction (complete)	1	
	30960-04	D	BOX ASSEMBLY - Radio junction (complete)	1	
	30960-05	C	BOX ASSEMBLY - Radio junction (complete)	1	
	30960-06	B	BOX ASSEMBLY - Radio junction (complete)	1	
	30960-07	A	BOX ASSEMBLY - Radio junction (complete)	1	
	30960-08	H	BOX ASSEMBLY - Radio junction (complete)	1	
	30960-09	G	BOX ASSEMBLY - Radio junction (complete)	1	
	30960-10	J	BOX ASSEMBLY - Radio junction (complete)	1	
	30960-11	K	BOX ASSEMBLY - Radio junction (complete)	1	
	30960-12	L	BOX ASSEMBLY - Radio junction (complete)	1	
	30960-13	M	BOX ASSEMBLY - Radio junction (complete)	1	
	30960-14	N	BOX ASSEMBLY - Radio junction (complete)	1	
	30960-15	O	BOX ASSEMBLY - Radio junction (complete)	1	
	30960-16	P	BOX ASSEMBLY - Radio junction (complete)	1	
				<p>A - Used with Dual Narco Mark 12 Radio Installation.                      B - Used with Dual Narco Mark 12 Radio Installation with Marker Beacon.                      C - Used with Dual Narco Mark 12 Radio Installation with DME (UDI-2).                      D - Used with Dual Narco Mark 12 Radio Installation with DME (UDI-2) and Marker Beacon.                      E - Used with Dual Narco Mark 12 Radio Installation with Marker Beacon and Glide Slope.                      F - Used with Dual Narco Mark 12 Radio Installation with Marker Beacon, DME (UDI-2) and Glide Slope.                      G - Used with Single Narco Mark 12 Radio Installation.                      H - Used with Single Narco Mark 12 Radio Installation with Marker Beacon.                      J - Used with Single Narco Mark 12 Radio Installation with DME (UDI-2).                      K - Used with Single Narco Mark 12 Radio Installation with DME (UDI-2) and Marker Beacon.                      L - Used with Single Narco Mark 12 Radio Installation with Glide Slope.                      M - Used with Single Narco Mark 12 Radio Installation with Glide Slope and Marker Beacon.                      N - Used with Single Narco Mark 12 Radio Installation with Glide Slope and DME (UDI-2).                      O - Used with Single Narco Mark 12 Radio Installation with Glide Slope, DME (UDI-2) and Marker Beacon.                      P - Used with Bendix ADF, Narco ADF-31 or Narco ADF-31A.</p>	

When ordering, always specify Part Number, Description and Serial Number of Aircraft



Figure and Index Number	Part Number	Code	NOMENCLATURE	No. Req.	SERIAL NUMBERS AFFECTED	
50-1	26088-02	A	BOX ASSEMBLY - Radio junction (complete)	1		
	26088-03	B	BOX ASSEMBLY - Radio junction (complete)	1		
	26088-04	C	BOX ASSEMBLY - Radio junction (complete)	1		
	26088-05	D	BOX ASSEMBLY - Radio junction (complete)	1		
	26088-06	E	BOX ASSEMBLY - Radio junction (complete)	1		
	26088-07	F	BOX ASSEMBLY - Radio junction (complete)	1		
	26088-08	G	BOX ASSEMBLY - Radio junction (complete)	1		
	26088-09	H	BOX ASSEMBLY - Radio junction (complete)	1		
	26088-10	J	BOX ASSEMBLY - Radio junction (complete)	1		
	26088-11	K	BOX ASSEMBLY - Radio junction (complete)	1		
	26088-12	L	BOX ASSEMBLY - Radio junction (complete)	1		
	26088-13	M	BOX ASSEMBLY - Radio junction (complete)	1		
	26088-14	N	BOX ASSEMBLY - Radio junction (complete)	1		
	26088-15	O	BOX ASSEMBLY - Radio junction (complete)	1		
	-2	30953-00		BOX ASSEMBLY	1	
	-3	30955-00		COVER - Radio junction box	1	
-4	487 848		SWITCH - (=12TS115-1)	AR		
-5	487 846		SWITCH - (=SS-36-1-C3) Black	AR		
	487 876		SWITCH - (=SS-36-1-C1) Gray	AR		
-6	487 847		SWITCH - (=PA216-024)	1		
-7	489 372		TRANSFORMER - (=A-8101)	1		
-8	484 372		RELAY - (=KHP17D11)	1		
-9	26156-00		CAPACITOR - (5MFD 50 VDC)	1		
-10	484 358		RESISTOR - (=2W 3.3 OHM)	1		
-11	484 410		RESISTOR - (=1W 560 OHM)	1		
-12	455 226		CONNECTOR - 7 Point pin (=126-197)	1		
-13	455 228		CONNECTOR - 5 Point pin (=126-216)	1		
-14	455 227		CONNECTOR - 7 Point socket (=126-198)	1		
-15	455 229		CONNECTOR - 9 Point socket (=126-221)	1		
			A - Used with Dual Narco Mark 12A Radio Installation with Marker Beacon, DME (UDI-2A) and Glide Slope.			
			B - Used with Dual Narco Mark 12A Radio Installation with Marker Beacon and Glide Slope.			
			C - Used with Dual Narco Mark 12A Radio Installation with DME (UDI-2A) and Marker Beacon.			
			D - Used with Dual Narco Mark 12A Radio Installation with DME (UDI-2A).			
			E - Used with Dual Narco Mark 12A Radio Installation with Marker Beacon.			
			F - Used with Dual Narco Mark 12A Radio Installation.			
			G - Used with Single Narco Mark 12A Radio Installation with Marker Beacon.			
			H - Used with Single Narco Mark 12A Radio Installation.			
			J - Used with Single Narco Mark 12A Radio Installation with DME (UDI-2A).			
			K - Used with Single Narco Mark 12A Radio Installation with DME (UDI-2A) and Marker Beacon.			
			L - Used with Single Narco Mark 12A Radio Installation with Glide Slope.			
			M - Used with Single Narco Mark 12A Radio Installation with Glide Slope and Marker Beacon.			
			N - Used with Single Narco Mark 12A Radio Installation with Glide Slope and DME (UDI-2A).			
			O - Used with Single Narco Mark 12A Radio Installation with Glide Slope, DME (UDI-2A) and Marker Beacon.			

When ordering, always specify Part Number, Description and Serial Number of Aircraft

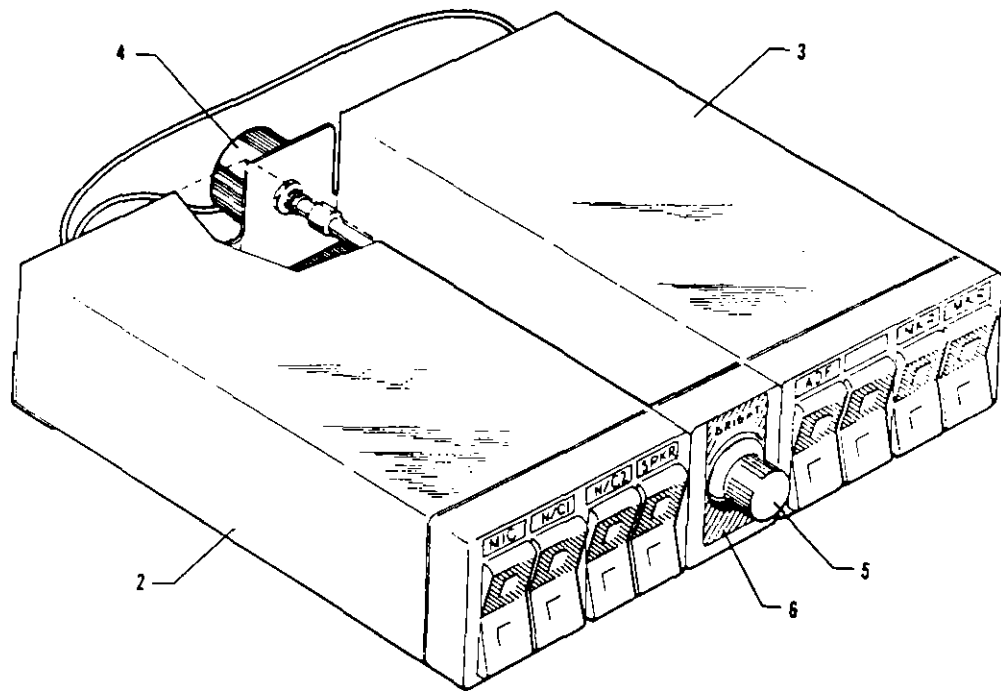

Figure 57. Radio Junction Boxes  
 (PA-30 with Serial Nos. 30-1717, 30-1745 and up)  
 (PA-39 with Serial Nos. 39-1 to 39-145 inclusive)



Figure and Index Number	Part Number	Code	NOMENCLATURE	No. Req.	SERIAL NUMBERS AFFECTED
57-1	32671-09	L	BOX ASSEMBLY - Radio junction (complete)	1	
	32671-10	C	BOX ASSEMBLY - Radio junction (complete)	1	
	32671-11	J	BOX ASSEMBLY - Radio junction (complete)	1	
	32671-12	E	BOX ASSEMBLY - Radio junction (complete)	1	
	32671-13	F	BOX ASSEMBLY - Radio junction (complete)	1	
	32671-14	D	BOX ASSEMBLY - Radio junction (complete)	1	
	32671-15	G	BOX ASSEMBLY - Radio junction (complete)	1	
	32671-16	H	BOX ASSEMBLY - Radio junction (complete)	1	
	32671-17	B	BOX ASSEMBLY - Radio junction (complete)	1	
-2	596 071	K	NARCOMASTER UNIT - (VP-22A2)	1	
-3	596 072	K	NARCOMASTER UNIT - (VP-22B1)	1	
-4	484 585		RHEOSTAT - (E-100-R1-352)	1	
-5	571 114		KNOB - (1-103D)	1	
-6	32766-00		PLACARD - Junction box	1	

A - Used on PA-30 with serial numbers 30-1717, 30-1745 and up, and PA-39 with serial numbers 39-1 to 39-145 inclusive.

B - Used with Dual Narco 12A, 12B or 16 Radio Installations with ADF.

C - Used with Dual Narco Mark 23A or 12B with Marker Beacon and less ADF.

D - Used with Dual Narco Mark 12A, 12B or 16 Radio Installations less ADF.

E - Used with Single Narco Mark 12A or 12B Radio Installations with Marker Beacon and less ADF.

F - Used with Single Narco Mark 12A or 12B Radio Installations less ADF.

G - Used with Narco ADF-31A or Bendix ADF-T-12C or King KR-85 ADF.

H - Used on Single Narco Mark 16 less ADF, Single Narco Mark 16 with ADF or Single Narco Mark 12B with ADF.

J - Used with Single Narco Mark 12B with Marker Beacon and ADF.

K - Individual switches must be ordered from an authorized Narco Sales and Service Dealer.

L - Used with Dual Narco 12A or 12B Radio Installations with Marker Beacon and ADF.

When ordering, always specify Part Number, Description and Serial Number of Aircraft



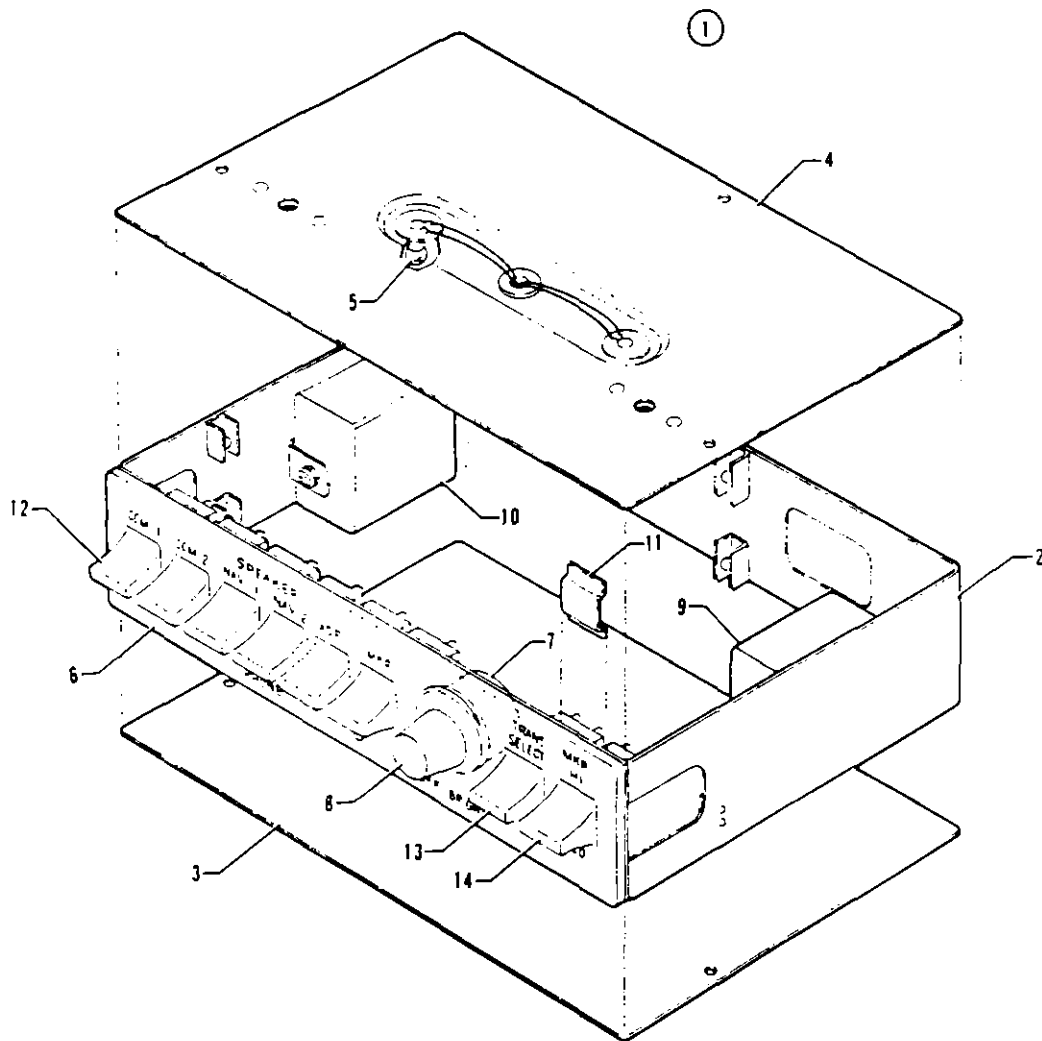

Figure 57A. Radio Junction Boxes  
(Serial Nos. 39-146 and up)

RADIO JUNCTION BOXES  
(Serial Nos. 39-146 and up)



SECTION IX  
Electronics Group

Figure and Index Number	Part Number	Code	NOMENCLATURE	No. Req.	SERIAL NUMBERS AFFECTED
57A-1	33237-02	AB	BOX ASSEMBLY - Radio junction (complete)	1	
	33237-03	AC	BOX ASSEMBLY - Radio junction (complete)	1	
	33237-04	CD	BOX ASSEMBLY - Radio junction (complete)	1	
	33237-05	CE	BOX ASSEMBLY - Radio junction (complete)	1	
	33237-06	CF	BOX ASSEMBLY - Radio junction (complete)	1	
	33237-07	AG	BOX ASSEMBLY - Radio junction (complete)	1	
	33237-08	DG	BOX ASSEMBLY - Radio junction (complete)	1	
	33237-09	EG	BOX ASSEMBLY - Radio junction (complete)	1	
	33237-10	FG	BOX ASSEMBLY - Radio junction (complete)	1	
	33237-11	BD	BOX ASSEMBLY - Radio junction (complete)	1	
	33237-12	BE	BOX ASSEMBLY - Radio junction (complete)	1	
	33237-13	H	BOX ASSEMBLY - Radio junction (complete)	1	
	33237-14	BF	BOX ASSEMBLY - Radio junction (complete)	1	
-2	33224-00		BOX ASSEMBLY - Radio junction	1	
-3	33227-00		BOTTOM - junction box	1	
-4	33232-00		LID ASSEMBLY - junction box (complete)	1	
-5	472 064		LAMP - (PS10008-348)	2	
-6	33229-02	J	PLACARD - junction box	1	
	33229-03	K	PLACARD - junction box	1	
-7	484 585		RHEOSTAT - (E-100-R1-352)	1	
-8	571 127		KNOB - (1-525-D)	1	
-9	484 214		RELAY - (T154-4C-12VDC)	1	
-10	484 193	L	RELAY - (R10-E1-Y2-V185)	1	
-11	33234-00		COVER - Switch	AR	
-12	587 867		SWITCH - (SC3BX18-1)	6	
-13	587 868		SWITCH - (SC4CW18-1)	1	
-14	587 869	J	SWITCH - (SC4CW18-2)	1	

- A - Used with Narco Single Radios less ADF.
- B - Used with or without Glide Slope and without Marker Beacon.
- C - Used with Piper Marker Beacon or Piper Marker Beacon and Glide Slope.
- D - Used with Narco Single Radios with ADF.
- E - Used with Narco Dual Radios less ADF.
- F - Used with Narco Dual Radios with ADF.
- G - Used with Narco Marker Beacon or Narco Marker Beacon and Glide Slope.
- H - Used with Narco ADF-31A, King KR-85 and Bendix ADF.
- J - Used only if Piper Marker Beacon is installed.
- K - Used only if Narco Marker Beacon is installed.
- L - Used only if Narco Dual Radios are installed.

When ordering, always specify Part Number, Description and Serial Number of Aircraft



Figure and Index Number	Part Number	Code	NOMENCLATURE	No. Req.	SERIAL NUMBERS AFFECTED
	24234	Y	DRAWING - Narco Mark 12		30-2 to 30-941 inclusive
	25633	Y	DRAWING - Narco Mark 12A		30-942 to 30-1716 inclusive, 30-1718 to 30-1744 inclusive
	24204	A	DRAWING - Narco DME Installation (UDI-2)		
	24900	A	DRAWING - Narco DME Installation (UDI-3)		
	24188	A	DRAWING - Narco Marker Beacon Installation		
	24785	A	DRAWING - Piper Marker Beacon Installation		
	24190	A	DRAWING - Motorola ADF-T12B Installation		
	24207	Y	DRAWING - Narco Glide Slope Installation		30-2 to 30-941 inclusive
	25630	Y	DRAWING - Narco Glide Slope Installation		30-942 to 30-1716 inclusive, 30-1718 to 30-1744 inclusive
	25565	Y	DRAWING - Narco ADF		30-2 to 30-1644 inclusive
	26336	Y	DRAWING - Narco ADF-31A		30-1645 to 30-1716 inclusive, 30-1718 to 30-1744 inclusive
	25040	A	DRAWING - Bendix ADF		
	25608	Y	DRAWING - Narco ADF-31		30-2 to 30-1644 inclusive
	26337	Y	DRAWING - Narco ADF-31A		30-1645 to 30-1716 inclusive, 30-1718 to 30-1744 inclusive
	30960	A	DRAWING - Junction Box Assembly		
	31124	A	DRAWING - Wiring Schematic		
	26084	A	DRAWING - Narco Single or Dual Mark 12A with 90, 100, 360 or 380 Channel, Marker Beacon, Glide Slope, DME and VOA-4 Omni Converter		
	26088	A	DRAWING - Junction Box Assembly		
	26083	A	DRAWING - Wiring Schematic		
	26748	B	DRAWING - Narco Single Mark 12A (with ADF)		
	26788	B	DRAWING - Narco Single Mark 12A (less ADF)		
	26790	B	DRAWING - Narco Dual Mark 12A (with ADF)		
	26747	B	DRAWING - Narco Dual Mark 12A (less ADF)		
	26770	B	DRAWING - Narco ADF Installation		
	26776	B	DRAWING - Bendix ADF Installation		
	26719	B	DRAWING - Narco Glide Slope Installation		
	26742	B	DRAWING - Piper Marker Beacon Installation		
	32671	B	DRAWING - Junction Box Assembly		
	26715	YZ	DRAWING - Narco DME Installation (UDI-4)		30-1717, 30-1745 and up, 39-1 to 39-145 inclusive
	27282	Z	DRAWING - King DME Installation (KN60C)		
	26777	Y	DRAWING - Bendix ADF-T-12C Installation		30-1717, 30-1745 to 30-1780
	26856	YZ	DRAWING - Bendix ADF-T-12C Installation		30-1781 and up, 39-1 to 39-145

A - Used on PA-30 with serial numbers 30-2 to 30-1716 inclusive, 30-1718 to 30-1744 inclusive.  
 B - Used on PA-30 with serial numbers 30-1717, 30-1745 to 30-1828 inclusive.  
 Y - Used on PA-30 airplanes only.  
 Z - Used on PA-39 airplanes only.

When ordering, always specify Part Number, Description and Serial Number of Aircraft



Figure and Index Number	Part Number	Code	NOMENCLATURE	No. Req.	SERIAL NUMBERS AFFECTED
	26804	Y	DRAWING - Narco ADF-31A Installation		30-1717, 30-1745 to 30-1780
	26857	YZ	DRAWING - Narco ADF-31A Installation		30-1781 and up, 39-1 to 39-145
	26906	YZ	DRAWING - Narco Single Mark 16 (with ADF)		30-1781 and up, 39-1 to 39-145
	26907	YZ	DRAWING - Narco Single Mark 16 (less ADF)		30-1781 and up, 39-1 to 39-145
	26904	YZ	DRAWING - Narco Dual Mark 16 (with ADF)		30-1781 and up, 39-1 to 39-145
	26905	YZ	DRAWING - Narco Dual Mark 16 (less ADF)		30-1781 and up, 39-1 to 39-145
	26850	YZ	DRAWING - Narco ADF Installation		30-1781 and up, 39-1 to 39-145
	26826	YZ	DRAWING - Bendix ADF Installation		30-1781 and up, 39-1 to 39-145
	26918	YZ	DRAWING - Narco Glide Slope Installation		30-1781 and up, 39-1 to 39-145
	32671	YZ	DRAWING - Junction Box Assembly		30-1781 and up, 39-1 to 39-145
	27218	Z	DRAWING - King Radio Installation, KR-85 ADF		39-89 to 39-145 inclusive
	32671	Z	DRAWING - Junction Box Assembly		39-89 to 39-145 inclusive
	27294	Z	DRAWING - Narco Transponder Installation (AT6-A)		39-146 and up
	27281	Z	DRAWING - King Radio Installation, KR-85 ADF		39-146 and up
	33237	Z	DRAWING - Junction Box Assembly		39-146 and up
	27286	Z	DRAWING - Narco Radio Installation, ADF-31A		39-146 and up
	33237	Z	DRAWING - Junction Box Assembly		39-146 and up
	27287	Z	DRAWING - Bendix Radio Installation, ADF		39-146 and up
	33237	Z	DRAWING - Junction Box Assembly		39-146 and up
	27300	Z	DRAWING - Narco Radio Installation, Single COM 11A (less ADF)		39-146 and up
	27301	Z	DRAWING - Narco Radio Installation, Single COM 11A (with ADF)		39-146 and up
	27302	Z	DRAWING - Narco Radio Installation, Dual COM 11A (less ADF)		39-146 and up
	27303	Z	DRAWING - Narco Radio Installation, Dual COM 11A (with ADF)		39-146 and up
	33237	Z	DRAWING - Junction Box Assembly		39-146 and up
	27295	Z	DRAWING - Narco Glide Slope Installation		39-146 and up
	27296	Z	DRAWING - Narco Marker Beacon Installation		39-146 and up
	27284	Z	DRAWING - Narco ADF Installation		39-146 and up
	27285	Z	DRAWING - Bendix ADF Installation		39-146 and up
	25759	A	DRAWING - Narco Transponder		
	26638	Y	DRAWING - Narco Transponder (UAT-1) (with UTC-1 Control Unit)		30-1717, 30-1745 to 30-1950
	26894	YZ	DRAWING - Narco Transponder (AT6-A)		30-1781 and up, 39-1 to 39-145
	27007	YZ	DRAWING - Narco Transponder (UAT-1) (with UTC-2 Control Unit)		30-1781 and up, 39-1 to 39-94
	27215	Z	DRAWING - Narco Transponder (AT5-A)		39-95 to 39-145 inclusive
	27272	Z	DRAWING - Narco Transponder (AT-50)		39-146 and up
	26944	YZ	DRAWING - Narco Single Mark 12B (with ADF)		30-1829 and up, 39-1 to 39-145
	26945	YZ	DRAWING - Narco Single Mark 12B (less ADF)		30-1829 and up, 39-1 to 39-145
	26946	YZ	DRAWING - Narco Dual Mark 12B (with ADF)		30-1829 and up, 39-1 to 39-145
	26947	YZ	DRAWING - Narco Dual Mark 12B (less ADF)		30-1829 and up, 39-1 to 39-145
	26850	YZ	DRAWING - Narco ADF Installation		30-1829 and up, 39-1 to 39-145
	26826	YZ	DRAWING - Bendix ADF Installation		30-1829 and up, 39-1 to 39-145
	26719	YZ	DRAWING - Narco Glide Slope Installation		30-1829 and up, 39-1 to 39-145
	32671	YZ	DRAWING - Junction Box Assembly		30-1829 and up, 39-1 to 39-145

A - Used on PA-30 with serial numbers 30-1454 to 30-1716 inclusive, 30-1718 to 30-1744 inclusive.  
 Y - Used on PA-30 airplanes only.  
 Z - Used on PA-39 airplanes only.

When ordering, always specify Part Number, Description and Serial Number of Aircraft



Figure and Index Number	Part Number	Code	NOMENCLATURE	No. Req.	SERIAL NUMBER AFFECTED
			OPTIONAL EQUIPMENT KITS		
	754 435	H	WINDOW CURTAIN INSTALLATION KIT		
	756 971	Y	WINDOW CURTAIN INSTALLATION		30-853, 30-902 to 30-1716, 30-1718 to 30-1744 inclusive
	760 255	K	WINDOW CURTAIN INSTALLATION		
	756 751	AH	WINDOW CURTAINS - CHAMPAGNE		
	756 970	JY	WINDOW CURTAINS - IVORY WHITE		30-853, 30-902 to 30-1716, 30-1718 to 30-1744 inclusive
	760 256	KL	WINDOW CURTAINS - BEIGE		
	760 257	KL	WINDOW CURTAINS - IVORY		
	760 258	KL	WINDOW CURTAINS - WHITE		
	756 734	CY	DUAL GENERATOR INSTALLATION		30-2 to 30-1716 inclusive, 30-1718 to 30-1744 inclusive
	756 735	D	DRY VACUUM PUMP INSTALLATION		
	756 736	E	EXTINGUISHER INSTALLATION - FIRE		
	756 747		HEATED PITOT TUBE INSTALLATION		
	756 754	YZ	DUAL TOE BRAKE INSTALLATION		30-2 and up, 39-1 to 39-83 incl.
	760 846	Z	DUAL TOE BRAKE INSTALLATION		39-84 and up
	24217-00	FY	PANEL ASSEMBLY - GLAR BAN, LEFT (complete)		30-2 to 30-704 inclusive
	24217-03	BF	PANEL ASSEMBLY - GLAR BAN, LEFT (Complete)		
	25575-00	FY	PANEL ASSEMBLY - GLAR BAN, LEFT (Complete)		30-853, 30-902 to 30-1400
	25786-00	FY	PANEL ASSEMBLY - GLAR BAN, LEFT (Complete)		30-1401 to 30-1655 inclusive
	24217-04	GH	PANEL ASSEMBLY - GLAR BAN, LEFT (Complete)		
	25575-02	GY	PANEL ASSEMBLY - GLAR BAN, LEFT (Complete)		30-853, 30-902 to 30-1400
	25786-02	GY	PANEL ASSEMBLY - GLAR BAN, LEFT (Complete)		30-1401 to 30-1716 inclusive, 30-1718 to 30-1744 inclusive

A - Less Installation Kit 754 435.  
 B - Used on PA-30 with serial numbers 30-905 to 30-852 inclusive, 30-854 to 30-901 inclusive.  
 C - Secure generator, paralleling relay and voltage regulator from Lycoming, Division-Avco Corporation, Williamsport, Penna.  
 D - This Kit is less the following items which must be ordered separately. Vacuum Pump, Piper Part No. 481 692 (2 Req. on PA-30 only). Vacuum Pumps, Piper Part Nos. 481 692 and 26749-05 (1 each Req. on PA-39 only). Suction Gauge, Piper Part No. 550 606 (1 Req.). Plug Adapter, Lycoming Part No. 61098 (2 Req.). Drive Gear, Lycoming Part No. 72970 (2 Req.). Secure Lycoming parts from Lycoming, Division-Avco Corporation, Williamsport, Penna.  
 E - Less fire extinguisher, Part No. 459 848.  
 F - Used when 3 inch gyros are not installed.  
 G - Used when 3 inch gyros are installed.  
 H - Used on PA-30 with serial numbers 30-2 to 30-852 inclusive, 30-854 to 30-901 inclusive.  
 J - Less Installation Kit 756 971.  
 K - Used on PA-30 with serial numbers 30-1717, 30-1745 and up, and PA-39 with serial numbers 39-1 and up.  
 L - Less Installation Kit 760 255.  
 Y - Used on PA-30 airplanes only.  
 Z - Used on PA-39 airplanes only.

When ordering, always specify Part Number, Description and Serial Number of Aircraft

**PIPER PARTS CATALOG**

Figure and Index Number	Part Number	Code	NOMENCLATURE	No. Req.	SERIAL NUMBERS AFFECTED
OPTIONAL EQUIPMENT KITS (cont.)					
	24216-00	A	PANEL ASSEMBLY - GLAR BAN, UPPER RIGHT (Complete)		30-853, 30-902 to 30-1400 30-1401 to 30-1716 inclusive, 30-1718 to 30-1744 inclusive
	25278-00	B	PANEL ASSEMBLY - GLAR BAN, LOWER RIGHT (Complete)		
	25566-00	Y	PANEL ASSEMBLY - GLAR BAN, RIGHT (Complete)		
	25784-00	Y	PANEL ASSEMBLY - GLAR BAN, RIGHT (Complete)		
	760 271	D	GLAR BAN INSTRUMENT LIGHTING		30-853, 30-902 and up, 39-1 and up
	30353-20	EY	INSTRUMENT - TRUE AIRSPEED INDICATOR		
	30353-18	Z	INSTRUMENT - TRUE AIRSPEED INDICATOR		
	756 781	AC	EXTERNAL POWER RECEPTACLE INSTALLATION		
	756 980	C	EXTERNAL POWER RECEPTACLE INSTALLATION		
	62355-02		EXTERNAL POWER CONNECTOR PLUG ASSEMBLY		
	756 826		PIPER NAV-TIMER		30-1 to 30-1716 inclusive, 30-1718 to 30-1744 inclusive
	756 784		PIPER ALL-WEATHER ANTENNA		
	551 215		PIPER GLIDE SLOPE ANTENNA		
	551 229		PIPER GLIDE SLOPE ANTENNA (Ribbon Type)		
	756 879		WING TIP TANK INSTALLATION (Complete)		
	756 901		ALTERNATE STATIC SYSTEM INSTALLATION		
	756 924		HEATED WINDSHIELD INSTALLATION		
	756 828		CENTRAL AIR FILTER KIT		
	756 830	Y	MANUAL ELECTRIC PITCH TRIM KIT		
	760 273	D	MANUAL ELECTRIC PITCH TRIM KIT		
	756 845	Y	AUTOMATIC ELECTRIC PITCH TRIM KIT		
	756 846	Y	PIPER OMNI COUPLER KIT (Used with Altimatec II or AutoControl II)		
	757 074	Y	PIPER OMNI COUPLER KIT (Used with Altimatec III or AutoControl III)		
	760 259	D	PIPER OMNI COUPLER KIT (Used with Altimatec III or AutoControl III)		
	760 245	D	GLIDE SLOPE COUPLER KIT		

- A - Used on PA-30 with serial numbers 30-2 to 30-852 inclusive, 30-854 to 30-901 inclusive.
- B - Used on PA-30 with serial numbers 30-825 to 30-852 inclusive, 30-854 to 30-901 inclusive and 30-2 to 30-824 inclusive if Kit 756 909 has been installed.
- C - Less Power Connector Plug Assembly, Piper Part No. 62355-02.
- D - Used on PA-30 with serial numbers 30-1717, 30-1745 and up, and PA-39 with serial numbers 39-1 and up.
- E - Order Part No. 30353-18 if counter-rotating right engine is installed.
- Y - Used on PA-30 airplanes only.
- Z - Used on PA-39 airplanes only.

When ordering, always specify Part Number, Description and Serial Number of Aircraft

**PIPER PARTS CATALOG**

Figure and Index Number	Part Number	Code	NOMENCLATURE	No. Req	SERIAL NUMBERS AFFECTED
OPTIONAL EQUIPMENT KITS (cont.)					
756 843		A	PIPER ALTIMATIC II (3 inch gyros)		
756 976		Y	PIPER ALTIMATIC II (3 inch gyros)		30-853, 30-902 to 30-1254
757 064		HY	PIPER ALTIMATIC III (3 inch gyros)		30-1255 to 30-1716 inclusive 30-1718 to 30-1744 inclusive
760 309		Y	PIPER ALTIMATIC IIIB (3 inch gyros)		30-1717, 30-1745 and up
760 445		Z	PIPER ALTIMATIC IIIB (3 inch gyros)		39-1 to 39-145 inclusive
760 644		Z	PIPER ALTIMATIC IIIB-1		39-146 and up
756 853		A	PIPER AUTOCONTROL II (course selector)(3 inch gyros)		
756 978		Y	PIPER AUTOCONTROL II (course selector)(3 inch gyros)		30-853, 30-902 to 30-1254
757 069		HY	PIPER AUTOCONTROL III (3 inch gyros)		30-1255 to 30-1716 inclusive, 30-1718 to 30-1744 inclusive
760 263		G	PIPER AUTOCONTROL III (3 inch gyros)		
550 758		F	PIPER MIXTURE CONTROL INDICATOR KIT		
756 909		Y	PIPER MIXTURE CONTROL INDICATOR INSTALLATION		30-2 to 30-824 inclusive
756 925			SAFETY MIRROR		
756 943		AC	OXYGEN SYSTEM (4 Place)		
757 100		CY	OXYGEN SYSTEM (4 place)		30-853, 30-902 to 30-1716, 30-1718 to 30-1744 inclusive
760 265		CDG	OXYGEN SYSTEM (4 Place)		
757 054		BCE	OXYGEN SYSTEM CONVERSION (4 to 6 Place)		
753 692			PIPER NOISE CANCELLING MICROPHONE (with mounting bracket)		
474 647			MICROPHONE - (Telephonics #RS-38A)		
474 654			MICROPHONE - (Telex #TEL-66C)		
464 362			HEADSET - (#61650-03, 600 OHM'S)		
27004-00			HEADSET AND BOOM MIKE ASSEMBLY - (464 369)		
<p>A - Used on PA-30 with serial numbers 30-2 to 30-852 inclusive, 30-854 to 30-901 inclusive.</p> <p>B - Less two oxygen outlet trim plates 26524-02 beige, 26524-03 black, or 26524-04 white for serial numbers 30-1717, 30-1745 and up.</p> <p>C - Oxygen masks must be ordered separately. See Oxygen System Installation for Part Nos.</p> <p>D - Less two oxygen outlet trim plates 26524-02 beige, 26524-03 black, or 26524-04 white and one oxygen outlet trim plate 26535-02 beige, 26535-03 black, or 26535-04 white.</p> <p>E - Used on PA-30 with serial numbers 30-853 to 30-902 and up, and PA-39 with serial numbers 39-1 and up.</p> <p>F - Installation Kit 756 909 required when installing 550 758 Kit on serial numbers 30-2 to 30-824 inclusive.</p> <p>G - Used on PA-30 with serial numbers 30-1717, 30-1745 and up, and PA-39 with serial numbers 39-1 and up.</p> <p>H - Glar Ban Cover Panel 25786-02 and Gyro Insert Panel 25713-00 are required for serial numbers 30-1255 to 30-1655 inclusive, and must be ordered separately.</p> <p>Y - Used on PA-30 airplanes only.</p> <p>Z - Used on PA-39 airplanes only.</p>					

When ordering, always specify Part Number, Description and Serial Number of Aircraft

### PIPER PARTS CATALOG

Figure and Index Number	Part Number	Code	NOMENCLATURE	No. Req.	SERIAL NUMBERS AFFECTED
OPTIONAL EQUIPMENT KITS (cont.)					
	756 966	BY	FAMILY SEAT INSTALLATION - (One seat) Brown		30-853, 30-902 to 30-1716, 30-1718 to 30-1744 inclusive
	756 967	BY	FAMILY SEAT INSTALLATION - (One seat) Red		30-853, 30-902 to 30-1716, 30-1718 to 30-1744 inclusive
	756 968	BY	FAMILY SEAT INSTALLATION - (One seat) Blue		30-853, 30-902 to 30-1716, 30-1718 to 30-1744 inclusive
	756 969	BY	FAMILY SEAT INSTALLATION - (One seat) Gold		30-853, 30-902 to 30-1716, 30-1718 to 30-1744 inclusive
	756 985	BY	FAMILY SEAT INSTALLATION - (One seat) Black		30-853, 30-902 to 30-1716, 30-1718 to 30-1744 inclusive
	760 266	CD	FAMILY SEAT INSTALLATION - (One seat) Red		
	760 267	CD	FAMILY SEAT INSTALLATION - (One seat) Blue		
	760 268	CD	FAMILY SEAT INSTALLATION - (One seat) White		
	760 269	CD	FAMILY SEAT INSTALLATION - (One seat) Black		
	760 270	CD	FAMILY SEAT INSTALLATION - (One seat) Gold		
	756 983		REGENCY TRANSPONDER		
	757 048	AYZ	DUAL TACHOMETER INSTALLATION		30-825 and up, 39-1 and up
	25606-00	Y	PLOTTER ASSEMBLY - Weight and balance		
	27098-00	Z	PLOTTER ASSEMBLY - Weight and balance		
	757 112		NITROGEN CYLINDER ASSEMBLY - (With fittings)		

- A - Less Dual Tachometer 25700-02 and Hour Meter 25701-00 for PA-30 with serial numbers 30-825 to 30-1716 inclusive, 30-1718 to 30-1744 inclusive, or Hour Meter 32658-00 for PA-30 with serial numbers 30-1717, 30-1745 and up, and PA-39 with serial numbers 39-1 and up.
- B - Less seat back 25535-02 (vinyl), 25535-03 (leather) or 25535-23 (leather with cloth insert) and seat bottom 25534-02 (vinyl), 25534-03 (leather) or 25534-18 (leather with cloth insert).
- C - Less seat back 26584-02 (specify all vinyl or vinyl with cloth insert) or seat back 26584-03 (specify all leather or leather with cloth insert) and seat bottom 26591-02 (specify all vinyl or vinyl with cloth insert) or seat bottom 26591-03 (specify all leather or leather with cloth insert).
- D - Used in PA-30 with serial numbers 30-1717, 30-1745 and up, and PA-39 with serial numbers 39-1 and up.
- Y - Used on PA-30 airplanes only.
- Z - Used on PA-39 airplanes only.

When ordering, always specify Part Number, Description and Serial Number of Aircraft



**PIPER PARTS CATALOG**

Figure and Index Number	Part Number	Code	NOMENCLATURE	No. Req.	SERIAL NUMBERS AFFECTED
OPTIONAL EQUIPMENT KITS (cont.)					
	760 440	BZ	SHOULDER HARNESS INSTALLATION (One Seat)		
	760 439	CZ	INERTIA REEL SHOULDER HARNESS INSTALLATION (One Seat)		
	760 845	Y	SHOULDER HARNESS INSTALLATION (Front Seats)		30-2 and up
	760 844	Y	INERTIA REEL SHOULDER HARNESS INSTALLATION (Front Seats)		30-2 and up
	760 621	Y	PROPELLER SYNCHROPHASER INSTALLATION		
	760 622	Z	PROPELLER SYNCHROPHASER INSTALLATION		
	760 627	Y	LANDING GEAR EMERGENCY EXTENSION SECURITY INSTALLATION		30-2 to 30-1716, 30-1717 to 30-1744 incl.
	761 082	Y	NOSE GEAR DOWN LOCK SPRING INSTALLATION		30-2 to 30-1716, 30-1717 to 30-1744 incl.
	760 744	D	ALTERNATOR WARNING LIGHT INSTALLATION		
	764 082		ELT REPLACEMENT (Garrett ELT to Narco ELT 10)		
REPAIR KITS					
	754 321		FUEL CELL REPAIR		
	756 729	A	FIBERGLAS - Reinforced Plastic Repair		
	756 730		GEAR OLEO "O" RINGS AND SEALS		
	756 731		GEAR OLEO BUSHINGS		
	756 732		LANDING GEAR NUT AND BOLT		
	756 733		BRAKE SYSTEM SEALS AND "O" RINGS		
	756 739		PROPELLER REPAIR (One Propeller)		
	754 232		HI-SHEAR RIVET		
TOOLS					
	756 771		AIR PRESSURE GAUGE AND VALVE (Propeller)		
	26347-00		TORQUE WRENCH ADAPTER - Landing Gear Retraction		
<p>A - Secure from Service Spares Department, Piper Aircraft Corporation, Vero Beach, Florida.</p> <p>B - This Kit is less the Harness Assembly which must be purchased separately; Front Harness Assembly Part No. 43813-06 Fawn, Part No. 43813-07 Black or Part No. 43813-08 Blue and Center Harness Assembly Part No. 43813-03 Fawn, Part No. 43813-04 Black or Part No. 43813-05 Blue.</p> <p>C - This Kit is less the Harness Assembly which must be purchased separately; Front Harness Assembly 44762-04 Black or Center Harness Assembly 44762-03 Black.</p> <p>D - Used on PA-30 with serial numbers 30-1717, 30-1745 to 30-2000 inclusive, and PA-39 with serial numbers 39-1 to 39-145 inclusive.</p> <p>Y - Used on PA-30 airplanes only.</p> <p>Z - Used on PA-39 airplanes only.</p>					

When ordering, always specify Part Number, Description and Serial Number of Aircraft

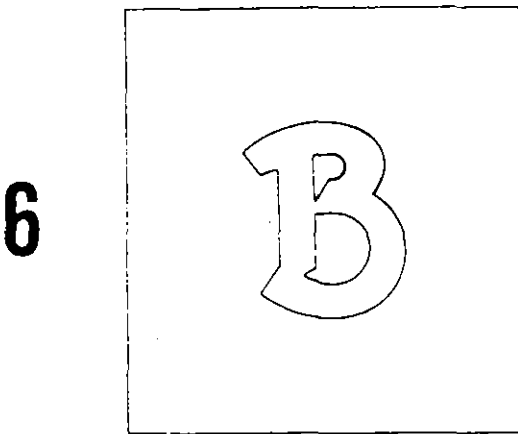
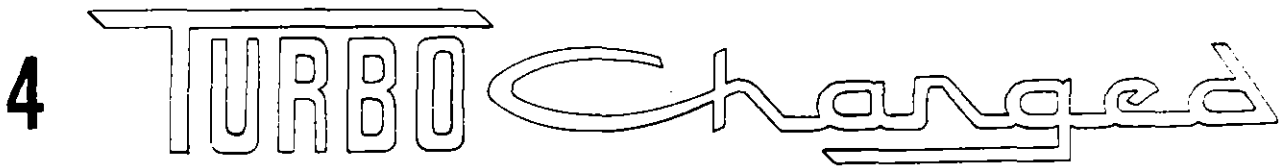
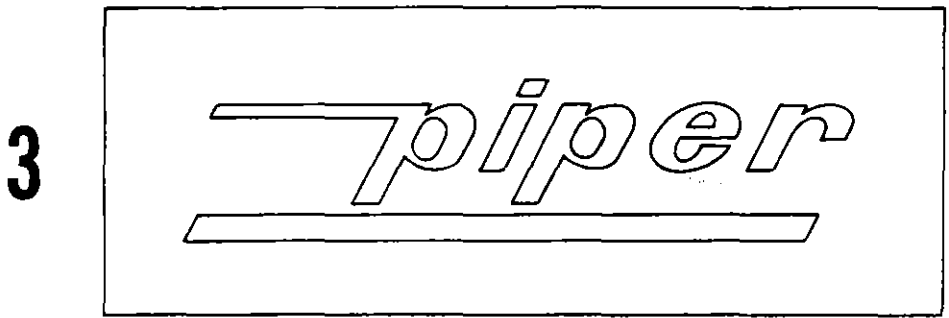
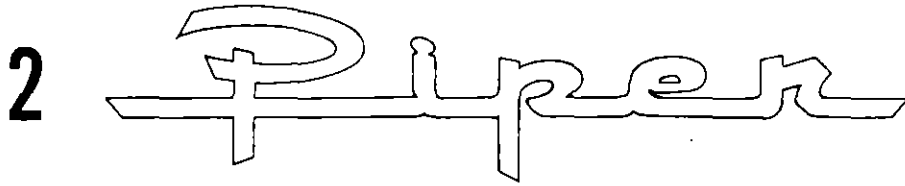
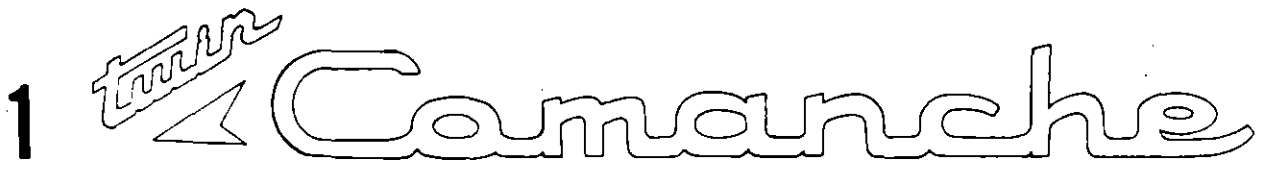

- 1. 24156-00 - STENCIL - Twin Comanche
- 2. 22859-00 - STENCIL - Piper
- 3. 50613-02 - DECAL - Piper
- 4. 25681-00 - STENCIL - Turbo Charged
- 5. 27122-00 - DECAL - Turbo Charged
- 6. 25623-00 - STENCIL - "B"
- 7. 27089-00 - DECAL - Counter Rotating

2022 THRU 2024  
INTENTIONALLY LEFT BLANK

# NUMERICAL INDEX

Part Number	Fig. and Index
10016-57	36-17
10487-06	35-53
10525-51	35-1
10525-95	35-57
10525-100	21-27
11199-06	14-1
11199-06	17-48
11199-07	14-1
11203-02	14-16
11203-02	14-53
11473-91	2-1
11601-03	24-12
11987-63	19-1
11987-67	19-51
11987-69	19-55
11987-71	19-1
12073-00	18-7
12073-00	18A-17
12073-00	18A-33
12073-00	18B-6
13002-00	39-16
13098-00	24-7
13445-07	43-28
13586-19	19-2
13586-32	30-60
13586-40	42-11
13586-41	42-12
13586-57	41-85
13586-57	42-30
13586-58	42-3
13586-58	42-26
13586-70	21-1
13586-70	21-30
13586-76	21-2
13586-85	30-6
13586-87	41-87
13945-42	2-2
13945-60	2-49
13947-29	18A-2a
13947-46	18-34
13947-46	18A-1
13947-55	18-35
13947-55	18A-2a
13947-59	18-35
13947-62	18-34
13947-65	18-35
13847-65	18A-2a
13947-68	18-34

Part Number	Fig. and Index
13942-68	18A-1
13947-75	18A-1
13947-76	18A-2a
13947-87	18A-2
13947-88	18A-2
13947-89	18A-2
13947-90	18A-2
13950-00	15-31
13950-00	15-41
13950-00	15-51
14069-00	41-94
14069-00	42-20
14175-05	37-79
14175-35	25-59
14175-43	18-6
14175-43	188-5
14175-45	13-31
14175-50	25-1
14175-103	25-59
14175-113	24-5
14175-114	19-66
14183-06	52-1
14183-06	52A-49
14226-19	41-91
14226-19	42-22
14226-32	41-92
14226-34	41-1
14226-35	41-1
14226-36	42-13
14300-09	45-3
14300-30	48-25
14300-30	52-60
14300-30	52A-35
14311-37	41-2
14311-38	41-2
14493-00	23-29
14843-07	17A-27
14843-10	16-13
14843-10	16A-32
14843-16	25-56
14843-18	24-20
14843-18	24-22
14843-18	24-24
14843-18	24-26
14843-19	24-27
14843-20	25-2
14843-20	25-3
14843-30	25-4

Part Number	Fig. and Index
14843-32	18-24
14843-34	48-27
14843-35	45-45
14843-36	45-25
14843-37	45-26
14843-38	45-27
14843-39	45-28
14843-48	44-5
14843-51	18-43
14843-51	18A-3
14843-60	25-57
14843-62	29-1
14843-69	25-5
14843-78	16-29
14843-78	16A-37
14843-79	25-6
14843-79	29-40
14843-88	29-12
14843-89	16-28
14843-93	25-3
14843-95	47-14
14843-99	16-31
14843-104	47-25
14843-113	14A-67
14976-02	43-40
14976-03	43-40
14976-06	43-3
14976-09	28-6
14976-09	45-46
14976-11	26-17
14976-12	24-9
14976-13	24-5
14976-15	24-3
14976-16	24-4
14976-17	24-54
14976-21	24-5
14976-23	24-5
14976-42	48-7
14976-52	48-10
14976-64	30-7
14976-65	30-8
14976-66	22-1
14976-68	17-21
14976-72	2-6
14976-72	46-40
14976-73	2-5
14976-73	46-41
14976-74	46-54

Part Number	Fig. and Index
14976-79	45-29
14976-80	46-25
14976-81	46-26
14976-82	46-42
14976-83	46-39
14976-84	45-30
14976-93	41-4
14976-95	37-29
14976-97	47-4
14876-98	47-3
14976-99	47-2
14976-100	47-1
14976-101	41-3
14976-102	24-5
14976-104	52-14
15780-02	45-12
16089-05	33-8
16090-00	40-32
16090-01	40-32
16268-06	21-36
16268-06	38-74
16268-08	38-1
16268-17	35-48
16439-00	52-9
16439-00	52A-50
16514-00	17-14
16564-06	35-2
16564-07	35-2
16564-08	35-2
16564-09	35B-1
16564-10	35B-1
16569-74	37-30
16633-22	38-2
16633-33	22-9
16633-36	22-24
16633-36	22-29
16633-36	38-3
16633-37	21-3
16633-37	38-4
16633-47	38-3
16633-65	52-61
16633-65	52A-38
16633-66	52-62
16633-67	23B-65
16633-67	23C-63
16633-70	22-6
16633-71	22-24
16633-71	22-29

# PIPER PARTS CATALOG

Part Number	Fig. and Index	Part Number	Fig. and Index	Part Number	Fig. and Index	Part Number	Fig. and Index
16633-94	22-6	17871-10	13-16	19359-00	18-18	20183-05	33-21a
16633-95	23-35	17881-04	14A-75	19365-00	18-17	20185-04	33-10
16722-02	48-13	17881-04	23-34	19365-00	18A-22	20193-04	32-35
16771-00	45-18	17881-04	23-46	19365-00	18A-38	20193-05	32-36
16914-00	31-3	17952-00	12-15	19365-00	18B-9	20193-06	32-37
17089-00	47-17	17962-04	14-54	19392-12	18-11	20193-07	32-16
17089-00	47-47	17969-09	37-1	19392-13	18-11	20193-08	32-17
17089-00	48-12	17984-05	38-8	19402-00	18-45	20193-09	32-18
17164-04	24-15	17984-08	38-9	19438-04	45-5	20193-10	32-19
17203-02	44-6	17984-09	38-10	19455-00	18-12	20193-11	32-20
17203-03	44-6	17984-14	38-78	19460-00	19-36	20193-12	32-21
17203-03	44-15	18081-00	25-26	19513-10	25-3	20193-14	32-30
17315-00	6-7	18219-02	37-2	19513-14	43-5	20193-15	32-29
17315-00	8A-16a	18316-02	45-43	19513-16	43-6	20193-16	32-28
17316-00	6-22	18318-00	18-25	19513-24	37-5	20193-17	32-27
17316-00	8A-35	18318-00	18A-9	19513-32	19-8	20193-18	32-26
17317-00	36-12	18329-02	41-7	19513-37	2-8	20193-19	32-25
17318-03	36-11	18359-00	16-4	19513-37	46-38	20193-24	32-24
17528-33	38-6	18359-00	16A-3	19513-39	26-29	20193-25	32-5
17555-00	41-90	18418-02	37-31	19513-56	25-65	20193-28	32-6
17555-00	42-25	18418-02	41-114	19513-59	38-114	20193-29	32-22
17566-02	41-86	18457-00	2-33	19513-61	47-26	20193-31	32-37
17566-02	42-16	18622-00	35-3	19513-63	37-32	20193-41	32-23
17604-14	42-29	18774-00	42A-21	19513-75	21-18c	20195-00	31-4
17604-19	42-2	18794-02	19-5	19513-76	47-35a	20197-00	32-13
17604-21	41-5	18842-00	18-26	19530-00	11B-10	20198-00	32-14
17604-24	41-84	18842-00	18A-10	19540-06	14-5	20204-00	31-34
17667-00	12-62a	18842-02	18-27	19540-09	14-5	20205-00	31-34
17752-03	41-6	18968-00	18-5	19541-02	14-9	20207-11	31-41
17766-03	30-3	18968-00	18A-15	19542-02	14-10	20208-08	31-41
17766-03	30-5	18968-00	18A-31	19543-02	14-6	20211-00	3-41
17766-04	30-5	18968-00	18B-4	19697-03	14-12	20213-00	3-40
17766-44	30-4	18994-00	15-39	19697-03	14A-25	20234-00	2-36
17766-71	25-37	18994-06	15A-41	19697-06	14-12	20234-00	3-36
17766-73	25-37	18996-00	19-7	19697-06	14A-25	20234-01	2-36
17766-75	38-7	19007-02	14-60	19795-00	31-10	20234-01	3-36
17766-77	30-4	19047-04	40-25	19795-00	31-20	20234-02	3-48
17766-77	30A-1	19047-06	40-25	19802-05	23A-1	20234-03	3-48
17766-77	30A-3	19051-00	40-27	19802-05	23B-1	20234-04	3-47
17766-78	30A-2	19063-02	17-3	19802-05	23C-1	20234-05	3-47
17766-79	30A-3	19156-14	40-23	19807-00	41-8	20234-06	3-50
17766-80	30A-2	19156-15	40-23	19857-00	42B-3	20234-07	3-50
17766-80	30A-4	19161-00	15B-7	19871-00	21-26	20234-08	3-52
17766-92	30-3	19286-00	41-24	19885-00	51-1	20234-09	3-52
17794-00	28-7	19286-00	41-59	19892-00	22-2	20234-10	3-51
17807-00	41-54	19304-00	18-19	19893-00	22-3	20234-11	3-51
17807-00	41-64	19331-02	37-4	19927-02	15-11	20234-15	3-43
17807-00	42-9	19336-00	18-13	19927-03	15-11	20234-16	3-39
17807-00	42-48	19336-00	18-14	19927-08	15A-5	20234-17	3-37
17807-00	42-48	19336-00	18A-24	19927-09	15A-5	20234-18	3-49
17807-00	46-2	19336-00	18A-40	19927-10	15A-5	20234-19	3-46
17852-02	37-32	19336-00	18B-11	19940-00	37-33	20234-22	3-54
17852-03	37-32	19336-01	18-13	19941-00	17-2	20234-27	2-36
17860-00	19-3	19336-01	18-14	19943-27	18-36	20234-27	3-36
17862-02	19-4	19336-01	18A-24	19943-28	18-36	20234-40	3-42
17866-04	7-8	19336-01	18A-40	19943-29	18-36	20234-42	3-38
17870-08	13-15	19336-01	18B-11	19950-00	14-105	20234-43	2-36
17871-06	13-16	19354-00	7-9	20183-03	33-21a	20234-43	3-36

## PIPER PARTS CATALOG

Part Number	Fig. and Index	Part Number	Fig. and Index	Part Number	Fig. and Index	Part Number	Fig. and Index
20234-44	2-36	20284-00	5-29	20340-01	5-17	20423-00	12-75
20234-44	3-36	20284-01	5-29	20345-00	2-34	20424-00	12-76
20235-02	4-4	20286-04	39-24	20345-00	42-41	20425-00	12-77
20235-03	4-5	20286-05	39-24	20346-00	4-15	20426-00	12-78
20235-04	4-57	20287-00	39-25	20347-02	2-35	20428-00	12-51
20235-05	4-57	20287-01	39-25	20347-02	42-42	20428-01	12-51
20235-06	4-5	20288-00	5-27	20348-00	2-16	20432-00	12-21
20236-00	4-6	20288-01	5-27	20348-01	2-16	20433-00	2-17
20236-01	4-6	20293-00	5-34	20351-08	5-45	20434-00	11B-38
20237-02	4-56	20294-00	5-30	20351-09	5-45	20435-00	11B-39
20237-03	4-56	20296-07	4-10	20357-06	4-38	20437-04	45-20
20237-04	4-56	20296-08	4-10	20357-07	4-38	20437-07	45-22
20237-05	4-56	20303-08	4-35	20357-08	4-37	20437-08	45-21
20237-06	4-56	20303-09	4-35	20357-09	4-37	20438-02	45-23
20242-00	5-33	20303-16	4-33	20357-10	4-36	20438-04	45-24
20242-01	5-33	20303-17	4-33	20357-11	4-36	20442-02	11-10
20247-00	5-43	20303-18	4-34	20358-00	4-65	20442-02	11A-10
20252-05	4-11	20303-19	4-34	20358-01	4-65	20442-03	11-11
20252-06	4-11	20303-22	4-33	20359-00	4-66	20442-03	11A-11
20257-02	32-3	20303-23	4-33	20360-14	5-49	20443-00	10-23
20257-03	32-4	20304-30	3-20	20360-15	5-49	20443-01	10-23
20262-00	5-28	20307-06	4-32	20366-00	39-5	20445-00	11-43
20262-01	5-28	20307-07	4-32	20366-00	40-11	20445-00	11A-46
20263-04	5-46	20307-08	4-31	20366-02	39-15	20447-04	2-52
20263-05	5-46	20307-09	4-31	20366-02	40-2	20447-05	2-52
20266-02	5-7	20307-10	4-30	20370-00	6-4	20447-07	2-52
20266-03	5-7	20307-11	4-30	20370-00	6-23	20447-08	2-52
20267-02	5-48	20307-14	4-30	20377-45	6-1	20452-00	12-22
20269-00	5-20	20307-15	4-30	20377-46	6-1	20453-00	12-23
20269-01	5-20	20309-00	5-23	20377-55	6-17	20453-01	12-23
20272-06	2-9	20309-00	45-17	20377-56	6-17	20455-00	11-2
20272-07	2-9	20309-01	5-23	20377-57	6-6	20455-00	11A-2
20272-10	4-7	20310-02	4-14	20377-58	6-6	20455-01	11-2
20272-11	4-7	20310-03	4-14	20379-00	34-4	20455-01	11A-2
20273-06	4-45	20310-04	5-24	20379-01	34-4	20457-00	9-3
20273-07	4-45	20310-05	5-24	20386-02	4-3	20457-00	9A-7
20273-10	4-46	20311-00	2-12	20386-03	4-55	20462-00	43-2a
20273-11	4-46	20313-00	2-13	20393-00	25-7	20462-02	43-2a
20273-16	4-44	20314-00	2-14	20394-00	25-7	20462-03	43-2a
20273-16	4-52	20315-00	2-15	20396-00	4-13	20462-04	43-2a
20273-17	4-44	20315-02	2-15	20397-00	31-37	20469-00	9-4
20273-17	4-52	20318-00	5-21	20409-02	12-53	20475-04	12-56
20273-18	4-53	20318-01	5-21	20409-03	12-53	20476-00	2-19
20273-19	4-53	20342-02	5-15	20410-02	12-54	20476-01	2-19
20273-20	4-47	20324-03	5-15	20410-03	12-54	20477-00	11-4
20273-21	4-47	20325-00	39-2	20411-00	11-48	20477-00	11A-4
20274-06	5-26	20326-00	39-3	20411-00	11A-48	20479-07	12-58
20274-07	5-26	20327-03	39-8	20411-01	11-48	20488-02	44-7
20274-08	2-10	20328-02	39-4	20411-01	11A-48	20488-03	44-7
20274-09	2-10	20329-10	39-1	20413-00	12-70	20489-06	2-20
20275-04	5-25	20330-00	39-26	20414-00	12-71	20489-07	2-20
20275-05	5-25	20330-00	40-35	20415-00	12-72	20496-00	11-31
20275-06	4-8	20330-02	39-26	20416-00	12-73	20497-00	11-12
20275-07	4-8	20330-02	40-35	20419-00	12-45	20497-00	11A-12
20282-00	4-9	20332-00	39-27	20419-01	12-45	20498-00	11-13
20282-03	4-9	20332-00	40-18	20420-00	12-42	20498-00	11A-13
20283-00	5-22	20333-00	39-12	20420-01	12-42	20500-03	12-9
20283-01	5-22	20340-00	5-17	20422-00	12-74	20500-04	12-14

REVISED, SEPTEMBER 1982

# PIPER PARTS CATALOG

Part Number	Fig. and Index	Part Number	Fig. and Index	Part Number	Fig. and Index	Part Number	Fig. and Index
20500-11	12-61	20554-23	11-35	20600-135	9-8	20649-05	23-42
20500-15	12-13	20554-29	9-20	20600-135	9A-5	20650-05	14-13
20500-26	12-44	20555-02	8-24	20600-136	9-9	20650-07	14-4
20500-27	12-44	20555-02	8A-28	20600-136	9A-5	20658-02	5-19
20500-28	12-41	20557-06	10-13	20601-05	10-29	20666-02	2-32
20500-29	12-41	20557-07	10-13	20603-06	9A-44	20666-02	2-43
20500-31	12-40	20557-08	10-14	20603-08	9A-44	20669-03	16-14
20500-37	12-27	20557-09	10-14	20603-09	9-31	20669-04	16-14
20500-38	12-25	20561-03	9-15	20603-10	9-30	20669-08	16-19
20500-53	12-19	20561-03	9A-14	20603-11	9-24	20669-09	16-16
20504-02	11-14	20570-07	10-8	20603-11	9A-15	20669-10	16-16
20504-02	11A-14	20570-08	10-8	20603-12	9A-45	20672-00	16-9
20504-03	11-14	20575-00	15-4	20603-15	9-30	20672-01	16-8
20504-03	11A-14	20587-02	2-59	20603-16	9-31	20672-02	16-33
20504-04	11A-14	20588-05	11B-40	20603-21	9-30	20676-00	16-10
20504-04	11-15	20588-06	11B-40	20603-22	9A-16	20676-03	16A-9
20504-04	11A-15	20588-10	11B-41	20604-10	10-55	20677-05	16-1
20505-02	11-16	20588-12	11B-1	20604-12	10-55	20677-05	16A-5
20505-02	11A-16	20588-15	11B-43	20610-02	9-39	20677-06	16-7
20505-03	11-17	20590-00	14-7	20610-02	9A-47	20677-06	16A-6
20505-03	11A-17	20593-00	2-24	20610-03	9-19	20677-07	16-7
20507-00	9-11	20599-00	14-8	20610-03	9A-18	20677-07	16A-6
20507-01	9-11	20600-09	8-4	20610-04	9-17	20677-08	16-5
20510-00	18-39	20600-09	8A-4	20610-04	9A-19	20677-08	16A-4
20512-00	15-1	20600-15	8-12	20610-05	9-18	20677-09	16-1
20512-00	15A-7	20600-15	8A-10	20610-05	9A-20	20677-09	16A-
20515-00	11-5	20600-16	8-12	20610-06	11B-2	20677-10	16-1
20515-00	11A-5	20600-16	8A-10	20610-07	11B-2	20677-10	16A-1
20516-00	11-5	20600-21	10-22	20610-13	9-19	20677-13	16A-1
20516-00	11A-5	20600-21	11-42	20612-04	10-54	20677-14	16A-1
20517-00	18-40	20600-22	11-44	20612-05	10-54	20707-06	34-5
20523-00	15-2	20600-23	11-44	20613-03	10-50	20707-07	34-5
20523-00	15A-9	20600-24	9-5	20613-04	10-50	20713-00	31-15
20524-07	13-30	20600-24	9A-3	20615-04	8-17	20715-00	16-2
20527-00	2-21	20600-24	9A-4	20615-04	8A-17	20715-00	16A-2
20527-01	2-21	20600-34	9-6	20616-04	11-39	20719-00	16-3
20534-00	47-5	20600-38	9A-2	20616-04	11A-38	20719-01	16-3
20534-00	48-22	20600-50	10-25	20616-05	11-39	20720-00	2-25
20534-00	48-28	20600-51	10-25	20616-05	11A-38	20721-00	2-26
20535-00	2-22	20600-56	11-26	20616-06	11-47	20729-04	33-21
20535-01	2-22	20600-56	11A-27	20616-06	11A-47	20735-00	26-11
20537-00	15-3	20600-58	11-27	20616-07	11-47	20736-02	26-27
20539-07	9-36	20600-58	11A-28	20616-07	11A-47	20737-02	26-4
20539-07	9A-11	20600-59	11-27	20617-06	9-41	20737-02	26-21
20539-24	9-34	20600-59	11A-28	20617-06	9A-35	20737-02	26-53
20546-04	11-6	20600-62	10-17	20617-07	9-40	20737-04	26-9
20546-05	11-6	20600-63	10-17	20617-07	9A-48	20737-08	25-55
20548-02	12-28	20600-70	11A-30	20629-00	17-17	20737-13	25-17
20548-03	12-28	20600-75	11-24	20629-01	17-18	20737-14	25-18
20548-04	12-29	20600-75	11A-34	20635-02	15-69	20737-16	26-5
20548-05	12-29	20600-87	8-5	20635-02	15A-71	20742-00	17-16
20554-02	11-8	20600-89	9-7	20635-03	15-70	20752-08	26-2
20554-05	11-9	20600-96	9A-36	20635-03	15A-66	20752-09	26-2
20554-12	11-18	20600-99	10-58	20635-04	15-71	20754-02	26-36
20554-12	11A-18	20600-101	11-28	20635-04	15A-67	20757-00	25-11
20554-16	11-19	20600-125	9A-41	20635-05	15A-67	20757-01	25-11
20554-16	11A-19	20600-131	11-29	20646-00	11-45	20767-00	25-54
20554-17	11-19	20600-132	11-29	20649-03	23-30	20767-03	25-54
20554-17	11A-19						

# PIPER PARTS CATALOG

Part Number	Fig. and Index
20767-04	25-54
20774-00	12-66
20774-01	12-66
20778-00	12-67
20782-02	26-13
20784-00	26-37
20785-02	26-35
20787-00	26-22
20790-02	26-20
20800-00	48-16
20803-02	24-16
20814-00	24-19
20815-00	24-21
20819-00	24-23
20821-02	24-28
20824-03	25-36
20824-04	25-36
20825-00	24-8
20825-00	25-22
20828-00	25-74
20830-00	16-26
20830-00	16A-39
20834-04	48-17
20838-00	48-1
20840-03	48-14
20844-00	25-23
20845-00	25-25
20846-06	25-28
20846-07	25-28
20847-98	49-17
20847-98	51-3
20854-00	24-10
20854-00	25-29
20868-00	18-32
20869-00	18-33
20873-03	44-1
20873-05	44-1
20882-08	44-10
20899-02	39-13
20899-03	39-13
20900-00	9-21
20902-00	9-27
20903-00	48-35
20904-00	9-28
20905-00	48-38
20906-00	9-29
20906-01	9-29
20907-00	48-36
20908-00	48-31
20919-00	118-56
20920-00	118-57
20923-11	17-7
20924-00	118-3
20928-00	43-7
20929-00	118-4
20930-00	118-5
20930-01	118-5
20935-00	118-6

Part Number	Fig. and Index
20936-00	118-7
20938-00	43-8
20943-03	45-1
20943-05	45-2
20943-06	45-2
20944-08	46-37
20945-03	45-61
20945-05	45-61
20945-06	45-61
20946-00	48-23
20952-00	29-44
20953-00	29-43
20954-00	10-15b
20956-00	43-18
20957-00	43-19
20963-00	43-20
20965-00	43-1
20965-07	43-1
20965-10	43-1
20966-00	39-17
20966-02	40-3
20975-00	43-21
20975-03	43-21
20977-03	9A-17
20977-06	9A-21
20983-00	2-29
20983-01	2-29
20984-00	2-30
20984-01	2-30
20988-00	12-50
20995-00	43-9
20996-00	43-37
20997-00	43-10
20999-00	43-24
21001-00	43-11
21007-00	15-6
21007-01	15-6
21012-02	29-7
21012-03	29-8
21013-02	29-9
21017-00	30-9
21025-04	16-12
21025-04	16A-11
21027-00	16-11
21027-00	16A-10
21033-00	29-14
21038-07	29-29
21041-00	29-15
21048-00	45-4
21048-08	45-4
21060-00	25-30
21061-00	41-11
21061-00	42-6
21063-00	29-17
21065-12	28-10
21066-00	28-8
21067-03	28-4
21072-00	5-50

Part Number	Fig. and Index
21072-01	5-50
21080-00	29-28
21083-03	29-27
21087-00	29-13
21093-02	48-24
21098-00	30-1
21100-00	25-31
21103-00	25-60
21103-01	25-60
21104-00	25-61
21104-01	25-61
21109-03	29-37
21155-03	10-34
21173-00	26-5c
21174-00	26-5d
21175-00	26-5e
21175-01	26-5e
21178-00	25-35
21206-00	25-21
21206-01	25-21
21215-00	26-46
21219-00	25-78
21220-00	25-77
21221-00	25-76
21225-00	13-20
21226-00	35-56
21250-00	11A-55
21250-01	11A-55
21265-00	3-44
21267-00	2-31
21267-01	2-31
21270-00	3-45
21286-00	29-31
21290-02	5-48
21299-00	42-46
21301-00	42-45
21307-00	9A-23
21328-02	11-46
21328-03	11-46
21336-00	15-9
21336-00	15A-10
21373-00	15-10
21373-00	15A-32
21373-01	15-10
21373-01	15A-32
21377-00	44-4
21383-00	47-8
21389-03	47-10
21401-00	46-11
21404-00	46-13
21415-00	29-33
21415-00	46-8
21418-00	29-34
21418-02	46-9
21419-00	46-12
21420-04	32-7
21420-05	32-7
21450-00	43-36

Part Number	Fig. and Index
21454-00	43-12
21469-00	43-4
21470-00	43-22
21471-00	118-8
21510-02	31-18
21524-02	42-28
21524-03	41-83
21525-02	15-12
21525-02	15A-33
21525-03	15-12
21525-03	15A-33
21552-00	2-60
21552-01	2-60
21556-00	32-2
21558-00	13-2
21558-04	13-2
21560-00	9-23
21560-01	9-23
21560-02	9A-22
21560-03	9A-22
21574-00	19-13
21587-00	26-50
21588-00	26-5a
21619-00	43-32
21620-00	43-28
21639-18	15-16
21639-19	15-16
21639-20	15-17
21698-00	24-29
21701-03	24-11
21701-05	24-11
21704-00	29-26
21706-00	26-10
21707-00	26-52
21708-00	24-49
21709-00	26-56
21710-00	26-40
21712-02	26-36
21715-04	26-6
21715-06	26-6
21719-11	26-34
21725-00	24-1
21741-00	16-32
21741-00	16A-38
21741-02	16-32
21741-02	16A-38
21747-03	9-10
21747-04	9-10
21748-00	9-22
21760-00	10-15a
21782-00	49-13
21782-00	51-2
21817-10	39-7
21820-02	24-39
21820-03	24-39
21820-04	24-39
21824-00	15-21
21824-00	15A-34



## PIPER PARTS CATALOG

Part Number	Fig. and Index	Part Number	Fig. and Index	Part Number	Fig. and Index	Part Number	Fig. and Index
21829-00	26-14	22103-02	41-14	22178-03	4-59	22272-09	10-18
21829-01	26-14	22103-02	41-15	22178-04	4-60	22272-10	10-18
21830-00	24-30	22103-02	41-16	22178-05	4-60	22274-02	40-16
21830-01	24-30	22103-02	41-17	22178-06	4-61	22274-03	40-16
21831-02	24-50	22103-02	41-18	22178-07	4-61	22274-04	40-17
21831-03	26-57	22104-02	41-17	22183-00	11B-58	22274-05	40-17
21831-04	26-55	22104-03	37-8	22184-00	11B-59	22281-03	38-14
21854-00	29-22	22104-03	41-16	22189-00	12-32	22287-00	19-28
21855-00	29-25	22104-06	41-13	22190-00	12-33	22287-00	19-67
21865-00	12-31	22104-06	41-15	22191-03	11B-21	22288-00	30-12
21865-01	12-31	22104-06	41-18	22197-00	41-19	22289-00	15-35
21868-00	24-36	22104-07	37-9	22198-00	41-20	22289-00	15-45
21879-00	15-64	22104-07	41-14	22198-01	41-20	22295-00	19-9
21879-00	15A-61	22104-07	41-16	22200-00	11B-35	22302-00	4-63
21885-03	39-28	22104-07	41-17	22201-00	30-56	22302-01	4-63
21914-02	16-15	22104-08	41-12	22201-01	30-57	22313-00	30-13
21918-00	2-11	22105-02	41-12	22205-00	44-12	22320-00	30-14
21918-01	2-11	22105-02	41-17	22207-00	44-9	22321-00	30-15
21919-08	2-38	22105-03	37-10	22208-02	11B-25	22323-00	30-2
21919-09	2-38	22105-03	41-16	22208-03	11B-26	22334-00	15-36
21922-00	9-2	22105-05	37-11	22208-04	11B-27	22334-00	15-46
21922-01	9-2	22105-05	41-14	22209-00	11B-28	22334-00	15A-18
21928-00	9-14	22105-05	41-17	22211-04	11B-60	22334-00	15A-25
21929-00	9-32	22105-05	55-4	22211-06	11B-60	22340-03	15-7
21930-00	9-35	22105-06	37-12	22213-00	11B-61	22341-00	14-25
21953-00	10-35	22105-07	41-13	22213-04	11B-61	22344-00	14-55
21953-01	10-35	22105-07	41-15	22223-03	11B-29	22344-00	14A-45
21955-02	18-31	22105-07	41-18	22226-00	30-55	22345-00	14-56
21955-02	18A-5	22114-00	23-2	22232-03	10-22	22352-00	19-14
21955-03	18-30	22117-00	8-29	22232-03	11-42	22353-00	19-11
21955-03	18A-6	22117-00	8A-33	22233-02	12-5	22354-00	19-12
21955-04	18-29	22122-00	8-30	22233-04	12-24	22362-03	23-3
21955-04	18A-5	22123-03	15-23	22233-05	12-24	22362-05	23-3
21955-05	18-28	22157-02	4-49	22235-00	12-34	22363-00	19-10
21955-05	18A-6	22157-02	4-50	22236-00	12-35	22369-02	42-17
21995-05	17-44	22157-03	4-48	22239-00	44-11	22369-03	42-18
21995-06	17-44	22157-03	4-51	22240-04	12-36	22369-04	42-19
21995-08	17-44	22157-04	4-48	22240-05	12-36	22369-11	41-89
21995-09	17-44	22157-04	4-51	22246-00	12-37	22369-14	38-108
21996-00	44-14	22157-05	4-49	22248-00	42A-1	22369-15	38-108
21998-00	43-15	22157-05	4-50	22249-00	30-58	22369-24	19-2
22037-02	40-8	22158-02	4-23	22249-03	30-58	22369-27	41-88
22037-03	40-8	22158-03	4-23	22250-00	30-58	22369-28	21-1
22042-00	45-15	22158-08	4-24	22250-03	30-58	22369-31	23B-62
22048-00	30-59	22158-09	4-24	22257-00	8A-27	22369-31	23C-60
22050-00	11B-11	22158-10	4-22	22257-00	10-36	22374-02	19-15
22054-00	11B-24	22158-11	4-22	22259-07	11B-44	22374-03	19-15
22055-00	14-14	22158-14	4-24	22260-00	38-12	22407-00	42-15
22056-00	14-58	22158-15	4-24	22263-03	12-79	22421-00	9A-40
22056-03	14-58	22162-02	4-26	22263-04	12-80	22433-00	19-29
22066-00	24-31	22162-03	4-26	22267-00	38-13	22448-00	15-37
22066-00	24-32	22162-08	4-27	22268-00	4-62	22448-00	15-47
22073-00	42-14	22162-09	4-27	22268-01	4-62	22448-00	15A-21
22090-00	8-26	22162-10	4-28	22270-00	30A-12	22448-00	15A-27
22090-00	8A-32	22162-11	4-28	22270-03	30-11	22451-04	40-1
22103-02	37-7	22162-14	4-27	22271-00	40-15	22451-05	40-1
22103-02	41-12	22162-15	4-27	22271-01	40-15	22452-00	15-56
22103-02	41-13	22178-02	4-59	22272-09	10-18	22452-00	15A-12

REVISED: SEPTEMBER 1982

## PIPER PARTS CATALOG

Part Number	Fig. and Index	Part Number	Fig. and Index	Part Number	Fig. and Index	Part Number	Fig. and Index
22454-00	15-24	22562-00	11A-3	22618-03	11A-36	22695-00	46-6
22454-00	15A-11	22562-01	11-3	22618-04	11-36	22695-03	46-6
22454-02	15A-11	22562-01	11A-3	22618-04	11A-35	22697-00	46-30
22460-00	19-32	22562-02	14-26	22618-05	11-38	22697-07	46-30
22462-02	14-26	22564-00	11B-36	22618-05	11A-37	22697-10	46-30
22462-02	14A-31	22565-03	9-26	22618-08	11A-35	22699-00	2-39
22470-06	19-30	22566-00	8-3	22620-00	8-21	22699-00	3-1
22470-07	19-30	22566-00	9-1	22620-00	11-1	22699-01	2-39
22470-12	19-30	22566-06	8-6	22620-04	11-30	22699-01	3-1
22470-15	19-30	22570-00	17A-2	22620-05	11-30	22699-02	3-21
22472-06	19-31	22572-10	10-32	22620-06	11-24	22699-03	3-23
22472-08	19-31	22572-11	10-32	22620-08	11-34	22699-08	3-31
22472-09	19-31	22572-12	10-32a	22620-08	11A-33	22699-09	3-31
22472-15	19-31	22572-13	10-32a	22620-09	11-34	22699-10	3-30
22472-20	19-31	22573-12	12-2	22620-09	11A-33	22699-11	3-30
22502-20	21-35	22573-13	12-3	22620-10	11-25	22699-12	3-29
22502-27	19-16	22573-17	12-6	22620-11	11-25	22699-13	3-29
22502-28	19-17	22573-18	12-7	22620-14	11-32	22699-14	3-28
22502-29	19-18	22573-19	12-8	22620-15	11-32	22699-17	3-24
22502-30	19-19	22573-20	12-4	22620-21	8-21	22699-19	3-26
22502-30	21-4	22573-21	12-10	22620-21	11-1	22699-29	3-35
22502-31	19-20	22573-22	12-11	22620-23	11-30	22700-02	6-15
22502-32	35-4	22573-23	12-12	22620-24	11-30	22700-03	6-15
22502-33	35-5	22574-02	12-46	22627-00	46-45	22700-12	6-14
22502-39	21-5	22574-03	12-47	22628-00	13-38	22700-13	6-14
22502-40	21-6	22574-04	12-39	22629-02	10-16	22700-14	6-13
22502-41	21-7	22574-07	12-39	22631-02	10-15	22700-15	6-13
22503-00	38-15	22574-08	12-43	22641-00	17-22	22704-00	3-8
22512-00	25-19	22574-11	12-38	22649-00	4-64	22704-00	3-9
22513-00	25-15	22576-00	11B-45	22653-00	17-19	22704-01	3-8
22513-01	25-15	22576-01	11B-45	22654-00	3-2	22704-01	3-9
22518-00	31-2	22577-00	25-62	22654-01	3-2	22705-02	3-3
22518-01	31-2	22582-04	9-34	22655-05	31-32	22705-02	3-10
22520-02	8-25	22582-07	9-37	22655-07	31-33	22705-03	3-3
22520-02	8A-31	22586-00	11-50	22659-02	3-4	22705-03	3-10
22523-00	31-1	22587-00	11-41	22659-03	3-5	22705-05	3-4
22523-00	32-1	22587-00	11A-44	22659-04	3-5	22714-00	3-17
22523-01	31-1	22600-02	11-40	22659-06	3-6a	22714-00	3-19
22523-01	32-1	22600-03	11-40	22659-06	3-7	22714-00	3-22
22523-02	32-11	22604-00	11-33	22659-07	3-6	22714-00	3-25
22523-03	32-12	22604-01	11-33	22659-07	3-6a	22726-00	3-27
22523-04	32-9	22606-03	11-8	22659-07	3-7	22733-02	5-32
22523-05	32-9	22606-05	11-7	22663-00	42-10	22733-03	5-32
22523-06	32-10	22607-03	8-15	22663-00	46-3	22733-04	5-37
22523-07	32-10	22607-05	8-14	22667-00	3-14	22733-05	5-37
22523-08	32-15	22607-09	8-16	22668-02	3-13	22733-06	5-36
22523-09	32-15	22607-16	10-51	22668-02	3-35a	22733-07	5-36
22546-00	51-8	22607-22	10-51	22668-03	3-15	22733-08	5-40
22546-02	51-8	22607-23	8-16	22668-06	3-33	22733-09	5-40
22549-00	12-62	22608-00	16A-48	22668-07	3-32	22740-00	46-59
22549-01	12-62	22609-00	16-24	22669-00	3-12	22748-00	45-36
22550-00	12-48	22609-00	16A-42	22675-02	9-33	22748-01	45-36
22550-01	12-48	22615-00	17-9	22676-00	17-23	22751-02	6-20
22552-02	16-49	22616-00	16-25	22679-04	17-32	22751-03	6-20
22552-03	16-50	22616-00	16A-41	22683-00	3-11	22751-04	6-21
22555-00	12-69	22618-02	11-37	22688-00	46-4	22751-05	6-21
22556-00	16-48	22618-02	11A-36	22694-00	46-5	22751-06	6-19
22562-00	11-3	22618-03	11-37	22694-03	46-5	22751-07	6-19

REVISED: SEPTEMBER 1982

## PIPER PARTS CATALOG

Part Number	Fig. and Index	Part Number	Fig. and Index	Part Number	Fig. and Index	Part Number	Fig. and Index
22768-00	5-41	22886-02	46-31	23090-95	18-1	23274-13	18-20
22775-00	26-33	22886-03	46-32	23090-96	18-1	23274-14	18-20
22780-00	5-39	22886-04	46-32	23090-97	18-1	23274-15	18-20
22783-02	5-42	22887-00	48-4	23090-98	18-1	23274-16	18-20
22783-03	5-42	22902-00	39-23	23090-99	18-1	23274-17	18-20
22785-00	26-25	22902-01	39-23	23090-100	18-1	23274-18	18-20
22787-00	5-47	22903-00	12-55	23090-101	18-1	23274-19	18-20
22787-01	5-47	22904-00	12-52	23090-102	18-1	23274-20	18-20
22789-00	5-10	22943-00	25-64	23090-103	18-4	23275-14	18-21
22789-01	5-10	22966-02	45-62	23090-104	18-4	23275-15	18-21
22789-04	5-11	22966-03	45-63	23090-105	18-4	23275-16	18-21
22789-05	5-11	22968-00	45-11	23090-106	18-4	23275-17	18-21
22793-00	46-44	22982-02	6-9	23090-107	18-4	23275-18	18-21
22801-00	5-12	22982-02	40-24	23090-108	18-4	23275-19	18-21
22801-01	5-12	22984-00	28-9	23090-109	18-4	23275-20	18-21
22803-00	5-3	22984-01	28-9	23090-110	18-4	23275-21	18-21
22803-01	5-3	22998-02	6-25	23090-115	18-2	23276-16	15-30
22803-04	5-3	22998-03	6-25	23090-116	18-2	23276-18	15-30
22803-05	5-3	23013-00	46-7	23090-117	18-2	23277-12	15-40
22810-00	24-13	23040-08	15-27	23090-118	18-2	23277-19	15-40
22810-00	26-1	23040-09	15-27	23090-119	18-2	23278-05	15-50
22810-03	24-13	23040-12	15A-35	23090-120	18-2	23278-12	15-50
22810-03	26-1	23040-13	15A-35	23090-121	18-2	23283-00	9-25
22810-04	24-13	23040-14	15A-35	23090-122	18-2	23283-00	9A-6
22810-04	26-1	23042-00	29-32	23091-00	38-47	23283-01	9-25
22825-00	25-66	23042-00	46-10	23103-00	29-2	23283-01	9A-6
22825-01	25-66	23046-00	46-14	23109-00	24-25	23284-00	9-12
22833-02	25-71	23054-04	6-16	23117-00	46-49	23284-00	9A-9
22833-02	26-1	23054-05	6-16	23128-02	16-17	23285-00	9-13
22833-03	25-71	23056-02	8-11	23128-03	16-18	23285-00	9A-9
22833-03	26-1	23056-02	8A-12	23128-04	16-17	23287-00	16-38
22836-00	12-17	23056-03	8-13	23148-00	51-9	23287-01	16-38
22839-00	17-24	23087-00	3-55	23165-02	47-48	23288-00	9A-46
22840-02	17-20	23087-00	46-34	23167-00	14-29	23289-00	16-39
22846-00	40-10	23090-38	18-1	23167-00	14A-44	23289-01	16-39
22852-00	46-61	23090-39	18-1	23179-00	45-34	23290-00	16-40
22853-00	46-62	23090-40	18-4	23183-00	11A-67	23290-01	16-40
22854-00	46-63	23090-41	18-4	23183-00	17A-8	23291-02	16-43
22855-00	46-60	23090-46	18-1	23183-00	41-67a	23291-03	16-43
22856-02	41-36	23090-47	18-1	23184-00	17A-1	23291-04	16-44
22856-02	49-17	23090-48	18-4	23195-10	38-16	23291-05	16-44
22856-02	51-4	23090-49	18-4	23196-00	3-34	23293-02	16-45
22856-03	41-37	23090-50	18-1	23210-02	42A-5	23293-02	16A-24
22858-03	42A-2	23090-51	18-1	23225-00	46-1	23293-03	16-46
22858-05	42A-2	23090-52	18-4	23226-00	46-27	23293-03	16A-25
22858-06	42A-2	23090-53	18-4	23227-03	5-38	23294-02	17-6
22860-02	17-33	23090-58	18-1	23229-00	42A-6	23294-03	17-6
22864-02	48-18	23090-59	18-1	23230-00	38-17	23295-03	16-47
22865-00	12-18	23090-60	18-4	23240-00	17-39	23297-02	16-41
22865-01	12-18	23090-61	18-4	23243-03	47-15	23297-03	16-42
22866-00	5-16	23090-62	18-2	23252-06	18-19a	23297-04	16-42
22866-01	5-16	23090-63	18-2	23252-08	18-19a	23298-10	15-20
22877-00	12-68	23090-69	18-2	23252-10	18-19a	23298-11	15-20
22878-00	46-68	23090-70	18-2	23252-12	18-19a	23298-29	15-20
22880-00	31-36	23090-78	18-2	23269-03	15-28	23298-32	15-20
22882-00	31-35	23090-79	18-2	23269-07	15A-38	23302-00	15-49
22883-00	12-49	23090-93	18-2	23270-09	17-34	23302-00	16A-33
22883-01	12-49	23090-94	18-2	23270-14	17-34	23303-00	15-55

## PIPER PARTS CATALOG

Part Number	Fig. and Index	Part Number	Fig. and Index	Part Number	Fig. and Index	Part Number	Fig. and Index
23303-00	16A-34	23416-00	34-8	23464-01	39-30	23520-01	6-11
23305-11	15-57	23417-00	34-9	23465-00	5-13	23521-00	6-12
23305-18	15-58	23418-00	34-10	23465-01	5-13	23521-01	6-12
23305-34	15-57	23419-00	34-11	23469-12	18-38	23523-02	4-21
23305-35	15-58	23420-00	34-12	23469-13	18-38	23523-03	4-21
23305-36	15-57	23426-02	39-14	23469-14	18-38	23523-06	4-20
23305-37	15-58	23426-03	39-14	23474-00	6-24	23523-07	4-20
23305-42	15-57	23427-00	34-13	23475-06	5-44	23526-00	6-36
23305-43	15-58	23428-00	34-14	23475-07	5-44	23526-01	6-36
23305-44	15-57	23431-00	34-21	23476-00	5-5	23527-00	40-6
23305-45	15-58	23433-00	34-22	23476-01	5-5	23527-01	40-6
23305-52	15A-39	23435-02	34-19	23478-00	39-29	23528-00	36-41
23308-02	17-5	23435-03	34-20	23478-01	39-29	23528-01	36-41
23308-03	17-5	23436-00	33-5	23479-00	5-4	23529-00	40-20
23308-06	17-5	23437-00	33-4	23479-01	5-4	23529-01	40-20
23313-02	16-20	23437-01	33-4	23479-02	5-9	23529-02	40-20
23313-03	16-20	23438-00	34-15	23479-03	5-9	23529-03	40-20
23313-05	16-20	23440-00	34-16	23479-04	5-8	23529-04	40-20
23313-06	16-20	23444-00	34-18	23479-05	5-8	23529-05	40-20
23314-02	16-21	23445-00	31-19	23480-02	5-14	23530-02	4-19
23314-03	16-21	23446-03	34-3	23480-03	5-14	23530-03	4-19
23314-06	16A-20	23446-04	34-2	23480-04	5-1	23530-06	4-18
23314-07	16A-20	23446-05	34-2	23480-05	5-1	23530-07	4-18
23315-02	16-22	23446-06	31-5	23480-08	5-1	23532-00	36-42
23315-03	16-22	23446-06	34-1	23480-09	5-1	23532-01	36-42
23315-05	16-22	23446-07	31-5	23484-00	36-34	23533-00	36-43
23315-06	16-22	23446-07	34-1	23485-00	36-36	23533-01	36-43
23319-00	38-18	23446-08	31-5	23485-01	36-36	23534-00	4-54
23320-02	15-18	23446-08	34-1	23486-00	36-37	23534-01	4-54
23320-04	15-18	23447-02	33-14	23486-01	36-37	23536-00	40-22
23320-05	15-18	23447-03	33-15	23487-02	4-42	23536-01	40-22
23321-00	15-19	23447-04	33-16	23487-03	4-42	23539-00	36-28
23322-00	43-38	23447-05	33-17	23488-02	4-17	23539-01	36-28
23323-00	43-23	23447-06	33-18	23488-03	4-17	23540-02	6-34
23336-00	18-22	23447-07	33-19	23488-06	4-16	23540-03	6-34
23336-01	18-22	23447-08	33-20	23488-07	4-16	23540-04	6-27
23339-04	21-8	23447-09	33-2	23494-00	6-35	23540-05	6-27
23346-00	17-10	23447-10	33-3	23495-00	36-38	23540-12	6-28
23346-04	17-10	23447-15	31-11	23495-01	36-38	23540-13	6-28
23347-00	42A-7	23447-15	33-1	23496-00	36-39	23540-14	6-26
23347-00	42B-8	23447-16	31-11	23496-01	36-39	23540-15	6-26
23349-00	17-12	23447-16	33-1	23497-00	4-29	23540-18	6-33
23349-02	17-12	23448-00	33-13	23497-01	4-29	23540-19	6-33
23350-03	17-4	23449-00	34-17	23505-00	5-2	23540-20	6-30
23353-00	17-11	23452-00	48-26	23505-01	5-2	23540-21	6-30
23353-04	17-11	23452-01	48-26	23506-00	4-40	23540-24	36-57
23354-00	17-13	23456-00	5-18	23506-01	4-40	23540-25	36-29
23355-00	17-45	23456-01	5-18	23508-00	4-2	23540-26	36-29
23356-00	17-40	23463-10	17-46	23508-01	4-2	23542-00	40-9
23360-06	17-15	23463-11	17-46	23512-00	36-28a	23543-02	6-32
23360-09	17-15	23463-12	17-46	23512-01	36-28a	23543-03	6-29
23378-00	14-27	23463-16	15-60	23513-00	36-40	23543-03	6-32
23394-00	43-22a	23463-16	15-61	23513-01	36-40	23545-00	14-28
23398-00	15-26	23463-17	15-60	23514-00	4-25	23545-02	50-22
23398-02	15-26	23463-17	15-61	23514-01	4-25	23546-00	49-15
23400-00	11B-22	23463-18	15-60	23519-00	4-58	23549-00	36-44
23414-00	34-6	23463-18	15-61	23519-01	4-58	23549-01	36-44
23415-00	34-7	23464-00	39-30	23520-00	6-11	23550-00	36-45

## PIPER PARTS CATALOG

Part Number	Fig. and Index	Part Number	Fig. and Index	Part Number	Fig. and Index	Part Number	Fig. and Index
23550-01	36-45	23577-01	36-53	23664-02	11-23	23719-00	7-12
23551-00	4-12	23585-02	31-23	23664-02	11A-23	23728-00	51-15
23551-01	4-12	23585-03	31-23	23665-02	11-23	23733-00	19-23
23552-00	17-36	23593-00	33-6	23665-02	11A-23	23734-00	19-24
23553-00	40-7	23594-00	31-40	23667-00	11B-48	23737-00	37-35
23553-01	40-7	23595-00	33-7	23669-00	11B-37	23737-00	37-37
23553-04	40-7	23596-00	33-9	23669-03	11B-54	23737-00	37-44
23553-05	40-7	23597-00	13-25	23669-04	11B-53	23738-00	37-34
23554-00	40-14	23597-02	13-27	23669-05	11B-54	23738-01	37-34
23554-02	40-14	23597-03	13-26	23669-06	11B-53	23738-06	37-34
23555-08	36-30	23597-06	13-25	23669-07	11B-55	23738-07	37-34
23555-09	36-30	23598-00	34-23	23669-09	11B-37	23740-02	37-36
23555-10	36-31	23602-00	10-33	23670-00	51-10	23740-03	37-36
23555-11	36-31	23603-00	10-37	23675-04	10-3	23740-08	37-36
23556-02	36-46	23603-04	10-37	23675-05	10-4	23740-09	37-36
23556-03	36-46	23605-00	41-25	23675-09	9-33	23741-00	7-13
23556-04	36-51a	23606-00	41-38	23675-09	9A-10	23743-04	10-20
23556-05	36-51a	23607-00	14-30	23675-10	9-34	23743-05	10-20
23556-06	36-51a	23615-00	10-38	23675-10	9A-12	23744-02	37-43
23556-07	36-51a	23615-01	10-38	23675-11	9-34	23744-03	37-43
23558-00	12-30	23616-00	10-39	23675-11	9A-12	23744-08	37-43
23558-00	23-32	23616-01	10-39	23675-13	10-2	23744-09	37-43
23560-00	2-64	23617-00	10-9	23678-00	41-56	23745-02	19-25
23560-01	2-64	23617-02	10-10	23678-02	41-56	23745-03	38-19
23560-02	6-18	23618-00	10-41	23678-03	41-56	23745-05	35-7
23560-03	6-18	23618-01	10-41	23680-00	8-1	23745-06	35-8
23560-06	2-64	23618-01	10-41	23680-02	8-22	23745-07	38-20
23560-07	2-64	23625-00	11B-46	23680-03	8-23	23745-08	23-6
23561-00	35-6	23626-00	10-12	23680-07	8-22	23746-00	37-38
23561-31	35-6	23626-01	10-12	23680-08	8A-23	23747-00	19-26
23562-00	4-1	23632-00	11B-63	23680-11	8-1	23748-00	13-1
23562-01	4-1	23632-01	11B-63	23682-00	37-13	23749-00	37-14
23562-06	6-3	23633-00	10-40	23682-01	37-13	23752-00	23-7
23562-07	6-3	23635-01	11B-30	23684-00	23-4	23752-01	19-56
23562-08	6-5	23627-00	11B-47	23684-02	23-5	23755-00	7-29
23562-09	6-5	23640-00	47-6	23685-00	36-54	23756-02	8-17
23562-10	6-2	23643-00	10-42	23685-01	36-54	23756-02	8A-17
23562-11	6-2	23643-01	10-42	23690-04	10-19	23757-02	44-2
23564-00	4-43	23644-03	11B-34	23690-05	10-19	23759-00	19-33
23564-01	4-43	23645-00	10-11	23691-05	10-6	23760-00	19-27
23565-00	4-39	23648-00	11B-9	23691-06	10-6	23763-02	13-8
23565-01	4-39	23648-03	11B-12	23694-00	19-21	23763-03	13-8
23568-00	36-32	23648-04	11B-13	23696-00	38-66	23763-04	13-8
23568-01	36-32	23656-02	10-5	23696-03	38-66	23763-11	13-8
23568-04	36-33	23656-03	10-5	23697-02	10-45	23763-12	13-8
23568-05	36-33	23657-00	36-3	23697-03	10-45	23763-13	13-8
23568-08	36-32	23658-00	24-14	23697-04	10-46	23765-00	11B-64
23568-09	36-32	23658-22	24-14	23697-05	10-44	23766-00	19-42
23569-00	15-29	23659-00	40-21	23698-00	7-10	23767-02	13-22
23569-02	15-29	23659-01	40-21	23703-00	8-20	23767-03	13-22
23570-00	36-47	23660-04	10-30	23703-00	8A-21	23767-04	13-22
23570-01	36-47	23660-05	10-31	23703-00	10-1	23767-11	13-22
23572-00	36-48	23660-06	10-7	23703-03	8A-21	23767-12	13-22
23572-01	36-48	23660-07	10-7	23703-03	10-1	23767-13	13-22
23575-00	6-10	23662-00	11-20	23705-00	19-22	23768-05	13-17
23576-00	36-52	23662-00	11A-20	23707-00	11B-32	23771-00	13-10
23576-01	36-52	23663-00	11-21	23709-00	7-11	23771-03	13-11
23577-00	36-53	23663-00	11A-21	23709-01	7-11	23773-00	13-9

# PIPER PARTS CATALOG

Part Number	Fig. and Index	Part Number	Fig. and Index	Part Number	Fig. and Index	Part Number	Fig. and Index
23776-00	8-18	23834-01	7-16	23864-12	15-13	23928-00	38-25
23776-03	8-19	23834-04	7-16	23864-13	15-13	23929-00	38-26
23776-03	8A-20	23835-00	7-21	23864-14	15A-49	23929-00	40A-14
23776-04	8A-19	23835-01	7-21	23864-15	15A-49	23930-00	38-27
23787-00	28-1	23836-00	7-22	23864-16	15A-49	23931-00	38-28
23788-00	7-14	23837-00	7-1	23864-17	15A-49	23933-00	38-29
23789-00	35-45	23837-00	8-31	23864-22	15A-49	23934-00	38-30
23795-00	36-55	23837-02	7-2	23866-00	35-49	23935-00	38-31
23799-00	39-19	23837-03	7-3	23866-04	35-49	23936-00	38-32
23799-01	39-19	23837-06	7-6	23867-04	36-15	23937-00	38-33
23803-00	4-41	23837-07	7-7	23868-00	44-14	23938-00	38-34
23803-01	4-41	23837-08	7-5	23871-00	44-8	23939-00	38-35
23805-00	10-53	23837-13	7-26	23872-00	19-37	23943-00	42A-24
23807-00	35-46	23837-15	7-23	23872-02	19-37	23943-00	42B-18
23807-12	35-46	23837-28	7-4	23874-00	7-17	23946-00	28-12
23809-04	35-9b	23837-33	7-4	23874-01	7-17	23946-01	28-12
23809-10	35-9a	23837-37	7-1	23875-00	7-18	23950-00	28-3
23810-00	35-9	23837-37	8-31	23875-01	7-18	23950-01	28-3
23811-00	37-15	23837-38	7-26	23877-00	7-19	23951-00	47-7
23815-00	35-10	23837-39	7-1	23877-01	7-19	23953-00	47-9
23818-00	35-11	23837-39	8A-34	23878-00	7-20	23954-00	48-29
23819-00	35-12	23837-40	7-4	23878-01	7-20	23956-00	24-55
23819-03	35-12	23838-00	22-4	23880-00	28-11	23957-00	47-23
23820-00	8-7	23838-01	22-4	23882-00	19-50	23959-00	36-5
23820-04	8-8	23839-02	10-21	23883-00	35-14	23959-01	36-5
23820-04	8A-11	23839-04	10-21	23883-05	35-14	23964-02	38-36
23820-05	8-8	23841-00	22-5	23884-02	23-8	23964-03	38-37
23820-05	8A-11	23841-01	22-5	23884-03	23-8	23968-00	14-33
23820-06	8-9	23842-00	36-2	23885-00	17-1	23969-02	41-21
23820-06	8A-18	23844-00	41-39	23886-00	35-15	23969-02	41-96
23820-07	8-9	23844-00	41-45	23887-02	23-9	23969-02	42-4
23820-07	8A-18	23844-00	42B-22	23887-03	23-9	23969-02	42D-9
23820-08	10-26	23845-00	35-62	23888-00	23-10	23969-03	41-63
23820-09	10-26	23849-00	35-47	23889-00	23-11	23969-04	41-22
23820-10	10-27	23849-04	35-47	23892-00	23-12	23969-04	41-97
23820-11	10-27	23850-08	35-27	23892-03	23-12	23969-04	42-5
23820-12	10-28	23850-10	35-28	23893-00	23-13	23969-04	42C-16
23820-13	10-28	23850-11	35-29	23893-03	23-13	23969-04	42D-10
23820-14	8-10	23850-12	35-30	23894-00	23-14	23970-00	29-10
23820-15	8A-14	23850-14	35-30	23895-00	23-15	23972-00	10-48
23820-16	8-17a	23854-00	35-51	23896-00	23-16	23973-00	29-11
23820-16	8A-18a	23855-00	36-4	23900-00	17A-3	23974-00	28-13
23820-17	8-7	23855-01	36-4	23905-00	11B-14	23975-00	28-14
23821-02	13-23	23855-04	36-4	23906-00	36-35	23977-09	35-52
23821-03	13-23	23855-05	36-4	23907-00	35-50	23978-00	11B-42
23821-04	13-23	23857-00	14A-16	23907-07	35-50	23982-00	29-5
23821-11	13-23	23857-00	42A-8	23908-00	11B-50	23982-02	29-6
23821-12	13-23	23857-00	42B-9	23909-00	11B-51	23983-00	36-29a
23821-13	13-23	23860-00	35-47	23910-00	47-28	23986-00	35-17
23824-00	11B-49	23862-00	36-14	23919-00	29-3	23986-04	35-17
23825-00	11B-49	23862-01	36-14	23922-00	15-8	23990-00	2-50
23827-39	8A-17	23862-05	36-14	23923-00	47-45	23990-01	2-50
23828-00	10-49	23862-06	36-14	23924-00	38-21	23991-00	2-51
23830-02	37-16	23864-02	15-13	23924-01	38-21	23991-01	2-51
23830-03	37-17	23864-03	15-13	23925-00	38-22	23995-00	35-9c
23832-00	37-18	23864-04	15-13	23925-00	40A-14	24010-00	37-19
23833-00	7-15	23864-11	15-13	23926-00	38-23	24012-00	36-50
23834-00	7-16	23864-11	15A-49	23927-00	38-24	24012-01	36-50

# PIPER PARTS CATALOG

Part Number	Fig. and Index	Part Number	Fig. and Index	Part Number	Fig. and Index	Part Number	Fig. and Index
24013-00	36-49	24075-02	15-14	24128-03	38-44	24217-03	Misc.
24014-00	37-20	24075-03	15-14	24128-06	38-44	24217-04	14-66
24015-00	23-26	24075-04	15-14	24128-14	38-44	24217-04	Misc.
24016-00	37-21	24075-23	15-14	24128-15	38-44	24218-00	16-23
24016-02	37-22	24075-23	15A-46	24128-16	38-44	24220-00	21-9
24018-00	45-19	24075-24	15-14	24130-00	37-48	24221-00	30-10
24019-00	16-35	24075-25	15-14	24130-01	37-48	24222-00	21-10
24019-00	16A-31	24075-26	15A-46	24133-00	37-49	24226-00	44-4
24020-00	16-34	24075-27	15A-46	24134-00	37-49	24227-03	54-13
24020-00	16A-14	24075-28	15A-46	24135-00	37-28	24232-00	51-6
24022-00	29-23	24075-29	15A-46	24136-00	37-51	24233-00	49-9
24023-00	48-44	24075-42	15A-46	24136-01	37-51	24233-00	51-17
24023-02	48-44	24077-00	36-20	24139-00	37-52	24238-00	51-11
24024-00	48-43	24078-03	41-40	24139-01	37-50	24239-00	51-5
24024-02	48-43	24080-00	11B-31	24140-00	41-35	24241-00	51-12
24025-00	48-42	24081-00	37-25	24143-00	13-21	24242-00	21-19
24025-02	48-42	24082-00	37-26	24143-02	13-21	24245-00	18-44
24026-00	48-40	24087-00	47-34	24147-00	38-49	24246-00	18-46
24027-00	48-41	24088-00	38-50	24148-00	38-45	24247-02	18-37
24029-00	36-25	24089-00	38-46	24149-00	38-53	24247-03	18-37
24029-11	36-26	24091-00	38-51	24150-00	38-40	24247-04	18-37
24029-12	36-26	24091-02	17A-41	24150-00	38-43	24252-00	19-49
24031-00	17A-4	24092-00	38-48	24151-00	19-52	24255-00	19-48
24033-00	28-15	24092-00	38-52	24153-00	37-85	24259-00	12-20
24033-01	28-15	24093-00	38-39	24154-00	37-53	24268-00	38-110
24037-00	38-79	24094-00	38-42	24154-00	41-115	24272-00	21-11
24039-00	35-18	24100-00	38-38	24155-00	37-54	24273-00	21-12
24041-00	40-19	24102-00	38-41	24161-00	37-57	24284-00	21-13
24041-01	40-19	24103-00	13-3	24164-00	17-57	24285-00	21-14
24041-04	40-19	24103-01	13-4	24167-02	36-18	24288-00	8-2
24041-05	40-19	24104-00	13-5	24169-00	6-31	24288-00	12-1
24042-00	16-36	24104-04	13-5	24170-00	37-86	24288-03	12-26
24042-00	16A-30	24106-00	13-6	24172-00	37-87	24290-00	21-18a
24047-00	37-39	24107-00	36-21	24173-00	15-22	24292-00	12-16
24048-00	37-40	24108-02	36-13	24173-00	15A-8	24298-02	21-15
24049-00	37-41	24108-03	36-19	24173-02	15A-60	24298-03	21-15
24051-02	38-80	24108-04	36-19	24174-00	38-54	24302-00	47-36
24051-03	38-81	24108-11	36-1	24177-00	9-38	24304-00	47-37
24051-04	38-82	24108-12	36-1	24177-02	9A-34	24307-00	21-16
24051-05	38-83	24108-13	36-9	24179-00	31-43	24307-02	21-16
24052-00	28-16	24108-14	36-9	24191-00	32-33	24308-00	21-17
24053-00	38-84	24114-00	36-6	24192-00	32-34	24308-02	21-17
24053-02	38-84	24116-00	13-24	24193-00	32-31	24309-00	47-18
24054-00	11B-33	24117-00	17-8	24193-02	32-32	24309-00	47-49
24055-02	36-27b	24118-00	36-11	24196-00	21-33	24310-00	11B-67
24055-03	36-27b	24119-00	36-12	24197-02	49-14	24314-00	11B-65
24055-04	36-27	24120-02	37-45	24197-04	49-14	24315-00	11B-66
24057-02	36-27c	24120-04	37-45	24206-00	14-31	24316-00	12-64
24057-03	36-27c	24122-00	37-42	24206-02	14-31	24317-00	12-65
24057-04	36-27a	24122-01	37-42	24208-00	36-51	24318-00	11B-23
24059-00	38-85	24122-02	37-42	24211-00	14-62	24319-00	47-12
24060-00	38-86	24122-03	37-42	24212-00	14-67	24320-00	47-60
24064-00	47-29	24123-00	37-27	24212-03	14-67	24321-00	47-38
24067-00	47-30	24124-00	37-56	24216-00	14-61	24322-00	47-19
24068-00	47-31	24125-00	47-24	24216-00	Misc.	24322-00	47-50
24069-00	47-32	24126-00	36-8	24217-00	14-66	24323-00	21-18
24070-00	47-33	24126-01	36-8	24217-00	Misc.	24325-00	47-20
24074-00	37-24	24128-02	38-44	24217-03	14-66	24325-00	47-51

# PIPER PARTS CATALOG

Part Number	Fig. and Index	Part Number	Fig. and Index	Part Number	Fig. and Index	Part Number	Fig. and Index
24326-00	12-63	24617-07	18-19a	24819-01	25-66	24967-18	15-62
24327-00	12-84	24617-08	18-19a	24822-02	15B-1	24967-19	15-62
24328-00	12-85	24617-09	18-19a	24822-03	15B-2	24991-00	49-15
24329-00	45-47	24623-00	23B-63	24827-00	18-47	24992-03	14-67
24330-00	47-40	24623-00	23C-61	24849-00	15-59	24995-00	38-75
24334-00	33-25	24624-00	42-53	24849-00	15A-36	24999-00	14-58
24336-00	10-47	24624-00	51-56	24870-00	2-60	24999-03	14-58
24337-00	47-41	24624-00	52-6	24870-01	2-60	24999-05	14-58
24338-00	47-42	24629-00	45-50	24893-03	15-26	25004-03	14-31
24340-00	47-43	24631-04	45-51	24893-04	15-26	25008-00	49-28
24341-00	47-46	24631-06	45-51	24894-03	37-88	25008-00	51-60
24342-00	47-27	24641-00	41-77	24894-03	37-89	25011-00	18-20
24345-02	47-21	24641-00	51-57b	24894-03	37-90	25011-02	18-20
24345-03	47-52	24641-00	52-38	24912-00	25-56a	25011-03	18-20
24346-00	47-16	24641-00	52-41	24912-01	25-56a	25011-04	18-20
24357-00	37-47a	24641-00	52-73	24915-00	25-62a	25011-05	18-20
24358-00	37-47	24671-00	19-57	24916-00	24-36	25011-06	18-20
24362-00	37-21	24672-00	19-26	24918-00	25-79	25011-07	18-20
24362-02	37-22	24673-00	19-49	24932-00	46-14	25011-08	18-20
24371-00	36-56	24677-00	26-27b	24933-00	46-14a	25012-00	18-21
24382-00	38-76	24678-00	26-27a	24934-00	14-31b	25012-02	18-21
24385-00	30A-5	24679-00	26-27	24934-00	14-69	25012-03	18-21
24392-00	30A-6	24679-01	26-27	24935-00	15-63	25012-04	18-21
24393-00	30A-7	24680-00	26-20	24935-00	15A-37	25012-05	18-21
24394-00	30A-8	24680-01	26-20	24936-00	14-31c	25012-06	18-21
24408-00	30A-11	24681-05	25-71	24936-00	14-70	25012-07	18-21
24409-00	30A-11	24681-05	26-1	24939-00	14-31d	25012-08	18-21
24424-00	40-36	24682-00	55-3	24939-00	14-71	25021-00	14-65a
24426-00	30A-9	24704-00	42-50	24940-00	14-31e	25037-00	51-55
24427-00	30A-10	24705-00	15-5	24940-00	14-72	25046-00	25-62
24428-00	30A-13	24705-05	15A-13	24941-00	14-77	25047-00	22-34
24428-02	30A-13	24712-00	14-80	24945-00	15-5a	25048-02	48-36
24451-00	21-19	24712-02	14-80	24948-00	29-32	25060-00	32-22
24452-00	19-33	24712-02	14A-47	24948-00	46-10	25065-02	32-21
24456-00	19-27	24712-02	50-6	24949-00	19-33a	25065-03	32-25
24492-00	37-63	24712-02	50-7	24950-00	19-33b	25066-00	32-2
24493-00	37-62	24712-02	52-11	24951-00	19-33c	25067-02	32-20
24495-00	37-64	24712-02	52A-36	24953-00	15-61	25067-03	32-19
24495-02	37-64	24726-00	19-48	24953-01	15-61	25067-04	32-18
24532-04	36-15	24727-00	19-33	24953-02	15-61	25067-05	32-17
24533-02	36-13	24729-00	19-52	24953-05	15-61	25077-02	32-29
24533-03	36-19	24730-00	19-27	24953-08	15-61	25077-03	32-28
24533-04	36-19	24737-00	21-18a	24953-09	15-61	25077-04	32-27
24533-05	36-1	24750-00	25-34	24954-00	47-28a	25077-05	32-26
24533-06	36-1	24773-00	25-76	24955-00	47-28b	25078-00	32-30
24533-07	36-9	24775-00	26-46	24958-00	38-44a	25079-00	37-81
24533-08	36-9	24794-00	7-32	24959-00	38-44b	25082-00	32-5
24536-00	14-32	24796-00	7-33	24960-00	14-31f	25083-02	32-7
24550-02	15B-6	24797-00	7-34	24960-00	14-73	25083-03	32-7
24550-03	15B-5	24799-02	51-62	24960-00	38-44c	25094-00	32-16
24550-04	15B-4	24799-03	51-63	24961-00	47-28c	25095-00	19-58
24550-05	15B-3	24801-00	51-64	24962-00	47-28d	25097-00	31-4
24577-00	35-3	24802-00	51-65	24963-00	47-28e	25098-00	31-2
24617-02	18-19a	24805-00	51-54	24964-00	38-44d	25098-01	31-2
24617-03	18-19a	24812-00	13-32	24967-00	15-62	25099-00	32-23
24617-04	18-19a	24813-00	48-35	24967-01	15-62	25100-00	31-1
24617-05	18-19a	24817-00	13-30	24967-05	15-62	25100-00	32-1
24617-06	18-19a	24819-00	25-66	24967-08	15-62	25100-01	31-1



## PIPER PARTS CATALOG

Part Number	Fig. and Index	Part Number	Fig. and Index	Part Number	Fig. and Index	Part Number	Fig. and Index
25100-01	32-1	25243-04	11A-61	25306-09	11A-62	25355-04	9A-38
25100-02	32-11	25244-00	11A-61	25308-00	12-81	25355-06	8A-6
25100-03	32-12	25245-00	36-19	25310-00	12-69	25355-07	9A-37
25100-04	32-9	25245-01	36-19	25313-00	11A-40	25355-08	8A-3
25100-05	32-9	25246-00	35-9d	25313-01	11A-40	25357-00	11A-52
25100-06	32-10	25247-00	36-25	25314-03	9A-27	25365-00	15A-2
25100-07	32-10	25247-04	36-26	25315-00	11A-44a	25366-00	12-82
25101-00	32-33	25247-05	36-26	25315-04	11A-44a	25369-00	37-19
25102-00	32-34	25247-06	36-25	25316-00	11A-39	25373-02	13-34
25103-02	32-31	25247-08	36-26	25316-01	11A-39	25373-03	13-35
25103-03	32-32	25249-00	36-41	25318-02	11A-24	25374-02	11A-59
25105-00	32-15	25249-01	36-41	25318-03	11A-24	25375-00	11A-60
25105-01	32-15	25250-02	36-13	25318-04	11A-25	25378-00	13-36
25106-00	32-37	25250-03	36-1	25318-05	11A-25	25379-00	13-15a
25106-01	32-37	25250-04	36-1	25319-00	11A-45	25379-00	13-16a
25107-02	32-36	25251-00	36-14	25320-02	11A-8	25380-00	13-15b
25107-03	32-35	25253-00	36-14	25320-03	11A-8	25380-00	13-16b
25110-00	32-13	25255-00	11B-68	25320-04	11A-7	25382-02	8A-16
25111-00	32-14	25256-00	11B-9	25320-05	11A-26	25382-07	8A-16
25130-00	49-29	25265-00	38-111	25320-06	11A-9	25383-00	8A-8
25130-00	51-66	25274-00	11A-42	25320-08	11A-7	25383-02	8A-13
25137-00	29-7	25274-01	11A-42	25320-09	11A-7	25383-05	8A-15
25139-03	33-10	25276-00	14-81	25320-10	11A-8	25383-06	8A-9
25156-02	15-57	25277-00	14-83	25321-00	9A-42	25383-07	8A-9
25156-04	15-58	25278-00	14-82	25321-01	9A-42	25383-12	10-22
25156-06	15A-40	25278-00	Misc	25323-02	9A-26	25383-12	11A-57
25156-18	15A-39	25279-00	38-59	25323-03	9A-26	25383-13	10-22
25156-20	15A-39	25279-02	38-59	25328-00	11A-49	25383-13	11A-53
25156-22	15A-40	25281-00	15A-4	25328-01	11A-49	25384-00	8A-2
25156-24	15A-40	25281-00	17-55	25330-00	16A-47	25384-00	12-1
25156-26	15A-40	25281-02	15A-4	25332-00	9A-43	25384-02	12-5
25156-28	15A-40	25281-02	17-55	25332-01	9A-43	25384-04	8A-2
25156-30	15A-40	25281-03	15A-4	25333-00	8A-22	25384-04	12-1
25162-00	10-57	25281-03	17-55	25333-00	11A-1	25389-00	17A-40
25162-01	10-57	25283-00	15A-3	25333-02	11A-31	25392-02	23A-2
25163-05	17-37	25283-00	17-56	25333-03	11A-31	25392-02	23B-2
25163-05	17A-6	25285-00	18A-23	25333-04	11A-29	25392-02	23C-2
25203-00	41-52	25285-00	18A-39	25333-05	11A-29	25392-03	23A-3
25219-00	15-25	25286-00	11A-6	25333-12	11A-32	25392-03	23B-3
25220-00	23-36	25286-01	11A-6	25333-17	8A-22	25392-03	23C-3
25223-02	18A-11	25290-09	23-49	25333-17	11A-1	25392-04	23A-4
25223-03	18A-11	25292-02	11A-41	25334-00	9A-8	25392-04	23B-4
25223-04	18A-11	25292-03	11A-41	25334-01	9A-8	25392-04	23C-4
25223-12	18A-11	25292-04	11A-63	25336-00	40A-36	25393-00	23A-5
25223-15	18A-11	25292-05	11A-63	25341-04	9A-29	25393-00	23B-5
25223-18	18A-11	25299-00	11A-54	25341-04	11A-65	25394-00	23A-6
25223-21	18A-11	25299-01	11A-54	25341-05	9A-29	25394-00	23B-6
25223-24	18A-11	25300-02	11A-56	25341-05	11A-65	25394-00	23C-6
25223-25	18A-11	25300-03	11A-56	25343-00	12-86	25395-00	23A-7
25223-48	18A-11	25300-06	11A-57	25343-01	12-86	25395-00	23B-7
25231-00	36-5	25304-04	12-36	25344-00	9A-24	25395-00	23C-7
25231-01	36-5	25304-05	12-36	25353-00	11A-66	25396-00	23A-8
25232-00	36-4	25306-02	11A-43	25353-01	11A-66	25396-00	23B-8
25232-01	36-4	25306-03	11A-43	25354-00	11A-50	25396-00	23C-8
25239-00	41-74	25306-04	9A-25	25354-01	11A-50	25397-00	23A-9
25242-02	18A-21	25306-05	9A-25	25355-00	8A-3	25397-00	23B-9
25243-02	11A-61	25306-07	9A-13	25355-00	9A-1	25397-00	23C-9
25243-03	11A-61	25306-08	11A-62	25355-03	8A-5	25398-00	12-83

# PIPER PARTS CATALOG

Part Number	Fig. and Index
25398-01	12-83
25403-00	13-33
25410-00	5-2
25410-01	5-2
25412-02	15B-4
25412-03	15B-6
25412-04	15B-3
25412-05	15B-5
25414-02	16A-26
25414-03	16A-26
25414-04	16A-27
25414-05	16A-27
25415-02	16A-28
25415-03	16A-28
25415-04	16A-29
25415-05	16A-29
25416-00	16A-21
25417-00	16A-22
25418-00	16A-23
25419-00	15A-1
25421-00	51-69
25422-00	51-70
25425-00	17A-11
25427-04	15A-30
25427-16	15A-29
25428-00	17A-12
25429-00	17A-13
25432-00	17A-14
25437-00	17A-15
25438-00	17A-16
25444-00	17A-17
25447-00	17A-18
25449-00	25-30
25453-00	18A-45
25454-00	18A-44
25456-00	17A-20
25457-00	17A-21
25459-00	17A-42
25460-00	17A-22
25461-02	8A-7
25461-03	8A-25
25461-04	8A-24
25461-05	8A-24
25461-06	8A-26
25463-00	16A-43
25464-00	17A-23
25467-00	18A-7
25472-00	15A-42
25473-00	17A-24
25475-00	15A-14
25476-12	15A-16
25477-03	15A-23
25478-02	15A-47
25478-06	15A-47
25478-10	15A-47
25478-14	15A-47
25478-22	15A-47
25478-37	15A-47

Part Number	Fig. and Index
25478-38	15A-47
25478-39	15A-47
25478-40	15A-47
25478-41	15A-47
25478-47	15A-47
25479-02	15A-48
25479-04	15A-48
25479-06	15A-48
25479-08	15A-48
25479-10	15A-48
25479-17	15A-48
25481-02	15A-50
25481-03	17-46
25481-04	15A-50
25481-05	17-46
25481-06	15A-50
25481-07	17-46
25481-08	15A-50
25481-09	17-46
25481-19	17-46
25481-20	15A-50
25481-23	17-46
25481-24	15A-50
25481-27	17-46
25481-28	15A-50
25481-31	17-46
25481-32	15A-50
25481-35	17-46
25481-36	15A-50
25481-39	17-46
25481-40	15A-50
25482-02	18A-43
25482-03	18A-43
25482-04	18A-43
25482-05	18A-43
25482-10	18A-43
25482-12	18A-43
25482-14	18A-43
25482-16	18A-43
25482-18	18A-43
25482-20	18A-43
25489-00	17A-9
25490-00	7-27
25491-02	13-8
25491-04	13-8
25491-06	13-8
25491-08	13-8
25491-10	13-23
25491-12	13-23
25491-14	13-23
25491-16	13-23
25491-18	13-8
25491-20	13-23
25491-32	13-23
25493-02	13-22
25493-04	13-22
25493-06	13-22
25493-08	13-22

Part Number	Fig. and Index
25493-10	13-22
25493-10	13-22
25494-00	8A-1
25496-02	16A-12
25496-03	16A-12
25496-04	16A-15
25497-02	16A-13
25497-03	16A-13
25497-04	16A-16
25498-02	15A-24
25502-00	7-28
25503-10	18A-37
25506-00	17A-2
25508-00	17A-3
25509-02	17A-1
25510-00	17-34
25514-00	7-28
25515-02	18A-12
25515-03	18A-12
25515-04	18A-12
25515-05	18A-12
25515-08	18A-14
25515-09	18A-14
25515-10	18A-14
25515-11	18A-14
25515-14	18A-13
25515-15	18A-13
25519-02	18A-26
25519-03	18A-26
25519-04	18A-26
25519-05	18A-26
25519-14	18A-26
25519-15	18A-26
25519-18	18A-26
25519-19	18A-26
25521-00	15A-22
25524-00	17-1
25533-00	15A-20
25533-00	15A-26
25534-02	18A-47
25534-03	18A-47
25534-18	18A-47
25535-02	18A-46
25535-03	18A-46
25535-23	18A-46
25541-00	17A-4
25543-00	13-15
25544-02	13-16
25547-00	14-62
25547-02	14-30
25550-02	18A-28
25550-03	18A-28
25550-04	18A-28
25550-05	18A-28
25550-08	18A-30
25550-09	18A-30
25550-10	18A-30
25550-11	18A-30

Part Number	Fig. and Index
25550-14	18A-29
25550-15	18A-29
25550-16	18A-29
25550-17	18A-29
25552-00	18A-8
25552-03	18A-49
25554-00	12-87
25557-02	14-31
25557-03	14-67
25564-00	12-87
25566-00	14-61
25566-00	Misc.
25567-00	15A-44
25568-02	23B-31
25568-03	23B-32
25568-04	23B-33
25568-05	23B-34
25568-06	23B-35
25568-08	23B-29
25568-08	23C-29
25568-10	23B-67
25568-11	23B-68
25568-12	23B-69
25568-12	23C-32
25568-13	23B-70
25568-14	23B-66
25568-15	23C-33
25568-16	23C-34
25568-17	23C-35
25568-18	23C-30
25568-19	23C-37
25568-20	23C-38
25568-21	23C-36
25571-00	21-18a
25572-00	21-18c
25573-00	21-18
25574-00	21-16
25575-00	14-66
25575-00	Misc.
25575-02	14-66
25575-02	Misc.
25577-02	14-31
25577-03	14-67
25578-00	11A-51
25580-00	21-17
25590-00	17-54
25590-00	17A-7
25595-00	17A-39
25595-00	17A-43
25596-00	41-78
25596-00	51-61
25596-00	52-22
25597-00	2-65
25598-00	18A-4
25598-02	18A-4
25598-03	18A-4
25598-04	18A-4
25598-05	18A-4

# PIPER PARTS CATALOG

Part Number	Fig. and Index	Part Number	Fig. and Index	Part Number	Fig. and Index	Part Number	Fig. and Index
25598-06	18A-4	25712-00	23-16	25862-00	41-62	26248-02	39-7
25598-07	18A-4	25713-00	14-58	25867-02	6-20	26248-07	39-7
25598-08	18A-4	25715-00	52-4	25867-03	6-20	26249-02	39-1
25598-17	18A-4	25716-00	50-11	25867-04	6-21	26249-08	39-1
25598-18	18A-4	25716-00	52-24	25867-05	6-21	26250-00	11B-30
25598-21	18A-4	25719-00	29-23	25867-06	6-19	26272-00	14-99
25598-22	18A-4	25720-00	29-18	25867-07	6-19	26273-00	14-100
25598-25	18A-4	25720-02	29-20	25871-00	52-68	26319-00	15A-2
25598-26	18A-4	25720-03	29-19	25876-00	10-15c	26320-00	14-58
25599-00	52-5	25720-04	46-17	25876-01	10-15c	26330-00	15A-12
25599-00	52A-47	25740-00	13-42	25880-00	8A-36	26339-00	8A-19
25603-00	23A-41	25741-00	13-43	25900-04	40-23	26343-00	2-5
25603-00	23B-10	25742-00	13-41	25900-05	40-23	26343-00	46-80
25603-00	23C-10	25743-00	50-10	25951-00	23B-25	26347-00	Misc.
25604-00	13-39	25743-00	52-23	25951-00	23C-25	26355-00	10-12
25605-00	13-37	25758-04	41-23	25956-00	35-15	26355-01	10-12
25606-00	Misc.	25780-02	45-48	25960-02	50-8	26356-00	42B-46
25620-00	38-11	25780-03	45-49	25960-02	52-28	26358-00	8A-19
25621-00	7-10	25781-00	17A-36	25960-02	52A-33	26358-03	8A-20
25623-00	11B-41	25782-00	17A-10	25960-03	52-29	26358-04	8A-19
25624-00	11B-46	25783-00	14-62	25960-03	52A-34	26358-05	8A-19
25632-00	42D-8	25783-02	14-30	25973-00	35-19	26360-02	8A-16
25654-02	39-11	25784-00	14-61	25975-02	31-23	26360-03	8A-16
25654-06	40-27a	25784-00	Misc.	25975-03	31-23	26361-00	8A-8
25655-00	39-8	25785-02	14-31	25977-03	10-4	26361-06	8A-8
25656-02	39-7	25785-03	14-67	26049-02	45-1	26361-07	8A-8
25656-09	39-7	25786-00	14-66	26088-02	56-1	26362-04	14A-28
25657-00	11A-68	25786-00	Misc.	26088-03	56-1	26362-08	14A-28
25666-00	26-56	25786-02	14-66	26088-04	56-1	26362-09	14A-28
25670-00	11B-72	25786-02	Misc.	26088-05	56-1	26362-10	14A-28
25671-00	52-8	25788-03	12-88	26088-06	56-1	26368-00	47-61
25672-00	11B-9	25793-02	14-94	26088-07	56-1	26369-00	42B-6
25673-00	50-1	25794-00	11B-9	26088-08	56-1	26371-00	47-34
25675-00	10-52	25796-02	14-31	26088-09	56-1	26372-00	15A-10
25677-00	52-7	25796-03	14-67	26088-10	56-1	26372-01	15A-10
25680-00	36-12a	25801-02	18A-1	26088-11	56-1	26374-00	15A-18
25684-00	14-95	25801-03	18A-1	26088-12	56-1	26374-01	15A-25
25689-02	52A-27	25801-04	18A-1	26088-13	56-1	26375-00	19-50
25691-00	36-18a	25801-05	18A-2	26088-14	56-1	26377-00	37-51
25692-00	13-40	25801-06	18A-2	26088-15	56-1	26380-00	37-52
25694-00	15A-68	25801-07	18A-2	26099-00	9A-43	26380-02	37-50
25696-02	15A-69	25801-08	18A-2a	26100-00	50-24	26383-00	11B-59
25696-03	15A-70	25801-10	18A-2a	26100-00	52-66	26387-00	11B-58
25697-00	23B-5	25801-11	18A-2a	26100-00	52A-59	26388-00	11B-22
25697-00	23C-5	25821-00	9A-39	26103-00	11A-27a	26398-02	14A-1
25698-00	15A-36	25829-01	9A-43	26119-00	13-35	26398-03	14A-1
25700-02	14-2	25832-00	9A-8	26130-04	13-44	26398-04	14A-1
25700-02	14A-15	25832-01	9A-8	26130-05	13-44	26398-05	14A-1
25701-00	14-96	25839-00	41-75	26130-06	13-44	26398-06	14A-1
25702-00	14-98	25842-00	9A-4	26130-07	13-44	26398-12	14A-1
25704-00	5-31	25843-02	9A-28	26130-08	13-44	26398-13	14A-1
25704-00	5-35	25843-02	11A-64	26130-09	13-44	26398-14	14A-1
25705-00	23-46	25843-03	9A-28	26147-00	13-36	26398-15	14A-1
25705-00	52-63	25843-03	11A-64	26156-00	56-9	26398-16	14A-1
25705-00	52-86	25846-00	52-69	26161-00	11B-70	26398-17	14A-1
25705-00	52A-39	25854-00	41-109	26189-13	15A-31	26398-18	14A-1
25706-00	52-20	25854-02	41-109	26189-14	15A-29	26398-19	14A-1
25707-00	52-21	25855-02	41-107	26246-00	39-9	26398-20	14A-1

## PIPER PARTS CATALOG

Part Number	Fig. and Index	Part Number	Fig. and Index	Part Number	Fig. and Index	Part Number	Fig. and Index
26398-21	14A-1	26523-04	14A-4	26609-02	18A-30	26692-10	14A-6
26416-00	37-65	26523-05	14A-4	26609-03	18A-30	26692-12	14A-6
26418-00	14A-32	26523-06	14A-4	26609-04	18A-30	26692-13	14A-6
26418-02	14A-32	26524-02	23C-65	26609-05	18A-30	26692-14	14A-6
26419-02	47-28	26524-03	23C-65	26610-02	42B-21	26692-15	14A-6
26419-03	47-28	26524-04	23C-65	26613-00	21-16	26692-16	14A-6
26419-04	47-28	26529-00	29-49	26613-02	21-16	26694-00	15A-23
26421-00	37-56	26534-00	14A-34	26614-00	11A-6	26695-00	41-44
26422-00	14A-32	26535-02	23C-66	26616-00	15A-53	26696-00	15A-16
26423-00	14A-32	26535-03	23C-66	26617-00	18A-12	26710-06	16A-21
26424-00	37-48	26535-04	23C-66	26617-01	18A-12	26710-07	16A-21
26425-00	37-48	26538-05	18A-29	26617-02	18A-12	26718-02	16A-22
26426-00	14A-33	26538-06	18A-29	26617-03	18A-12	26718-03	16A-22
26427-00	11B-15	26538-07	18A-29	26617-04	18B-1	26724-00	17A-1
26428-02	14A-2	26538-08	18A-29	26617-05	18B-1	26739-00	47-33
26428-03	14A-2	26538-21	18A-13	26617-06	18B-1	26741-00	47-24
26428-04	14A-2	26538-21	18B-2	26617-07	18B-1	26744-00	19-27
26432-00	21-18a	26538-22	18A-13	26618-00	18A-28	26749-05	22-18
26442-00	11B-12	26538-22	18B-2	26618-01	18A-28	26753-00	14A-42
26444-00	11B-13	26541-00	15A-14	26618-02	18A-28	26756-02	15A-38
26444-03	11B-13	26542-00	29-46	26618-03	18A-28	26756-03	15A-38
26445-00	11B-16	26543-00	14A-35	26620-00	42B-35	26758-00	17A-3
26445-00	11B-16a	26549-00	14A-92	26622-00	10-52	26760-00	39-26
26448-00	21-18	26554-02	37-93	26629-00	15A-57	26760-00	40-35
26450-00	8A-1	26554-03	37-93	26629-04	15a-57	26760-01	39-26
26450-02	8A-1	26554-04	37-93	26630-00	21-17	26760-01	40-35
26450-03	8A-1	26555-00	15A-58	26630-02	21-17	26761-00	50-1
26451-00	37-54	26563-04	14A-7	26636-00	42B-10	26762-00	50-27
26452-00	37-54	26563-05	14A-5	26637-02	15A-13	26768-00	15A-51
26453-05	18A-21	26563-10	14A-7	26637-03	15A-13	26771-00	15A-1
26453-05	18A-37	26563-11	14A-5	26637-04	15A-13	26773-02	15A-56
26453-05	18B-8	26563-16	14A-7	26637-05	15A-13	26773-03	15A-52
26456-00	37-54	26563-17	14A-5	26645-00	11A-68	26774-00	42B-17
26458-02	37-49	26563-22	14A-7	26646-00	11A-68	26779-00	14A-30
26458-03	37-49	26563-23	14A-5	26647-00	52-6	26781-00	17-10
26458-04	37-49	26563-28	14A-7	26647-00	52A-48	26787-00	23-16
26467-00	11B-21	26563-29	14A-5	26648-00	52-7	26789-00	50-28
26469-02	14A-29	26564-00	52-63	26649-00	52-4	26794-00	11B-62
26469-03	14A-29	26565-02	15A-55	26653-00	18B-16	26805-06	39-1
26481-00	37-28	26565-03	15A-55	26655-00	41-46	26807-00	24-28
26482-00	11B-37	26565-04	15A-55	26656-00	15A-20	26810-00	11B-21
26482-04	11B-37	26569-00	21-16a	26656-00	15A-26	26813-00	11B-22
26488-00	11B-9	26569-00	21-17a	26657-00	13-24	26813-03	11B-22
26494-02	11B-17	26569-00	21-18d	26659-00	15A-12	26816-00	52-68
26494-03	11B-18	26570-00	19-65	26665-02	43-1	26816-00	52A-46
26496-03	11B-9	26574-02	18A-14	26668-02	16A-23	26820-04	14A-5
26498-00	8A-20a	26574-03	18A-14	26668-03	16A-23	26820-05	14A-7
26499-00	13-21	26574-04	18A-14	26675-00	15A-24	26820-08	14A-5
26509-03	10-55	26574-05	18A-14	26676-04	15A-2	26820-09	14A-7
26511-02	14A-3	26577-00	14A-91	26676-05	15A-2	26820-12	14A-5
26511-03	14A-3	26578-00	10-56	26677-02	17-5	26820-13	14A-7
26511-04	14A-3	26579-00	35-47	26677-03	17-5	26820-16	14A-5
26513-02	10-54	26584-02	18A-46	26679-00	17-34	26820-17	14A-7
26514-00	10-43	26584-03	18A-46	26687-00	17-1	26820-20	14A-5
26517-00	19-69	26591-02	18A-47	26692-02	14A-6	26820-21	14A-7
26522-00	29-45	26591-03	18A-47	26692-04	14A-6	26821-00	14A-26
26523-02	14A-4	26604-00	23-36	26692-06	14A-6	26838-00	52-88
26523-03	14A-4	26604-00	23-36	26692-08	14A-6	26860-00	10-24

# PIPER PARTS CATALOG

Part Number	Fig. and Index
26860-01	10-24
26870-00	14A-65
26878-00	15A-45
26882-00	52-53
26882-02	52A-8
26886-00	15A-36
26890-00	35-60
26893-00	41-46
26895-00	41-44
26934-00	41-110
26934-00	52-82
26934-00	52A-52
26952-00	18B-18
26953-00	18B-20
26961-00	18B-21
26965-00	18B-19
26967-00	41-49
26968-00	41-50
26970-02	18B-3
26970-03	18B-3
26970-04	18B-3
26970-05	18B-3
26996-00	21-32
27001-00	9A-32
27002-00	9A-30
27002-01	9A-30
27003-00	9A-31
27003-01	9A-31
27004-00	Misc.
27005-00	9A-33
27005-01	9A-33
27018-00	18B-15
27023-00	23-51
27027-00	34-25
27030-02	14A-28
27030-03	14A-28
27032-00	42E-17
27035-07	14A-6
27035-08	14A-6
27035-09	14A-6
27035-10	14A-6
27035-11	14A-6
27046-02	42E-4
27051-00	14A-34
27051-03	14A-34
27053-00	26-2
27053-01	26-2
27055-00	26-5d
27056-00	26-5e
27056-01	26-5e
27059-00	32-38
27064-00	37-46a
27065-00	6-8
27068-00	35-11
27072-02	16A-35
27098-00	Misc.
27099-00	39-11
27100-00	40-27a

Part Number	Fig. and Index
27102-00	33-10
27104-00	31-42
27105-00	31-46
27105-01	31-46
27108-02	11B-25
27108-03	11B-26
27108-04	11B-27
27109-00	11B-32
27110-00	44-9
27111-00	10-23
27111-01	10-23
27112-00	31-44
27113-02	30A-11
27113-03	30A-11
27115-00	11B-23
27116-00	44-11
27118-00	44-8
27123-00	45-4
27124-00	47-38
27127-00	47-40
27129-02	42-50
27130-00	14-31a
27130-00	14-68
27130-00	14A-81
27132-00	14-105
27142-00	25-71
27142-00	26-1
27178-00	14A-82
27183-00	31-32
27183-03	31-33
27196-00	14A-93
27198-00	14-31a
27198-00	14-68
27198-00	14A-81
27200-08	31-45
27207-00	45-59
27207-01	45-59
27212-00	51-74
27214-00	52-91
27214-00	52A-57
27221-00	39-31
27221-00	40-12
27229-00	30-62
27244-00	18B-22
27245-00	18B-22
27245-00	18B-23
27246-02	35B-6
27246-03	35B-6
27247-02	2-39
27247-02	3-1
27247-06	3-18
27247-07	3-16
27249-00	35B-7
27250-00	35B-7
27252-00	18A-53
27254-00	42B-10
27255-00	42B-10a
27256-00	38-53

Part Number	Fig. and Index
27257-00	26-61
27258-00	26-62
27260-02	26-5b
27261-00	41-23
27265-00	14A-35
27268-00	14A-33
27274-00	42B-11
27275-00	11B-21
27276-00	11B-22
27277-03	11B-9
27278-00	11B-16a
27279-00	11B-19
27280-00	8A-37
27283-00	11B-71
27288-00	14A-28
27323-00	12-59
27447-00	35B-15
27528-00	15A-36
27559-00	12-57
27561-00	12-89
28625-05	14A-19
29999-02	29-47
29999-10	15A-73
29999-11	15A-74
30234-00	14-59
30234-00	14A-80
30234-00	42B-47
30234-03	14A-80
30279-00	49-30
30279-00	51-16
30282-00	51-7
30304-00	11-49
30353-18	14A-13
30353-18	Misc.
30353-20	14-3
30353-20	14A-13
30353-20	Misc.
30355-00	16A-45
30405-01	11A-58
30426-06	17-37
30426-06	17A-6
30670-02	19-5
30670-03	19-5
30679-00	19-6
30929-03	37-88
30929-07	37-89
30929-08	37-90
30953-00	56-2
30955-00	56-3
30960-02	56-1
30960-03	56-1
30960-04	56-1
30960-05	56-1
30960-06	56-1
30960-07	56-1
30960-08	56-1
30960-09	56-1
30960-10	56-1

Part Number	Fig. and Index
30960-11	56-1
30960-12	56-1
30960-13	56-1
30960-14	56-1
30960-15	56-1
30960-16	56-1
31045-00	49-18
31045-01	49-18
31109-00	15-59
31186-03	18-48
31186-04	18-48
31186-05	18-48
31186-13	18-48
31186-14	18-48
31186-15	18-48
31190-00	40-27
31196-03	40-24
31196-05	40-24
31322-07	25-27
31391-00	15-59
31391-00	15A-45
31429-00	21-18b
31494-00	11-116
31506-02	35B-10
31506-02	41-60
31506-02	42B-23
31506-02	50-2
31506-02	52-9
31506-02	52A-51
31506-04	35B-11
31506-06	42B-24
31506-06	52-17
31614-00	54-4
31632-00	41-68
31633-00	41-71
31638-00	41-65
31671-00	49-26
31671-00	51-58
31709-00	14-102
31709-00	14A-54
31747-00	37-6
31766-00	26-8
31786-03	24-18
31890-03	51-68
31893-02	41-75
31893-02	51-57
31978-11	23A-26
31978-11	23B-28
31978-11	23C-28
31978-12	23A-27
31978-13	23A-28
31978-14	23A-29
31978-15	23A-30
31978-15	23B-30
31978-15	23B-73
31978-15	23C-31
31978-16	23A-31
31978-17	23A-32

**PIPER PARTS CATALOG**

Part Number	Fig. and Index	Part Number	Fig. and Index	Part Number	Fig. and Index	Part Number	Fig. and Index
31978-18	23A-33	32429-37	18A-11	33237-08	57A-1	43362-00	52-21
31978-19	23A-34	32429-38	18A-11	33237-09	57A-1	43363-00	52-21
31997-00	41-66	32429-39	18A-11	33237-10	57A-1	43364-00	43-41
32005-03	51-54	32429-40	18A-11	33237-11	57A-1	43365-00	52-21
32005-03	52-30	32429-41	18A-11	33237-12	57A-1	43365-00	52A-56
32005-03	52A-29	32510-00	14A-36	33237-13	57A-1	43404-00	23-52
32006-03	51-68	32510-00	52-81	33237-14	57A-1	43580-00	41-47
32007-07	52-31	32550-00	50-12	33963-02	69-73a	43775-00	23-54
32007-07	52A-30	32550-00	52-25	39994-11	16-28	43813-03	18A-51
32008-03	51-57	32553-10	15B-1	39994-11	16-30	43813-04	18A-51
32008-03	52-36	32553-11	15B-2	39994-11	16A-36	43813-05	18A-51
32203-02	50-9	32553-12	15B-8	39994-11	16A-37	43813-06	18A-50
32203-04	52-34	32553-13	15B-11	39998-03	22-8	43813-07	18A-50
32203-04	52A-61	32553-14	15B-14	39998-03	22-32	43813-08	18A-50
32203-06	52-35	32553-15	15B-15	39998-03	22-33	43909-03	52-75
32203-06	52A-32	32553-16	15B-10	39999-11	23-1	43909-04	50-25
32205-00	52-2	32553-17	15B-12	39999-13	30A-1	43909-04	52-77
32207-04	52-44	32553-18	15B-13	40071-00	51-71	43909-04	52A-5
32210-02	52-32	32553-19	15B-17	40071-00	52-3	43909-11	52-75
32210-06	52-32	32553-20	15B-16	40081-00	28-17	43909-11	52A-3
32210-06	52A-26	32553-24	15B-9	40081-00	51-72	43918-00	53-5
32212-03	52-33	32603-03	42B-2	40081-00	52-14	43988-02	46-12
32212-03	52A-31	32658-00	14A-55	40111-00	54-6	44180-00	41-113
32213-00	52-39	32671-09	57-1	41001-00	45-13	44275-02	2-66
32254-00	11B-20	32671-10	57-1	41001-00	47-58	44275-04	2-66
32281-03	14-41	32671-11	57-1	41001-03	45-14	44347-02	15A-5
32281-03	14A-14	32671-12	57-1	41001-03	46-22	44347-10	15A-5
32281-04	14-41	32671-13	57-1	41371-02	44-13	44377-04	52A-16
32281-04	14A-14	32671-14	57-1	41371-03	44-13	44386-00	26-16
32370-02	42B-11	32671-15	57-1	41371-04	44-13	44512-00	18A-53
32370-04	42B-13	32671-16	57-1	41413-38	18A-16	44514-00	18A-52
32370-05	42B-15	32671-17	57-1	41413-38	18A-32	44514-01	18A-52
32370-07	42B-36	32737-02	14A-18	41554-00	42B-43	46348-03	35-13
32370-08	42B-37	32737-04	14A-18	41609-00	15A-15	46348-04	35-13
32370-09	42B-7	32739-00	42D-5	41609-00	15A-17	47732-05	42B-45
32370-10	41-72	32739-02	42D-5	41609-00	15A-54	49997-12	35-1
32370-13	52-16	32745-02	14A-56	41678-00	14A-38	49999-05	37-67
32370-13	52A-44	32763-02	50-11	41678-00	14A-39	49999-06	37-68
32370-15	42B-14	32763-02	52-24	41678-00	14A-40	49999-07	37-69
32370-16	42B-16	32766-00	57-6	41679-00	14A-37	50111-00	18-8
32370-16	42E-18	32884-00	15A-72	41679-00	14A-39	50111-00	18A-18
32370-18	42B-36	32944-03	41-117	41679-00	41-48	50111-00	18A-34
32370-19	42B-37	32951-03	41-117	42034-00	14A-66	50111-00	18B-7
32370-22	35B-8	33034-00	41-67	42038-02	50-12	52586-02	52A-22
32371-02	42B-38	33038-00	42E-3	42038-02	52-25	52588-05	52A-28
32371-02	42B-39	33048-00	42E-16	42149-16	45-54	52624-02	52A-37
32371-03	42B-40	33224-00	57A-2	42536-00	11B-69	52785-02	35B-9
32371-03	42B-41	33227-00	57A-3	42537-00	43-7	52798-02	14A-40
32380-00	18A-23	33229-02	57A-6	42538-00	43-39	52826-05	14A-41
32380-00	18A-39	33229-03	57A-6	42571-09	45-45	54536-02	18A-51
32380-00	18B-10	33232-00	57A-4	42740-00	26-63	54536-06	18A-50
32408-00	55-2	33234-00	57A-11	42891-00	18-23	54800-54	54B-1
32408-02	55-2	33237-02	57A-1	42891-00	37-76	55447-02	37-94
32429-32	18A-11	33237-03	57A-1	42891-00	48-33	60054-14	17-25
32429-33	18A-11	33237-04	57A-1	43086-02	14A-39	60054-17	46-65
32429-34	18A-11	33237-05	57A-1	43255-02	43-2	60054-18	46-15
32429-35	18A-11	33237-06	57A-1	43360-00	52-22	60054-23	41-57
32429-36	18A-11	33237-07	57A-1	43360-00	52A-55	60054-40	20B-43

## PIPER PARTS CATALOG

Part Number	Fig. and Index
61323-09	23-28
61323-12	23-28
61323-13	23-30
61402-24	19-34
61402-29	46-50
61402-32	46-46
61402-34	46-51
61402-35	46-47
61402-36	46-48
61402-39	9-16
61402-43	46-52
61402-44	46-66
61402-51	16A-46
61402-58	25-39
61402-59	25-39
61402-60	19-34
61402-62	28-18
61402-63	28-18
61402-64	37-46
61402-64	37-46a
61402-71	30A-14
61541-16	22-6
61541-17	22-24
61541-18	22-7
61541-19	22-7
61541-20	14-48
61541-20	22-8
61541-21	14-49
61541-23	35-20
61541-25	22-29
61541-27	38-77
61541-28	38-5
61541-39	22-33
61541-48	22-8
61541-49	22-32
62226-00	42C-1
62226-00	42D-3
62227-00	42C-2
62227-00	42D-4
62228-00	42C-3
62342-00	42C-4
62343-00	42C-5
62343-00	42D-5
62355-02	42C-8
62355-02	42D-1
62355-02	Misc
62355-03	42C-9
62355-03	42D-2
63900-54	18B-5
64076-10	17A-37
64076-10	38-56
64076-12	38-58
64076-13	38-57
66980-00	19-67
70371-02	19-43
70371-02	19-70
70371-02	21-38
70371-03	19-44

Part Number	Fig. and Index
70371-03	19-71
70371-03	21-39
70371-03	37-91
80002-76	35-21
80012-04	48-30
80012-06	24-51
80012-11	37-92
80012-77	24-17
80012-94	2-41
80012-94	45-42
80012-95	43-29
80012-95	43-33
80022-74	45-40
80022-87	45-41
80022-92	5-6
80022-96	47-54
80022-97	11-22
80022-97	11A-22
80022-100	37-58
80022-119	30-8
80032-20	37-78
80032-44	21-28
80032-53	23-17
80042-71	41-79
80042-72	41-80
80042-73	41-81
80042-74	41-82
80122-07	13-7
80122-10	28-19
80122-10	45-31
80122-18	48-39
80122-25	45-32
80122-70	46-23
80122-81	14-39
80122-81	14A-69
80122-83	14-40
80122-83	14A-70
80122-86	25-32
80122-89	26-40
80122-91	25-72
80122-99	2-37
80122-119	37-70
80122-120	37-70
80379-02	14-106
80379-02	14A-94
80421-00	46-36
80421-00	47-55
80421-00	48-34
81262-72	31-14
81262-82	29-35
81262-83	37-75
81262-92	24-6
81262-95	29-24
81262-105	38-112
81342-05	2-62
81342-13	42C-15
81342-13	42D-13
81342-18	37-73

Part Number	Fig. and Index
81342-19	19-45
81342-19	19-72
81342-56	41-95
81342-56	42-21
81342-89	43-27
81342-90	43-27
81342-91	43-27
81342-92	43-13
81342-93	43-14
81342-96	45-35
81342-98	47-13
81761-58	16A-44
82371-28	22-27
82371-47	39-20
82371-54	22-11
82371-69	22-10
82371-92	21-31
82371-95	38-87
82732-68	46-33
82732-95	47-56
82732-98	33-12
82732-98	46-55
82732-99	33-11
82732-107	17A-28
83161-03	23-31
83161-17	14A-76
83161-27	23-47
83161-27	42-47
83161-41	23-35
83302-24	23A-58
83302-24	23B-11
83302-24	23C-11
83302-31	29-42
83302-37	46-53
83302-40	25-41
83302-40	46-35
83302-42	29-30
83302-42	46-16
83302-47	17-26
83302-47	17A-25
83302-48	17-27
83302-50	46-20
83302-53	17-41
83302-53	17-42
83302-54	46-76
83302-55	29-42
83302-61	46-14b
83302-65	37-77
83302-66	17A-25
83302-67	17A-26
85012-14	37-74
85012-30	18-10
85012-30	18A-20
85012-30	18A-36
85012-100	29-41
85012-101	35-58
85052-37	19-46
85052-39	19-46

Part Number	Fig. and Index
85512-12	16-37
85512-12	16A-17
85512-13	16-37
85512-14	17-38
85512-20	16A-18
85512-21	16A-19
86062-86	24-47
86062-86	25-40
86062-88	24-18
86062-92	18-3
86062-94	35-22
86062-102	25-81
86092-66	48-6
86092-82	37-82
86102-27	16-30
86102-27	16A-36
86102-56	18-9
86102-56	18A-19
86102-56	18A-35
90797-80	38-67
90797-90	17-43
91193-00	37-83
99479-02	14-103
99479-02	14A-64
180 806	7-31
180 806	36-62
180 807	36-7
180 807	36-16
187 625	26-28
189 302	40-26
400 002	31-6
400 002	31-25
400 002	35-37
400 004	24-35
400 004	25-47
400 004	35-37
400 008	46-73
400 009	24-33
400 014	25-42
400 016	25-73
400 019	25-33
400 055	46-72
400 057	46-70
400 059	48-9
400 105	24-52
400 108	31-12
400 109	24-53
400 218	24-46
400 223	24-45
400 227	24-57
400 368	25-67
400 438	3-5
400 438	26-58

## PIPER PARTS CATALOG

Part Number	Fig. and Index	Part Number	Fig. and Index	Part Number	Fig. and Index	Part Number	Fig. and Index
400 440	2-46	401 922	38-68	404 836	35-37	406 363	31-31
400 440	26-5f	402 310	48-5	404 837	42C-12	406 439	11B-52
400 440	37-80	402 311	48-11	404 837	42D-12	406 660	25-43
400 441	24-52	402 313	26-59	404 838	25-38	406 701	16-4
400 449	48-20	402 316	33-26	404 838	27-11	406 701	16A-3
400 463	35-39	402 321	31-38	404 840	26-41	406 704	14A-66
400 466	29-50	402 325	26-26	404 887	2-45	406 704	14A-67
400 673	46-74	402 344	26-60	404 887	2-46	406 848	54-11
400 675	31-21	402 346	31-39	404 887	12-60	406 870	42C-13
400 675	31-24	402 350	2-62	404 887	24-34	406 870	42C-15
400 675	38-55	402 352	25-75	404 887	24-52	407 041	54-12
400 693	30-61	402 530	24-41	404 887	31-13	407 103	20A-73
400 708	31-17	402 800	26-18	404 887	46-69	407 103	20A-77
400 748	24-40	404 100	31-24	404 888	2-3	407 104	42C-13
400 757	25-58	404 100	46-70	404 888	2-7	407 104	42C-15
400 761	25-84	404 100	46-72	404 888	18B-22	407 128	20B-23
400 939	29-13a	404 100	48-9	404 888	18B-23	407 128	25-80
401 054	25-24	404 101	24-52	404 888	24-33	407 133	20B-7
401 185	42D-12	404 101	24-53	404 888	24-35	407 133	20B-10
401 186	2-23	404 101	26-59	404 888	24-56	407 133	20B-13
401 186	42C-12	404 101	31-12	404 888	25-33	407 133	20B-17
401 187	25-45	404 101	31-17	404 888	25-49	407 134	14A-66
401 188	2-18	404 101	48-5	404 888	25-73	407 134	14A-67
401 189	2-27	404 102	26-60	404 888	26-26	407 134	20A-21
401 189	2-47	404 103	24-31	404 888	27-28	407 134	20A-26
401 263	26-48	404 103	24-32	404 888	27A-14	407 134	20A-29
401 264	26-49	404 103	24-45	404 888	31-6	407 134	20A-34
401 266	24-34	404 103	24-46	404 888	31-8	407 134	20A-38
401 266	31-7	404 103	24-57	404 888	31-9	407 134	20A-52
401 266	38-114	404 105	24-41	404 888	31-25	407 134	20A-63
401 266	48-21	404 224	31-21	404 888	31-38	407 134	20A-91
401 269	26-5g	404 322	17-14	404 888	33-26	407 134	27A-8
401 270	2-4	404 392	47-74	404 888	46-73	407 135	26-58
401 270	31-13	404 394	24-40	404 888	48-11	407 562	17-52
401 270	46-69	404 395	25-58	404 889	2-23	407 562	34-24
401 270	48-8	404 395	25-84	404 889	2-27	407 562	47-57
401 273	46-75	404 398	25-20	404 889	2-47	407 562	48-19
401 311	2-7	404 823	17A-31	404 889	27-28	407 563	20A-35
401 311	24-56	404 823	17A-33	404 889	27A-14	407 564	2-4
401 311	35-36	404 829	25-70	404 889	31-22	407 564	17-51
401 312	2-3	404 829	34-24	404 889	31-26	407 564	26-18
401 315	18B-23	404 833	14A-67	404 889	31-27	407 564	29-48
401 329	26-27c	404 833	25-68	404 889	31-39	407 564	29-50
401 334	27A-12	404 833	25-69	404 889	45-33	407 564	30-48
401 335	27-29	404 835	2-4	404 890	2-18	407 564	31-7
401 346	25-44	404 835	26-5f	404 890	2-42	407 564	31-8
401 359	46-71	404 835	26-5g	404 890	2-44	407 564	31-13
401 382	31-26	404 835	29-50	404 890	2-48	407 564	42C-14
401 384	31-27	404 835	30-49	404 890	2-61	407 564	42D-11
401 393	2-42	404 835	42C-14	404 890	2-62	407 564	42D-13
401 393	2-61	404 835	42D-11	404 890	2-63	407 564	46-69
401 393	2-63	404 835	42D-13	404 890	25-75	407 564	46-74
401 394	2-48	404 835	48-8	404 910	14A-66	407 564	46-75
401 396	2-44	404 835	48-20	404 913	25-67	407 564	48-9
401 410	35-35	404 835	48-21	404 971	17A-34	407 564	48-20
401 550	35-38	404 836	26-27c	404 971	17A-35	407 564	48-21
401 918	38-68	404 836	29-13a	404 973	37-80	407 565	15A-59
401 919	35-40	404 836	35-36	406 362	31-28	407 565	18B-22



# PIPER PARTS CATALOG

Part Number	Fig. and Index
407 565	24-33
407 565	24-35
407 565	24-52
407 565	24-53
407 565	24-56
407 565	25-73
407 565	26-59
407 565	27-30
407 565	27A-13
407 565	29-13a
407 565	31-6
407 565	31-9
407 565	31-12
407 565	31-17
407 565	31-25
407 565	33-26
407 565	35-36
407 565	35-37
407 565	48-5
407 565	48-11
407 566	2-23
407 566	2-27
407 566	2-47
407 566	24-40
407 566	27-30
407 566	27A-13
407 566	31-26
407 566	31-27
407 566	31-39
407 566	37-72
407 566	42C-12
407 566	42D-12
407 567	2-42
407 567	2-44
407 567	2-48
407 567	2-61
407 567	2-63
407 567	24-32
407 567	24-45
407 567	24-46
407 567	24-57
407 567	25-75
407 567	35A-7
407 569	24-41
407 569	31-24
407 570	25-67
407 582	17A-34
407 582	17A-35
407 583	17A-31
407 584	2-45
407 584	2-46
407 584	3-53
407 584	20B-22
407 584	24-34
407 584	24-52
407 584	26-5f
407 584	26-5g
407 584	29-50

Part Number	Fig. and Index
407 584	48-9
407 585	2-3
407 585	2-7
407 585	25-48
407 585	26-26
407 585	26-27c
407 585	26-59
407 585	27-16
407 585	30-41
407 585	30A-34
407 586	2-18
407 586	25-46
407 586	26-60
407 586	31-22
407 587	24-31
407 587	25-58
407 587	25-84
407 587	27-12
407 610	17A-33
407 674	12-60
407 674	17A-32
407 682	37-80
408 816	28-20
408 827	37-71
410 040	15A-75
410 044	18-41
410 046	18-42
410 047	2-45
411 230	31-9
411 231	31-8
411 234	15A-59
411 349	24-2
411 532	12-60
411 532	42D-13
414 722	25-69
414 748	31-28
414 748	31-29
414 763	36-10
414 781	17A-31
414 781	17A-38
414 781	17A-44
414 781	17A-45
415 149	34-24
415 264	16A-8
415 266	16A-7
415 266	16A-8
415 270	16A-7
415 289	32-8
415 292	32-8
415 445	25-80
415 457	25-68
415 495	17A-34
415 497	17A-35
415 520	54-10
415 538	14A-67
415 543	17A-33
415 742	25-70
415 751	20A-25

Part Number	Fig. and Index
415 751	20A-51
415 751	20A-89
415 752	20A-62
415 752	20A-76
415 752	20A-90
415 753	20A-20
415 753	20A-72
415 754	20A-28
415 754	20A-33
415 755	20A-37
415 769	46-21
416 184	31-47
416 794	42C-14
416 794	42D-11
417 563	20A-30
417 715	42C-13
417 715	42C-15
418 419	35-54
418 421	35-55
419 600	24-38
419 600	26-19
419 600	26-64
419 806	2-28
419 806	2-40
419 946	31-30
419 964	38-60
419 991	31-21
424 051	17-51
424 051	17-52
424 051	17A-19
424 051	24-40
424 051	24-52
424 051	24-53
424 051	31-12
424 051	31-17
424 051	31-24
424 051	46-70
424 051	46-72
424 051	46-74
424 051	47-57
424 051	48-5
424 051	48-9
424 051	48-19
424 052	26-59
424 052	26-60
424 059	24-31
424 059	24-32
424 059	24-41
424 059	24-45
424 059	24-46
424 059	24-57
424 059	25-58
424 059	25-84
424 061	35A-27
424 061	35A-34
424 071	25-83
424 144	17-52
424 145	47-57

Part Number	Fig. and Index
424 147	48-19
424 176	17-51
424 176	17-53
424 182	17-28
424 184	17-29
434 127	38-114
434 127	49-21
434 129	20B-41
434 132	23A-11
434 138	23A-10
434 139	20A-23
434 140	21-37
450 035	41-98
450 035	42-27
450 385	41-103
450 386	41-101
450 646	14-2
450 646	14A-15
450 689	14-50
450 706	14A-10
450 739	14-76
450 741	41-9
450 742	41-10
450 788	14-24
450 788	14A-10
450 929	35-2
450 929	35A-1
451 724	24-43
451 735	24-44
451 735	25-52
451 755	24-42
451 755	27A-1
451 779	25-50
451 779	27-22
451 782	25-36
451 784	24-42
451 784	27A-1
451 800	54-1
451 801	54-5
451 854	14-43
451 857	19-53
451 857	52-19
451 857	52A-42
451 862	50-29
451 862	52-80
451 881	52-13
451 900	35-61
451 905	54-14
451 939	14-78
451 939	14A-51
451 939	50-4
451 939	50-29
451 939	52-12
451 939	52-80
451 939	52A-41
452 011	43-16
452 011	45-6
452 011	45-9

# PIPER PARTS CATALOG

Part Number	Fig. and Index
452 011	46-28
452 011	46-77
452 015	45-56
452 019	48-48
452 340	43-26
452 344	45-39
452 344	46-56
452 347	31-16
452 357	24-12
452 358	45-44
452 361	45-37
452 361	46-57
452 362	45-38
452 362	46-58
452 366	26-12
452 369	43-25
452 373	29-16
452 374	47-44
452 374	48-3
452 376	48-15
452 377	29-39
452 383	28-5
452 383	44-3
452 383	47-11
452 383	47-39
452 383	48-2
452 386	188-4
452 410	42-43
452 412	29-38
452 412	46-64
452 575	25-9
452 575	25-13
452 897	41-28
453 124	26-43
453 141	15-32
453 141	15-42
453 141	15-52
453 171	42C-11
453 415	15-55
453 415	16A-34
453 424	14A-73
453 424	52-49
453 616	14-20
453 617	35-34
453 639	25-82
453 641	28-21
453 646	28-10a
453 655	14A-46
453 661	18A-48
453 662	14-57
453 672	38-99
453 681	38-98
453 732	23B-12
453 732	23C-12
453 865	14A-86
454 053	26-44
454 656	35B-12
454 656	40A-32

Part Number	Fig. and Index
454 656	41-43
454 656	42B-26
454 656	42E-15
454 656	50-3
454 656	51-19
454 656	52-10
454 656	52A-45
454 657	41-43
454 657	42B-26
454 658	41-43
454 658	41-73
454 658	42B-26
454 659	41-43
454 659	42B-26
454 661	41-43
454 661	42B-26
454 662	41-43
454 662	41-61
454 664	49-19
454 667	42B-25
454 712	42B-25
454 805	21-21
454 815	35-23
454 818	38-73b
454 832	14-42
454 832	22-21
454 833	23-41
454 833	23B-64
454 833	23C-62
454 848	19-4
454 859	21-24
454 860	19-73
454 864	21-29
454 867	43-17
454 867	45-10
454 867	45-57
454 867	46-29
454 867	46-79
454 868	22-14
454 881	35-44
454 885	19-41
454 887	19-35
454 901	37-23
454 912	21-25
454 922	39-22
454 925	41-93
454 925	42-24
454 933	22-13
454 934	19-41
454 940	22-12
454 943	22-20
454 981	35-23
454 982	15A-43
454 983	21-20
454 983	52-64
454 987	21-34
454 987	22-22
454 987	22-28

Part Number	Fig. and Index
454 997	35-41
455 124	26-42
455 149	40-34
455 151	41-100
455 151	42-23
455 173	23-40
455 174	19-40
455 180	29-36
455 226	56-12
455 227	56-14
455 228	56-12
455 229	56-15
455 256	30-21
455 929	30-22
455 931	30A-19
456 388	54-2
456 728	42C-6
456 728	42D-7
457 860	41-72
458 867	35-32
458 872	19-38
458 873	38-109
458 877	19-58
458 878	38-105
458 879	23-19
458 880	23-20
458 884	38-90
458 891	30-53
458 892	35-33
458 893	14-17
458 893	14A-77
458 893	19-39
458 893	23-38
458 894	30A-15
458 894	30A-20
458 896	40A-34
458 900	30-18
458 901	38-95
458 901	40A-6
458 910	23-24
458 910	30A-16
458 911	38-106
458 914	22-25
458 929	14-18
458 929	51-18
458 933	38-94
458 937	19-61
458 937	23-22
458 938	23-23
458 939	38-96
458 940	38-97
458 945	14-19
458 948	14-18
458 948	14-19
458 948	50-6
458 958	22-15
459 928	43-34
459 930	43-30

Part Number	Fig. and Index
459 930	43-35
459 958	45-55
460 027	17-35
460 027	17A-5
460 630	35-24
460 685	23-27
460 687	25-19a
460 690	26-3
460 690	26-6a
460 690	26-24
460 691	25-10
460 691	25-14
460 691	25-16
460 691	25-63
460 691	26-6a
460 691	26-7
460 691	26-54
460 783	54-9
460 860	25-62b
460 888	22-30
460 901	41-27
461 133	46-78
461 136	45-7
461 623	41-42
461 623	41-51
462 006	21-16a
462 006	21-17a
462 012	41-31
462 014	39-21
462 014	40-13
462 018	41-33
462 021	40-4
462 034	26-32
462 044	41-32
462 046	41-30
462 058	19-60
462 058	40A-41
462 059	38-101
462 059	38-107
462 060	38-102
463 391	8-28
463 391	8A-29
463 400	36-60
463 600	42B-29
464 022	17-49
464 023	48-23
464 031	17-49
464 346	19-47
464 346	20-1
464 362	Misc.
465 162	41-34
465 256	41-41
468 002	42B-34
468 006	42B-34
468 007	41-69
468 008	41-70
469 132	47-22
469 132	47-35

## PIPER PARTS CATALOG

Part Number	Fig. and Index
469 132	47-53
469 138	28-2
471 056	29-4
471 059	15A-19
471 059	15A-28
471 064	37-3
471 068	42A-9
471 075	15-34
471 075	15-44
471 075	15-54
471 077	15-38
471 077	15-48
471 091	17-47
471 092	17-47
471 093	18A-27
471 093	18A-42
472 026	15-66
472 026	15A-62
472 028	42B-50
472 028	48-46
472 036	15-65
472 037	14-63
472 037	14-74
472 037	14-84
472 037	14A-85
472 038	15-67
472 038	15A-63
472 050	41-105
472 054	14A-9
472 054	42A-22
472 054	42B-19
472 054	48-46
472 054	53-6
472 064	57A-5
472 332	42A-23
472 332	42B-20
472 333	42A-23
472 333	42B-20
472 334	42A-23
472 338	42B-20
472 653	14A-48
472 661	42-40
472 665	2-56
472 665	42-31
472 666	2-53
472 666	42-34
472 684	43-31
472 694	42A-26
472 694	42B-44
472 736	33-22
472 736	42-37
472 741	42B-27
472 770	41-108
472 770	52-72
472 770	52-85
472 776	14A-43
472 816	14A-83
472 862	42B-49

Part Number	Fig. and Index
474 055	23A-19
474 055	23B-21
474 055	23C-21
474 085	23A-19
474 085	23B-21
474 085	23C-21
474 087	23A-19
474 087	23B-21
474 087	23C-21
474 111	23A-19
474 111	23B-21
474 111	23C-21
474 345	43-2a
474 647	Misc.
474 654	Misc.
475 109	14A-66
475 116	35-26
475 117	35-26
475 126	14-15
475 130	51-20
475 130	52-15
475 192	46-19
476 647	14A-53
476 647	23-44
476 649	23-43
476 661	40A-34
476 673	42C-7
476 678	50-4
476 678	52-12
476 678	52A-60
476 684	35-31
476 686	19-54
476 700	40A-42
477 614	40A-33
477 617	19-63
477 618	30-20
477 618	30A-18
477 620	40A-8
477 621	22-26
477 628	19-62
477 629	19-59
477 629	20A-44
479 445	23A-19
479 445	23B-21
479 445	23C-21
480 682	48-37
480 683	17-31
480 683	18-16
480 687	26-19
480 688	16A-40
480 690	18B-14
480 697	37-61
480 700	24-37
480 701	18-15
480 701	18A-25
480 701	18A-41
480 701	18B-12
480 705	47-59

Part Number	Fig. and Index
480 706	17-30
480 706	48-45
480 707	48-37
480 727	18B-13
480 733	17A-29
480 734	17A-30
480 997	54-14
481 002	54-15
481 214	42E-1
481 621	45-16
481 621	48-22
481 623	46-43
481 640	45-53
481 640	45-60
481 640	52-3
481 683	22-18
481 692	22-18
484 183	41-102
484 193	57A-10
484 214	57A-9
484 254	41-118
484 278	14A-8
484 308	48-47
484 310	36-26a
484 322	7-24
484 322	36-26a
484 326	14-64
484 326	14-75
484 326	14-85
484 327	14-65
484 327	14-75
484 327	14-86
484 342	13-14
484 342	39-6
484 342	40-33
484 348	14-104
484 348	14A-79
484 350	40A-40
484 352	38-100
484 372	56-8
484 373	42C-10
484 373	42D-6
484 380	41-26
484 380	42B-4
484 385	15-33
484 385	15-43
484 385	15-53
484 388	56-10
484 410	56-11
484 411	42A-4
484 443	42B-5
484 464	15A-76
484 482	7-30
484 482	7-39
484 482	36-24
484 575	15A-65
484 582	42A-3
484 583	42A-3

Part Number	Fig. and Index
484 585	57-4
484 585	57A-7
484 698	27-5
484 700	30-45
484 701	27-21
484 701	30-30
484 701	30A-24
484 706	30-31
484 706	30A-25
484 707	39-11a
484 707	40-28
484 708	39-11b
484 708	40-29
484 711	26-23
484 712	26-38
484 714	26-39
484 717	26-15
484 718	26-30
484 719	25-8
484 719	25-12
484 723	26-39
484 734	26-31
484 744	23-33
484 755	36-61
484 826	26-47
486 425	41-30
486 562	54-8
486 583	14-47
486 583	14A-68
486 627	35B-2
486 879	54-7
486 899	40A-13
487 149	41-99
487 149	42-1
487 152	41-11
487 152	42-6
487 154	46-12
487 163	41-99
487 291	45-52
487 291	46-67
487 350	14-46
487 350	14A-72
487 428	35-59
487 545	14-11
487 570	14-45
487 590	39-9
487 590	40-30
487 594	14-44
487 608	49-22
487 624	55-5
487 629	15-15
487 654	41-29
487 657	40-30
487 657	51-14
487 659	36-22
487 660	7-25
487 661	7-35
487 661	7-36

## PIPER PARTS CATALOG

Part Number	Fig. and Index
487 665	21-23
487 666	21-22
487 668	13-13
487 668	13-19
487 668	13-29
487 669	36-23
487 670	7-37
487 671	7-38
487 684	36-58
487 689	36-59
487 692	39-9
487 726	14A-71
487 747	13-29
487 777	15-68
487 777	15A-64
487 790	35B-8
487 790	42A-11
487 790	42A-12
487 790	42A-13
487 790	42A-14
487 790	42A-15
487 790	42A-16
487 803	42A-10
487 804	37-59
487 804	41-106
487 804	41-112
487 805	42-7
487 805	46-24
487 820	41-52
487 820	41-53
487 820	42-8
487 820	42-29
487 828	42A-18
487 828	42A-25
487 839	42A-20
487 839	42B-30
487 845	42A-19
487 846	56-5
487 847	56-6
487 848	56-4
487 852	42B-12
487 858	42A-21
487 859	41-76
487 859	51-57a
487 860	42A-28
487 860	52-16
487 861	52-40
487 861	52-71
487 862	41-53
487 863	42-8
487 863	42-49
487 864	42-49
487 865	42A-19
487 865	42B-31
487 873	51-57a
487 873	52-37
487 873	52-70
487 876	56-5

Part Number	Fig. and Index
487 878	41-104
487 904	43-42
487 904	52-83
487 904	52A-54
487 905	14-97
487 905	23-50
487 940	20B-42
487 940	37-60
487 940	41-112
487 957	42B-28
487 998	42B-42
488 310	14-52
488 310	14A-52
488 310	14A-74
488 310	23-39
488 310	52-67
488 310	52A-43
488 311	30A-17
488 321	38-91
488 327	37-84
488 383	30-19
488 474	23-45
488 481	38-103
488 486	41-55
488 525	23-48
489 372	56-7
489 390	15A-15
489 390	15A-17
491 048	38-88
491 049	23-25
491 050	27-20
491 050	30-16
491 051	38-89
491 051	38-104
491 052	40A-7
491 055	23-18
491 058	38-93
491 059	19-64
491 059	23-21
491 060	30-17
491 064	38-92
491 067	19-61
492 066	22-17
492 079	22-19
492 082	21-16a
492 082	21-17a
492 100	23-37
492 136	38-61
492 137	38-61
494 004	17A-38
494 004	17A-44
494 055	42A-27
494 060	13-12
494 060	13-18
494 060	13-28
494 060	39-10
494 060	40-31
494 060	51-13

Part Number	Fig. and Index
494 063	40-5
494 071	2-28
494 071	2-40
494 071	31-28
494 071	31-29
494 082	37-55
494 087	42C-14
494 087	42D-11
494 159	42-51
494 159	51-55b
494 678	54-3
502 342	31-22
550 380	41-102
550 383	41-103
550 393	41-103
550 559	52-58
550 559	52A-20
550 606	14-51
550 606	14A-78
550 625	51-47
550 626	49-11
550 626	51-48
550 640	49-11
550 641	51-47
550 642	49-12
550 643	49-11
550 643	51-48
550 644	49-11
550 644	51-48
550 645	49-12
550 646	14-23
550 647	14-21
550 684	14-22
550 684	14A-17
550 758	Misc.
550 776	51-47
550 777	49-12
550 778	49-11
550 778	50-20
550 778	51-48
550 778	52-57
550 778	52A-19
550 779	49-11
550 779	51-48
550 782	14-24
550 804	14A-27
550 911	35-25
550 911	35A-1
550 915	35-25
550 915	35A-1
550 916	35-25
550 916	35A-1
550 929	35A-1
550 930	35A-1
551 114	50-13
551 114	52-26
551 114	52A-23
551 131	51-37

Part Number	Fig. and Index
551 215	Misc.
551 216	55-1
551 229	Misc.
551 233	55-2
551 702	25-53
551 702	27-1
551 752	25-50
551 752	27-22
554 731	35B-14
554 757	17-50
554 757	37-23
554 802	22-23
554 803	35-42
554 804	35-43
554 834	35B-13
554 888	38-113
558 901	22-16
558 913	14-79
558 913	50-5
558 936	14A-50
558 937	14A-49
558 937	50-5
558 937	50-7
558 937	52-13
558 937	52-18
558 937	52A-40
565 273	41-34
565 288	42A-29
565 288	42B-32
565 325	41-34
565 446	15A-6
571 098	41-58
571 100	15A-77
571 105	37-3
571 109	18A-27
571 109	18A-42
571 112	42B-1
571 112	42B-33
571 112	52-47
571 113	19-68
571 114	41-58
571 114	57-5
571 127	57A-8
571 131	18B-17
581 043	54-9
581 126	42-52
581 126	51-55c
581 623	34-26
581 623	42E-7
581 700	35-63
581 753	54-14
587 600	18A-27a
587 600	18A-42a
587 863	42B-48
587 867	57A-12
587 868	57A-13
587 869	57A-14
587 899	42B-28

# PIPER PARTS CATALOG

Part Number	Fig. and Index
588 378	45-8
596 058	41-119
596 071	57-2
596 072	57-3
596 333	Misc.
597 257	54B-6
751 201	2-55
751 201	42-36
751 202	2-58
751 202	42-33
751 203	33-23
751 203	42-39
751 228	4-67
751 228	5-51
751 231	20-15
751 235	20-9
751 239	51-41
751 240	51-31
751 257	20A-50
751 258	20A-3
751 259	20B-5
751 262	49-5
751 263	51-41
751 272	49-32
751 272	51-73
751 276	51-55a
751 276	52-79a
751 277	51-53a
751 278	52-51
751 283	50-17
751 284	52-52
751 291	14-101
751 291	14A-63
751 294	14A-89
751 300	53-1
751 301	52-79b
751 301	52A-2
751 314	52A-7
751 316	54A-3
751 318	54A-4
751 319	54A-5
751 381	42-32
751 381	42-35
751 381	2-54
751 381	2-57
751 397	20-21
751 402	27-10
751 405	27A-12
751 412	49-23
751 412	51-51
751 426	35A-15
751 431	20-16
751 432	20-34
751 445	30-46
751 446	30-50
751 460	51-22
751 461	51-23
751 468	27-15

Part Number	Fig. and Index
751 489	27-31
751 489	27A-6
751 494	27-24
751 494	27-26
751 494	27A-3
751 494	27A-5
751 545	20-36
751 546	20-32
751 547	20-48
751 548	20-3
751 548	20-14
751 550	20-40
751 573	30-23
751 767	39-18
751 772	27-33
751 772	27-34c
751 775	20-13
751 776	20-18
751 781	20-12
751 782	20-30
751 796	38-65
751 798	38-62b
751 801	20A-24
751 802	20A-74
751 803	20B-8
751 810	27-33
751 811	23A-55
751 811	23B-57
751 811	23C-55
751 812	23A-56
751 812	23B-58
751 812	23C-56
751 813	23A-35
751 813	23B-60
751 813	23C-58
751 814	23A-36
751 814	23B-61
751 814	23C-59
751 815	22-17a
751 819	27A-9
751 820	35A-10
751 832	20-49
751 834	26-45
751 849	20-27
751 850	20-38
751 851	20-29
751 852	20-8
751 853	20-43
751 854	20-39
751 859	22-18b
751 871	38-63
751 874	20A-31
751 875	20A-58
751 876	20A-82
751 877	20A-85
751 878	20B-18
751 884	40A-2
751 885	40A-3

Part Number	Fig. and Index
751 896	23B-14
751 896	23C-14
751 913	23A-12
751 913	23B-14
751 914	14-87
751 914	14A-56
751 933	20-19
751 934	20-17
751 952	51-45
751 954	49-8
751 959	19-47
751 959	20A-1
751 960	20A-59
751 961	20B-15
751 962	20B-39
751 980	35A-2
751 987	50-16
751 989	52-42
751 993	52-43
751 996	52-44
752 010	53-2
752 011	53-3
752 016	39-19a
752 016	40-8a
752 044	20-50
752 094	27-4
752 107	20A-39
752 108	20A-18
752 109	20B-2
752 119	14-87
752 122	23A-22
752 122	23B-24
752 122	23C-24
752 126	20-51
752 127	20A-84
752 190	51-30
752 313	20-26
752 315	20-25
752 317	52A-11
752 333	49-4
752 334	51-36
752 335	27-7
752 336	27-9
752 341	20B-31
752 344	40A-28
752 345	40A-29
752 346	40A-25
752 355	23A-13
752 355	23B-15
752 355	23C-15
752 367	20B-31
752 371	53-4
752 374	40A-37
752 416	20-22
752 417	20-20
752 482	24-48
752 483	26-41
752 490	30-42

Part Number	Fig. and Index
752 490	30A-35
752 491	30-26
752 498	20A-83
752 504	23A-54
752 504	23B-56
752 504	23C-54
752 505	23A-57
752 505	23B-59
752 505	23C-57
752 510	35A-6
752 510	35A-43
752 511	35A-8
752 512	35A-14
752 515	35A-43
752 583	23A-16
752 583	23B-18
752 583	23C-18
752 713	35A-21
752 741	38-73
752 746	30-35
752 746	30A-29
752 772	20-31
752 773	20-28
752 791	30-43
752 824	20-33
752 829	27-3
752 829	27-3
752 829	27-34b
752 830	27-34
752 830	27A-11
752 833	20-44
752 839	20-6
752 840	20-52
752 847	30-27
752 847	30A-21
752 848	30-28
752 848	30A-22
752 855	30-39
752 855	30A-32
752 882	27A-7
752 965	27-18
752 971	20-35
752 974	20-47
753 005	20-10
753 006	20-37
753 035	51-42
753 036	49-10
753 036	51-44
753 048	20A-86
753 049	20A-36
753 050	20B-36
753 069	40A-1
753 070	40A-1
753 071	40A-30
753 072	40A-31
753 074	23A-21
753 074	23B-7
753 074	23C-7

# PIPER PARTS CATALOG

Part Number	Fig. and Index
753 081	23B-71
753 081	23C-64
753 110	30-54
753 116	20-2
753 121	20A-81
753 122	20B-37
753 123	20-42
753 128	27A-4
753 129	27A-2
753 168	20-5
753 169	20-23
753 171	30-25
753 172	26-51
753 191	27-23
753 192	27-25
753 194	27-25
753 194	27A-4
753 195	27-23
753 195	27A-2
753 199	20A-56
753 200	20A-45
753 201	20A-60
753 202	20B-19
753 213	14-93
753 213	14A-62
753 381	30-36
753 381	30A-30
753 389	20A-71
753 389	20A-70
753 390	20A-42
753 391	20A-68
753 391	20B-26
753 392	20A-67
753 392	20B-27
753 431	33-24
753 431	42-38
753 433	23A-14
753 433	23B-16
753 433	23C-16
753 435	23A-42
753 437	23A-23
753 437	23B-55
753 437	23C-53
753 457	38-72
753 458	38-72
753 461	35A-3
753 462	35A-4
753 463	35A-17
753 464	35A-25
753 465	35A-25
753 466	35A-31
753 467	35A-30
753 472	40A-25a
753 473	27-29
753 495	35A-39
753 496	50-19a
753 496	52-56a
753 496	52A-13

Part Number	Fig. and Index
753 633	51-39
753 634	49-1
753 634	51-34
753 651	38-69a
753 662	20A-49
753 663	20A-66
753 663	20B-25
753 664	20B-3
753 678	51-39
753 692	Misc.
753 693	51-55
753 693	52-79
753 715	38-69a
753 721	50-25
753 721	52-75
753 721	52-77
753 743	23A-19
753 743	23B-21
753 743	23C-21
753 827	30-38
753 827	30A-36
753 828	30-44
753 841	51-46
753 843	51-40
753 850	27-19
753 868	51-21
753 870	49-2
753 872	51-35
753 873	51-50
753 874	27-2
753 877	49-5
753 880	49-25
753 899	20A-61
753 899	20B-11
753 900	20A-75
753 901	20A-79
753 902	20B-4
753 903	20B-33
753 904	20B-40
753 905	20B-1
753 910	22-18a
753 916	51-41a
753 925	40A-22
753 926	40A-27
753 932	49-27
753 932	51-59
753 938	23A-15
753 938	23B-17
753 938	23C-17
753 941	23A-25
753 941	23B-27
753 941	23C-27
753 942	23A-40
753 942	23B-41
753 942	23C-67
753 943	23A-43
753 943	23B-44
753 943	23C-45

Part Number	Fig. and Index
753 944	23A-49
753 944	23B-50
753 944	23C-49
753 945	23A-51
753 945	23B-52
753 945	23C-51
753 947	23A-45
753 947	23B-47
753 947	23C-48
753 948	14-90
753 948	14A-59
753 949	14-91
753 949	14A-60
753 974	23A-20
753 974	23B-22
753 974	23C-22
753 975	23A-20
753 975	23B-22
753 975	23C-22
753 981	50-15
753 981	52-48
753 981	52A-58
753 982	35A-29
754 232	Misc.
754 321	Misc.
754 364	51-32
754 365	51-33
754 366	49-6
754 366	51-24
754 368	51-25
754 369	51-27
754 370	51-26
754 435	Misc.
754 531	27-27
754 540	40A-19
754 541	40A-20
754 543	40A-4
754 547	23A-18
754 547	23B-20
754 547	23C-20
754 554	27-27
754 707	20-41
754 708	20-7
754 710	20-4
754 758	20A-40
754 761	23A-48
754 761	23B-36
754 761	23B-49
754 762	23A-53
754 762	23B-54
754 769	23B-13
754 769	23C-13
754 771	20A-40
754 807	50-23
754 807	52-59
754 807	52A-18
754 817	23-53
754 826	35A-10

Part Number	Fig. and Index
755 042	42E-5
755 075	42E-14
755 076	42E-13
755 200	42E-6
755 202	52-90
755 202	52A-25
755 224	35A-2
755 427	14-21
755 427	14A-12
755 428	14-23
755 428	14A-11
755 444	50-21
755 499	14-35
755 499	14A-20
755 800	35A-11
755 810	30-29
755 810	30A-23
755 814	51-28
755 825	49-16
755 825	51-52
755 833	51-43
755 838	27-3
755 839	27-6
755 840	27-8
755 857	30-33
755 857	30A-27
755 858	30-34
755 858	30A-28
755 864	20A-80
755 865	20A-78
755 866	20B-20
755 897	40A-23
755 898	40A-24
755 919	38-64
755 929	27-32
755 930	27-34a
755 931	35A-38
755 932	35A-23
755 933	35A-22
755 934	35A-18
755 935	35A-28
755 946	23A-38
755 946	23B-39
755 946	23C-41
755 964	27A-10
755 968	35A-16
755 972	35A-26
755 977	35A-41
755 989	35A-20
755 990	52-50
755 990	52A-17
756 037	42E-10
756 038	23A-43a
756 038	23B-44a
756 038	23C-45a
756 040	35A-44
756 041	35A-45
756 052	52-51a

REVISED: SEPTEMBER 1982

# PIPER PARTS CATALOG

Part Number	Fig. and Index
756 100	20-24
756 102	20-53
756 116	30-24
756 117	30-37
756 117	30A-31
756 118	30-40
756 118	30A-33
756 119	30-47
756 120	30-51
756 121	30-52
756 125	51-38
756 129	27A-8
756 146	51-29
756 147	27-13
756 148	27-14
756 149	27-17
756 151	20-11
756 153	20-45
756 154	20-46
756 155	38-70
756 156	38-71
756 177	20A-27
756 178	20A-32
756 179	20A-41
756 180	20A-22
756 181	20A-53
756 182	20A-54
756 183	20A-43
756 184	20B-24
756 185	20B-30
756 187	20B-38
756 197	20-54
756 198	51-53
756 224	40A-21
756 225	40A-26
756 226	40A-26
756 227	40A-35
756 228	40A-15
756 229	40A-16
756 230	40A-17
756 231	40A-18
756 240	20B-34
756 242	35A-33
756 248	51-53
756 248	52-74
756 248	52A-15
756 255	51-53
756 256	14-92
756 256	14A-61
756 257	49-33
756 262	20B-34
756 273	14A-90
756 274	14A-90
756 284	35A-5
756 285	35A-12
756 286	35A-35
756 287	35A-35
756 293	35A-24

Part Number	Fig. and Index
756 300	23A-37
756 300	23B-38
756 300	23C-40
756 301	23A-46
756 301	23B-72
756 302	23A-47
756 302	23B-37
756 302	23B-48
756 302	23C-39
756 303	23A-50
756 303	23B-51
756 303	23C-50
756 304	23A-52
756 304	23B-53
756 304	23C-52
756 307	14-89
756 307	14A-58
756 319	23A-21
756 319	23B-23
756 319	23C-23
756 337	14A-87
756 347	52-89
756 347	52A-21
756 398	54A-1
756 504	23A-39
756 504	23B-40
756 504	23C-42
756 505	23A-44
756 505	23B-46
756 505	23C-47
756 507	23A-43b
756 507	23B-45
756 507	23C-46
756 510	35A-9
756 519	40A-35
756 577	20A-19
756 602	35A-13
756 607	35A-40
756 609	27-30a
756 618	30-32
756 618	30A-26
756 623	14A-62
756 706	51-49
756 716	49-3
756 720	49-7
756 729	Misc.
756 730	Misc.
756 731	Misc.
756 732	Misc.
756 733	Misc.
756 734	Misc.
756 735	Misc.
756 736	Misc.
756 737	49-24
756 739	Misc.
756 747	Misc.
756 751	Misc.
756 754	Misc.

Part Number	Fig. and Index
756 771	Misc.
756 781	Misc.
756 784	Misc.
756 826	Misc.
756 828	Misc.
756 830	Misc.
756 843	Misc.
756 845	Misc.
756 846	Misc.
756 853	Misc.
756 873	49-31
756 873	51-67
756 879	Misc.
756 901	Misc.
756 907	14-88
756 907	14A-57
756 909	Misc.
756 924	Misc.
756 925	Misc.
756 943	Misc.
756 966	Misc.
756 967	Misc.
756 968	Misc.
756 969	Misc.
756 970	Misc.
756 971	Misc.
756 976	Misc.
756 978	Misc.
756 980	Misc.
756 983	Misc.
756 985	Misc.
757 048	Misc.
757 051	52-55
757 051	52A-10
757 052	50-14
757 052	50-18
757 052	52-27
757 052	52-46
757 052	52-54
757 052	52A-9
757 052	52A-24
757 054	Misc.
757 064	Misc.
757 069	Misc.
757 074	Misc.
757 100	Misc.
757 112	Misc.
757 187	38-62
757 204	40A-5
757 213	23A-17
757 213	23B-19
757 213	23C-19
757 249	35A-19
757 250	35A-36
757 25	35A-32
757 253	35A-37
757 296	52-45
757 297	52-45

Part Number	Fig. and Index
757 321	35A-36
757 375	35B-4
757 382	52A-14
757 538	52-87
757 573	20B-30
757 575	19-36a
757 579	50-26
757 579	52-76
757 579	52-78
757 579	52A-4
757 579	52A-6
757 581	50-19
757 581	52-56
757 590	52-79
757 645	35A-42
757 646	35A-48
757 647	35A-47
757 687	35B-3
757 711	52A-1
757 717	38-71
757 756	20A-41
757 762	42E-2
757 807	52-53
757 810	23A-24
757 810	23B-26
757 810	23C-26
757 826	23B-26
757 826	23C-43
757 833	29-21
757 833	46-18
757 863	45-58
757 866	14A-88
757 877	14A-43a
757 899	22-31
757 905	52-26
757 938	14A-84
757 946	35B-5
757 970	20A-40a
757 982	20A-19a
757 987	20A-40a
758 110	23B-43
758 110	23C-44
758 127	20B-33
758 164	52-56a
758 178	35A-39
758 179	52-56b
758 179	52A-12
758 198	35A-39
758 199	35A-39
758 204	35A-25
758 207	52A-11
758 266	54A-6
758 267	54A-7
758 281	54A-2
758 402	42-44
758 422	35A-25
758 452	54B-2
758 453	54B-2

## PIPER PARTS CATALOG

Part Number	Fig. and Index
760 245	Misc.
760 255	Misc.
760 256	Misc.
760 257	Misc.
760 258	Misc.
760 259	Misc.
760 263	Misc.
760 265	Misc.
760 266	Misc.
760 267	Misc.
760 268	Misc.
760 269	Misc.
760 270	Misc.
760 271	Misc.
760 273	Misc.
760 309	Misc.
760 335	35-19
760 439	Misc.
760 440	Misc.
760 445	Misc.
760 454	35A-46
760 503	16-27
760 503	16A-35
760 522	20A-87
760 590	Misc.
760 592	Misc.
760 621	Misc.
760 622	Misc.
760 627	Misc.
760 644	Misc.
760 744	Misc.
760 844	Misc.
760 845	Misc.
760 846	Misc.
760 914	3-41
761 039	41-111
761 039	52-84
761 039	52A-53
761 077	8-27
761 077	8A-30
761 082	Misc.
761 151	40A-38
761 152	40A-39
761 153	40A-39
761 156	42E-11
761 157	42E-12
761 158	42E-9
761 159	42E-9
761 677	38-69a
761 939	54A-1
761 972	24-43
761 972	25-51
761 995	24-43
761 995	25-51
761 033	24-43
762 033	25-51
762 357	54B-3
762 418	42A-17

Part Number	Fig. and Index
762 451	20A-65
762 451	20B-14
762 452	20A-71
763 019	54B-4
763 469	42E-8
763 526	41-32
763 819	38-69
764 431	14-34
764 432	14A-21
765 003	14-36
765 003	14A-22
765 005	14-37
765 005	14A-23
765 006	14-38
765 006	14A-24

Part Number	Fig. and Index
-------------	----------------

Part Number	Fig. and Index
-------------	----------------



2E6 THRU 2L24  
INTENTIONALLY LEFT BLANK